

SECTION III
POWER SYSTEM PROTECTION

Introduction to Protective Relaying

About Protective Relaying — Faults : Causes and Effects — Protective zones — Primary and Back-up Protection — Back-up Protection methods — Desirable qualities of Protective Relaying — Selectivity and Discrimination — Relay time and fault clearing time — Sensitivity — Stability — Reliability — Adequateness — Terms and Definitions in Protective Relaying — Historical Review — Role of Engineer — About further text — Summary — Questions.

25.1. ABOUT PROTECTIVE RELAYING

Protective relaying is necessary with almost every electrical plant, and no part of the power system is left unprotected. The choice of protection depends upon several aspects such as type and rating of the protected equipment, its importance, location, probable abnormal conditions, cost, etc. Between generators and the final load points, there are several electrical equipment and machines of various ratings. Each needs certain adequate protection.

The protective relaying senses the abnormal conditions in a part of the power system and gives an alarm or isolates that part from the healthy system.

The relays are compact, self-contained devices which respond to abnormal condition. The relays distinguish between normal and abnormal condition. Whenever an abnormal condition develops, the relays close its contacts. Thereby the trip circuit of the circuit-breaker is closed. Current from the battery supply flows in the trip-coil of the circuit-breaker and the circuit breaker opens and the faulty part is disconnected from the supply. The entire process, 'occurrence of fault-operation of relay-opening of circuit-breaker — removal of faulty part from the system', — is automatic and fast. Circuit-breakers are switching devices which can interrupt normal currents and fault currents. Besides relays and circuit-breakers there are several other important components in the protective relaying scheme, these include : protective current transformers and voltage transformers, protective relays, time-delay relays, auxiliary relays, secondary circuits, trip circuits, auxiliaries and accessories, etc. Each component is important. Protective relaying is a teamwork of these components.

The functions of protective relaying include the following :

- To sound an alarm or to close the trip circuit of circuit-breaker so as to disconnect a component during an abnormal condition in the component, which include over-load, under-voltage, temperature rise, unbalanced load, reverse power, under-frequency, short circuits, etc.
- To disconnect the abnormally operating part so as to prevent the subsequent faults, *e.g.* over-load protection of a machine protects the machine and prevents insulation failure.
- To disconnect the faulty part quickly so as to minimize the damage to the faulty part, *e.g.* If a machine is disconnected immediately after a winding fault, only a few coils may need replacement. If the fault is sustained, entire winding may get damaged and the machine may be beyond repairs.
- To localise the effect of fault by disconnecting the faulty part, from the healthy part, causing least disturbance to the healthy system.
- To disconnect the faulty part quickly so as to improve the system stability, service continuity and system performance. Transient stability can be improved by means of improved protective relaying.

Faults cannot be avoided completely. They can be minimized. Protective relaying plays an important role in minimizing the faults, and also in minimizing the damage in the event of faults.

25.2. FAULTS, CAUSES AND EFFECTS*

A fault in its electrical equipment is defined as a defect in its electrical circuit due to which the flow of current is diverted from the intended path. Faults are caused by breaking of conductors or failure of insulation. Fault impedance is generally low, and fault currents are generally high. During the faults, the voltages of the three phases become unbalanced and the supply to the neighbouring circuits is affected. Fault currents being excessive, they can damage not only the faulty equipment, but also the installation through which the fault current is fed. For example, if a fault occurs in a motor, the motor winding is likely to get damaged. Further, if the motor is not disconnected quickly enough the excessive fault currents can cause damage to the starting equipment, supply connections, etc.

Faults in certain important equipment can affect the stability of the power system. For example, a fault in the bus-zone of a power station can cause tripping of all the generator units in power station and can affect the stability of the interconnected system.

There are several causes of faults occurring in a particular electrical plant. Faults can be minimized by improved system design, improved quality of components, better and adequate protective relaying, better operation and maintenance, etc. However, the faults cannot be entirely eliminated. Fault statistics are systematic records regarding number and causes of faults occurring in a particular system. Table 25.1 gives data about such records. These records are useful guides to manufacturers and electricity boards for taking corrective measures.

Faults can be minimized to some extent by taking the following measures :

1. Improvement in the quality of machines, equipment, installation, etc. by improvement in design, manufacturing techniques, materials, quality control, adequate testing, research and development.

2. Improvement in system design, correct lay-out, choice of equipment.

3. Adequate and reliable protection systems ; control.

4. Regular and detailed maintenance by trained personnel.

5. Trained personnel for operation and management of electrical plant.

Table 25.1. Faults in a System in a Year

Equipment	Cause of fault	% of Total Faults
1. Overhead lines	1. Lightning strokes 2. Storms, earthquakes, icing 3. Birds, trees, kites aeroplanes, snakes, etc. 4. Internal over-voltages.	30—40
2. Underground cables	1. Damage during digging 2. Insulation failure due to temperature rise 3. Failure of joints	8—10
3. Alternators (Generator)	1. Stator faults 2. Rotor faults 3. Abnormal conditions 4. Faults in associated equipment 5. Faults in protective system	6—8
4. Transformers	1. Insulation failure (Re. Sec. 12.4) 2. Faults in tap-changer 3. Faults in bushing 4. Faults in protection circuit 5. Inadequate protection 6. Overloading, Over voltage.	10—12

* Ref. Sec. 1.3 and 12.4 for types and causes of faults.

Equipment	Cause of fault	% of Total Faults
5. CT, PT	1. Over-voltages 2. Insulation failures 3. Breaking of conductors 4. Wrong connections.	15—20
6. Switchgear	1. Insulation failure 2. Mechanical defect 3. Leakage of air/oil/gas 4. Inadequate rating 5. Lack of maintenance.	10—12

25.3. IMPORTANCE OF PROTECTIVE RELAYING

Inadequate protection can lead to a major fault that could have been avoided, e.g. the thermal over-load protection of motor prevents the over-loading of motor and thereby the insulation failure is avoided. A damaged equipment needs time for repairs and replacement. By adequate protection, the damage can be eliminated or minimized.

A fault in the equipment in the supply system leads to disconnection of supply to a large portion of the system. If the faulty part is quickly disconnected, the damage caused by the fault is minimum and the faulty part can be repaired quickly and the service can be restored without further delay. Better service continuity has its own merits. Thus the protective relaying helps in improving service continuity and its importance is self-evident.

25.4. PROTECTIVE ZONES

The protective relaying of a power system is planned along with the system design. The circuit-breakers are located at appropriate point such that any component of the power system can be disconnected for usual operation and maintenance requirements, and also during abnormal conditions such as short circuits.

Depending upon the rating of the machine, its location, relative importance, probability of faults and abnormal conditions, etc., each power system component (generator, transformer, transmission lines, bus-bar, cables, capacitors, individual loads, etc.) is covered by a protective zone. A part of the system protected by a certain protective scheme is called protective zone or zone of protection. The entire power-system is covered by several protective zones and no part of the system is left unprotected.

Fig. 25.1 (a) illustrates the meaning of protective zones. Each zone covers one of two power system components. Neighbouring zones overlap so that no 'dead spot' are left in the protected system (Ref. Fig. 25.1 b).

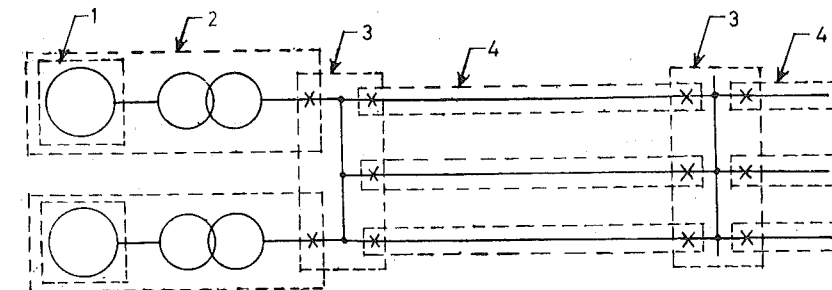

...Boundary of protective zones decided by location of CT's

- x—Circuit-breaker plus Isolators 1—Generator p.zone
2—Generator transformer unit protective zone 3—Bus bar p.zone
4—Tr. line p.zone.

Fig. 25.1. (a). Explaining protective zones.

The boundary of a protective zone is determined by the location of current transformers. Hence, current transformers are located such that the circuit-breakers are covered in the protective zones. (Ref. Fig. 17.24 Sec. 17.11, Fig. 17.2).

- G Generator
 T Main transformer of unit
 TL Transformer Lines
 1, 1' Subscript for generator-transformer unit protection system covering circuit-breakers X, X' respectively
 2 Subscript for Main Bus Protecting System covering circuit-breaker X, X' and also Y, Y'
 3, 3' Subscript for transmission line protection systems covering circuit-breakers Y, Y'

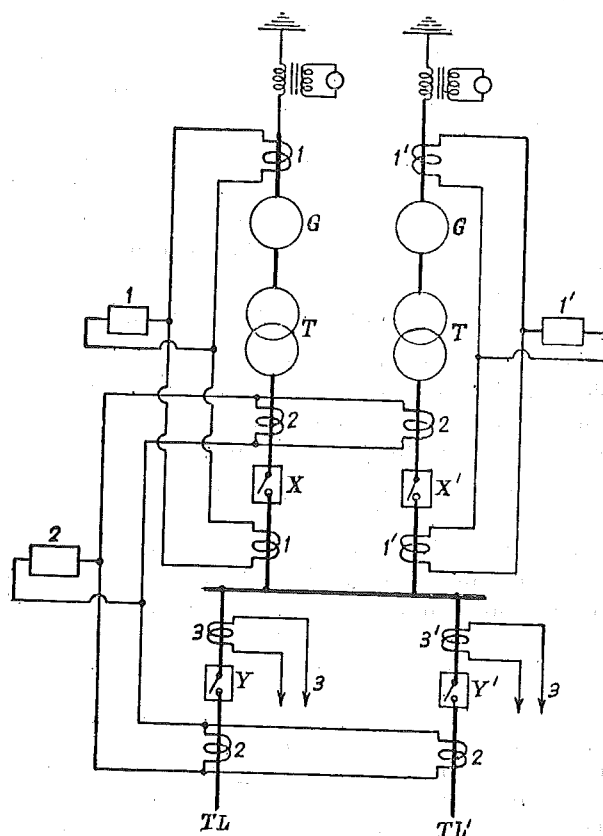

Fig. 25.1. (b) Explaining overlapping of neighbouring protective zones in a generation station.

The zones can be precisely identified in unit systems, such as circulating current differential protection of transformers. Unit system is one in which the protection responds to faults in the protected zone alone, and it does not respond to through faults (faults beyond the protected zone). Non-unit systems, such as over-current protection, do not have exact zone boundary.

Each zone has certain protective scheme and each protective scheme has several protective systems.

25.5. PRIMARY AND BACK-UP PROTECTION

Primary protection (Main protection) is the essential protection provided for protecting an equivalent/machine. As a precautionary measure, an additional protection is generally provided and is called 'Back-up Protection'. The primary protection is the first to act and the Back-up Protection is the next in the line of defence-meaning, if primary protection fails, the back-up protection comes into action and removes the faulty part from the healthy system. Back-up protection is provided for the following reasons :

If due to some reason, the Main protection fails, the Back-up protection serves the purpose of protection. Main protection can fail due to failure of one of the components in the protective system such as relay, auxiliary relay CT, PT, trip circuit, circuit-breaker, etc. If the primary protection

fails, there must be an additional protection, otherwise the fault may remain uncleared, resulting in a disaster.

When main protection is made inoperative for the purpose of maintenance, testing, etc. the Back-up protection acts like main protection. As a measure of economy, Back-up protection is given against short-circuit protection and generally not for other abnormal conditions. The extent to which back-up protection is provided, depends upon economic and technical considerations. The cost of back-up protection is justified on the basis of probability of failure of individual component in protection system, cost of the protected equipment, importance of protected equipment, location of protected equipment, etc.

The methods of back-up protection can be classified as follows :

- 1. Relay Back-up.** Same breaker is used by both main and back-up protection, but the protective systems are different. Separate trip coils may be provided for the same-breaker.
- 2. Breaker Back-up.** Different breakers are provided for main and back-up protection, both the breakers being in the same station (Ref. Sec. 43.11).
- 3. Remote back-up.** The main and Back-up protections provided at different stations and are completely independent.

4. Centrally Co-ordinated Back-up. The system having central control can be provided with centrally controlled back-up. Central control continuously supervises the load flow and frequency in the system. The information about load flow and frequency is assessed continuously. If one of the components in any part of the system fails, (e.g. a fault on a transformer, in some station) the load flow in the system is affected. The central coordinating station receives information about the abnormal condition through high frequency carrier signals. The stored programme in the digital computer determines the correct switching operation, as regards severity of fault, system stability, etc. Main protection is at various stations and Back up protection for all stations is at central control centre. The centrally coordinated back-up is a team-work of protective relaying equipment, high frequency carrier current equipment and digital computer (Ref. Sec. 43.14).

The system frequency and active power balance are closely related. Load-frequency control of the Grid is monitored by load control centres.

25.6. BACK UP PROTECTION BY TIME GRADING PRINCIPLE

This principle has been used all over the world during last several decades [Fig. 25.2]. The current is measured at various points along the current path, e.g., at source, intermediate locations, consumer end. The tripping time at these locations are graded in such a way that the circuit-breaker/fuse nearest the faulty part operate first, giving primary protection. The circuit-breaker/fuse at the previous station operates only as back-up. Referring to Fig. 25.2, the tripping time at station C, B and A are graded such that for a fault beyond C breaker at C operates as a primary protection. Meanwhile, the relays at A and B also may start operating but they are provided with enough time lag so that the circuit-breaker at B operates only if the circuit-breaker at C does not. (Ref. Sec. 30.2).

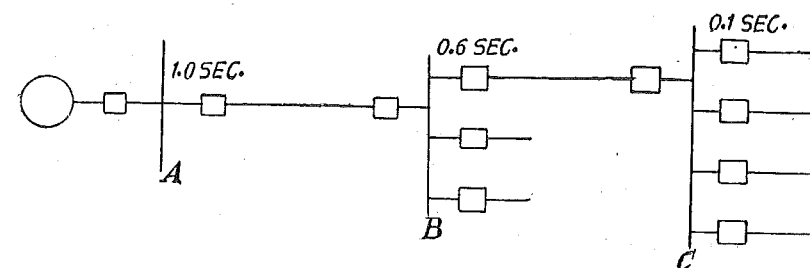

Fig. 25.2. Back up relaying by time-grading.

25.6.1. Back-up Protection by Duplication Principle

The principle is very popular in U.S.A. In this form of protection, the important protective devices (protective transformers, protection systems, relays, circuit-breakers, auxiliaries, etc.) are duplicated. Both primary and back-up protections are provided at the same station and are arranged to operate at the same speed, *i.e.* as fast as possible. Such protection is costly and the cost is justified for protection of EHV transmission lines, bus bars, large generators, large transformers, etc. If the cost of separate circuit-breakers is not justified, same circuit-breaker with two independent trip coils can be employed, one for each protection. Sometimes the Main and Back-up protection are based on different principle of operation, *e.g.* differential and over-current, so that if the main protection fails to sense the fault, the back-up protection does not fail to do so.

In protection of generator-transformer unit, differential protection is provided for generator alone plus a second-differential protection is applied to generator-transformer unit, C.B. is common.

The merits of Duplication Back-up principle are :

- Fast and almost simultaneous fault clearing, improved stability.
- Complete reliability can be assured

However, the duplication should be economically justified.

25.6.2. Monitoring

Monitoring means checking the performance. Monitoring is used as an alternative to duplicate protection. It is a continuous process of monitoring instrument transformers, relays circuit-breaker trip circuit and other components of primary protection. The monitoring devices continuously switch 'in' and 'out' and determine whether the component is in working order and operational readiness. Circuit-breakers are not actually tripped but are provided a test circuit to facilitate the monitoring. The monitoring is achieved by means of high frequency signals.

Monitoring is also used in protection transmission lines by means of power line carrier telemetering. (Ref. Sec. 44.6)

In large networks load frequency is monitored constantly. Generation is matched with load to maintain constant frequency ($50 \text{ Hz} \pm 1\%$).

The reactive power compensation required and bus-voltages are monitored constantly to ensure voltage stability.

25.7. DESIRABLE QUALITIES OF PROTECTIVE RELAYING

Protective relaying should have certain qualities. Some of these quantities cannot be expressed in form of a mathematical expressions, however, they are important. The qualities of protective relaying are named as

- Selectivity, discrimination.
- Sensitivity, power consumption.
- Reliability.
- Adequateness.
- Speed, time.
- Stability.
- System security

The qualities should be carefully considered while selecting protection schemes for power system protection. Cost is also equally important. A better protective system costs more.

25.7.1. Selectivity and Discrimination

Selectivity is a quality of being selective. A protective system should be 'selective' in protecting-meaning, the protective relaying should select the faulty part of the system and should isolate, as far as possible, only faulty part from the remaining healthy system. Discrimination is 'the act of discriminating' or 'distinguishing the difference between'. 'Discriminating quality of protective relaying enables it to distinguish between' the following :

Normal Condition—Abnormal condition.

Abnormal Condition within the protective zone—Abnormal condition elsewhere.

The protective system should operate only during abnormal conditions and should not operate under normal condition. In other words, the protective relaying system should discriminate between normal condition and abnormal condition. It should select and disconnect only faulty part without disconnecting the remaining healthy part.

Protective relaying should be inoperative and stable during faults and abnormal conditions beyond its protective zone. It should not operate for faults, abnormal conditions beyond its protective zone. Referring to Fig. 25.3, if a fault occurs on transmission line, the protective relaying should isolate only the faulty line without tripping the neighbouring line or the transformer. For fault F_1 , only circuit-breaker CB_1 should open. For fault F_2 , both CB_2 and CB_3 should open.

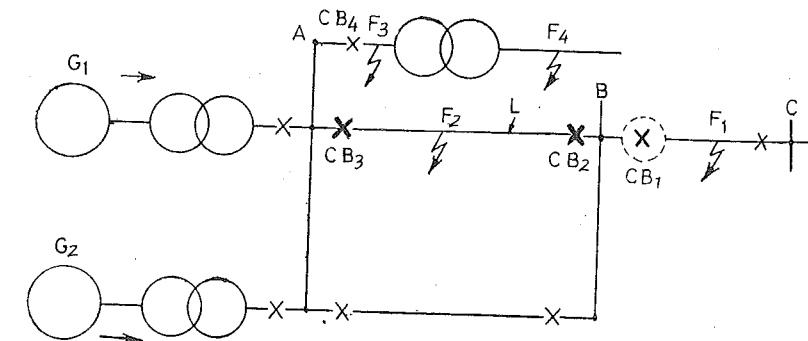

Fig. 25.3. Explaining selectivity and sensitivity.

In Unit-protective systems the selectivity is almost absolute. Such protective systems respond to faults in their protected zone alone. They do not respond to faults elsewhere. Non-unit systems of protection use some other principle (such as graded time lag, graded current feature, directional feature, distance principle, etc.) for obtaining discrimination. However, in no-unit systems, the selectivity is not exact.

If protective relaying is not selective, and operates for faults beyond its protective zones, a larger portion of the system gets disconnected unnecessarily, causing embarrassment to supplier and consumers.

25.7.2. Relay Time and Fault Clearing Time (Ref. Sec. 2.11)

Fault clearing time is the time between the instant of fault and instant of final arc interruption (in circuit breaker).

Fault clearing time is the sum of relay-time and circuit breaker-time.

Remember the time events

$$\text{Fault Clearing Time} = [\text{Relay Time}] + [\text{Breaker Time}]$$

$$\left[\begin{array}{c} \text{Fault Instant} \\ \text{to} \\ \text{Closing of} \\ \text{relay contacts} \end{array} \right] + \left[\begin{array}{c} \text{Closing of relay} \\ \text{contacts to Final} \\ \text{Arc-extinction} \\ \text{in C.B.} \end{array} \right]$$

The relay-time is the time between the instant of occurrence of fault and the instant of closure of relay contacts. Or, it is the time between the instant when the operating quantity reaches the pick-up value and the instant of closure of relay contacts.

The circuit breaker time is the total of time taken by operating mechanism to open to circuit breaker contacts and the arcing time. It is also called total break time.

The fault clearing time is significant due to the following reasons :

1. Rapid fault clearing minimizes the damage. During short circuit tests on bus bars, with fault duration of 0.07 second, with 60 kA r.m.s. value of current, no damage was observed after the tests. With fault duration of 7 seconds, however, the bus bars were completely destroyed.

2. Rapid fault clearing improves power system stability. For the reason, the slow relays and slow circuit breakers should not be preferred for protection, where stability is important. This applies to protection of EHV transmission lines, protection of large machines like important generator, large transformer, large-motors, etc., and protection in important generating stations and receiving stations.

Though fast fault clearing is desirable, time lag is purposely provided in majority of protection systems for the following purposes :

- To permit discrimination between main and back-up protection.
- To prevent the operation of relay during transients, starting currents, permissibly load fluctuations, etc.

The relay-time of fast relays is of the order of a few cycles and that of inverse time relays can be adjusted between about 6 seconds to 60 seconds. The circuit-breaker time of slow circuit-breakers is of the order of 5 cycles and that of fast circuit-breakers is of the order of 2 cycles to 3 cycles.

Static Relays of 1/2 cycle or one cycle are now available.

25.7.3. Sensitivity

Sensitivity of a protective scheme refers to the smallest value of actuating quantity at which the protection starts operating in relation with the minimum value of fault current in the protected zone.

Referring to Fig. 25.3, consider the protection system of the transmission line L . The protection system should be so sensitive that it should respond to a fault say F_2 for minimum fault current.

Minimum fault current can flow when :

Only one generator (Say G_1) is connected in the system, other generator (G_2) being disconnected.

- The fault is at the receiving end of the transmission line.
- The fault is an arcing fault, the arc path being through air, the arc resistance is high and fault current low.

The protection should be sensitive enough to act during a fault under such conditions. Sensitivity can be defined in terms of sensitivity factor K_s equal to ratio of minimum short-circuit current and minimum operating current, *i.e.*

$$K_s = \frac{I_s}{I_o}$$

where K_s = Sensitivity factor

I_s = Minimum short-circuit current in the zone

I_o = Minimum operating current of protection

The operation current should not be kept too small for following reasons :

- The protection should not operate on maximum loads.
- The protection should not operate under through fault conditions, or faults some where else in the system.

Hence the sensitivity should be chosen with due considerations to the following :

- Minimum fault current in protected zone
- Operating values required for primary and back-up protection. For example, Fig. 25.3 ; the protective scheme for busbar protection should be such that, it does not respond to fault F_2 as a primary protection. Fault F_2 should be cleared by CB_3 . However the bus-bar protection at A should provide a back-up for the protection of line L .

25.7.4. Stability

Stability is defined as the quality of protective system by the virtue of which, the protective system remains inoperative and stable under certain specified condition such as system disturbance through faults, transients, etc.

Consider protection of transformer. For faults beyond the protected zone, the protection of transformer should remain stable. To achieve such stability, the relay CT's, protective scheme design and type of disturbance are important. To improve stability certain modifications are necessary in relays design and the relay scheme. For example biased differential protection for protection of power transformer is more stable than plain differential protection. Further, to make the transformer protection insensitive to inrush of currents during switching-in, provision like Harmonic Restraint are provided. In many cases, time delay, mechanical and electrical bias, filter circuits etc. are provided to make the relays stable during certain disturbances.

25.7.5. Reliability

Reliability means trustworthiness. The protective relaying should not fail to operate in the event of faults in the protected zone. Secondly, there should not be any fault in the components of protective system. Protective system should not operate unnecessarily. Reliability of protective systems is assessed from statistical data. 'Reliability' cannot be easily specified in terms of a mathematical expression with certainty. Statistical survey and records give idea about reliability of protective systems. With increasing size of systems, use of EHV lines, interconnections and use of large generators and transformers, the importance of reliability of protective systems has increased.

The protective system is a teamwork of several components. A failure or defect in any one of them can result in failure of protection system. Hence the basic requirement of reliable protection is reliability of each component including circuit-breaker, relays, CT's, PT's secondary cables, trip circuit, battery system accessories, etc. Next the design of protection system, installation, maintenance, etc., are also very important. These aspects are mentioned in Fig. 25.4. It is clear that the reliability of protective systems depends on diverse aspects and a good reliability is a task to be shared by the protective gear manufacturers, electricity boards and associates.

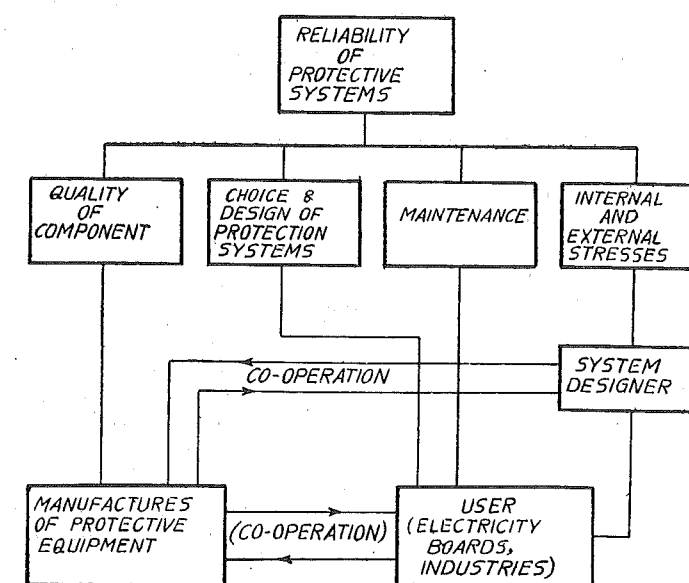

Fig. 25.4. Reliability of protective systems is influenced by several aspects.

25.7.6. Adequateness

There can be many abnormal conditions and providing protection against every abnormal condition is economically impossible. However, the protection provided for any machine, should be adequate. The adequateness of protection is judged by considering the following aspects :

- Rating of the protected machine.
- Location of the protected machine.
- Probability of abnormal condition due to internal and external causes.
- Cost of the machine, important.
- Continuity of supply as affected by failure of machine.

for low voltage machine/equipment, at the remote end of the system, an elaborate and costly protective system is not necessary. For example, distribution transformers below, say 500 kVA are protected simply by drop-out fuses. Motors below 100 kW are protected by thermal over-load relays and HRC fuses. In these cases, the cost of CT's and protective relays, circuit-breakers, etc. is not generally justified. Whereas for a large machine, say generator, a very complex protective scheme is necessary. The adequateness of protection should be assessed while planning the protection scheme. Each installation generally needs particular attention, as the protective relaying needs are influenced by local conditions.

25.8. SOME TERMS IN PROTECTIVE RELAYING

The meaning and definitions of some terms concerned with protective relaying are given here, for the sake of familiarity.

1. **Relay.** Relay is a device by means of which an electric circuit (trip circuit of alarm circuit), is controlled, (closed), by change in the other circuit. Relays are automatic. There are several types and application of relays. Relays are essential components of protective systems.

2. **Protective Relay.** A protective relay is an electrical relay used for protective of electrical devices. It is a device which closes its contacts, when operating quantity reaches certain predetermined magnitude/phase. Closing of relay contacts initiates an alarm circuit or trip circuit.

3. **Measuring Relay.** A measuring relay operates at a predetermined value of operating quantity by performing the necessary measurement. A relay in which, the operation is independent of measurement is called *all-or-nothing* relay. *All-or-nothing* relays, auxiliary relays, etc, are used to supplement the measuring relay.

4. **Trip Circuit.** The circuit comprising trip coil, relay contacts, auxiliary switch, seal in coil, battery supply, etc; which controls the circuit-breaker for opening operation.

5. **Current Transformers (CT).** These are used for measurement purpose and protective relaying purpose. Accordingly, they are called measuring CT and protective CT. The current ratio of a CT is usually high. The secondary current ratings are of the order of 5 A, 1A, and 0.1 A, the latter being used for static relays. Primary current ratings vary from 10 to 3000 A or more. Ratio error and phase angle are important aspects of CT's. The CT's play an important role in protective relaying. The Volt-Ampere rating of current transformers is low (5—150 VA) as compared with that of power transformers (a few kVA to several MVA).

6. **Voltage Transformers or Potential Transformer (V.T.).** The voltage transformers step-down the primary voltage to a secondary voltage of lower value. The standard rated secondary voltage is 110 V, 240, 440 V. The Volt-Ampere capacity of Potential Transformer is small relative to that of power transformers. The VT's are used for measurement and protection. They are accordingly called as measuring instrument potential transformers and protective potential transformers.

7. **Auxiliary Switch.** A multipoint switch which operates in conjunction with circuit-breaker and connects/disconnects certain protective, indicating and control circuits in each position, (open and close). It is placed in the switch cubicles of circuit-breakers and isolators.

8. **Fault Clearing Time.** Time elapsed between the instant of occurrence of fault and instant of final arc extinction in circuit breaker. It is expressed in milliseconds (ma) or cycles I cycle in 50 Hz system is equivalent to 1/50 second, i.e. 0.02 second.

9. **Relay Time.** Time interval between occurrence of fault and closure of Relay contact (Ref. Ch. 2).

10. **Breaker Time.** Time interval between closure of trip circuit and final arc interruption. Relay time plus breaker time is equal to fault clearing time. (Ref. Sec. 25.7.2)

11. **Stability of Power System.** Stability denotes a condition during which all the Synchronous machines in the system are in synchronism, i.e. in step with each other. [Ref. Ch. 44]

12. **Earth Fault.** A fault which involves earth (ground); e.g., single line to ground fault, double line to ground fault, arcing grounds.

13. **Phase fault.** A fault which does not involve earth; e.g, Line to line fault.

14. **Instantaneous Relay.** A fast relay having relay time of less than 0.2 second and having no intentional time lag.

15. **IDMT Relay.** Inverse definite minimum time relay, is a relay having an inverse characteristic of current vs. time, upto certain increased value of current after which the time is definite.

16. **Electro-mechanical Relay.** Conventional relay in which the measurement is performed by moveable parts.

17. **Static Relays.** Relays in which relay measurement or comparison is performed by stationary (static) circuit.

18. **Biased Relay.** A relay whose characteristic is modified by additional mechanical or electromagnetic procession such as a bias-coil, magnet, etc.

19. **Power Consumption of a Relay.** The value of power consumed expressed in VA (for a.c.) or watts (for d.c.) under certain specified conditions.

20. **Pick-up.** The operation of relay is called relay Pick-up. Pick-up value or level is the value of operating quantity which is on threshold (border) above which the relay operates and closes its contacts. Consider an over-current delay. During an injection test, suppose, the current is gradually increased. At a certain value of current, the relay contacts are on the verge of moving such that increase in current causes contacts movement. This value of current is known as pick-up value. Normally the relay setting corresponds to pick-up value.

21. **Reset, drop-out.** The value of current/voltage etc. below which the relay resets and comes back to original position.

22. **Over-current Relay.** A relay which responds to increase in current.

23. **Earth-fault Relay.** A relay which sense earth fault.

24. **Distance Protection.** A protection scheme used for protection of transmission lines in which the relay measurement is based on measuring V/I ratio at relaying point which gives a measure of distance between relay location and fault location.

25. **Differential Protection.** A protective system which responds to vector difference (phase/magnitude) between two or more similar electrical quantities.

26. **Protective Scheme.** A set of protective systems covering a particular protective zone, e.g. Transmission line protective scheme may comprise overcurrent protection system, earth fault protection system.

27. **Protective System.** A combination of components which together, performs the protective relaying. The components include CT's pilot wires, measuring relays, seconding circuits, trip circuit.

28. **SCDA.** Supervisory Control and Data Acquisition. Computer based system which performs measurement, data acquisition, data transmission, operating and control functions. (Ref. Sec. 50.4)

29. **Auto-reclosure.** The process of automatic reclosing of circuit breaker after its opening. (Ref. Sec. 44.12).

30. **Power Line Carrier (PLC).** High frequency signals sent through the power line conductors (for purpose of communication, monitoring and protection).

31. **Carrier Current Protection.** Protection of transmission line by means of power line carrier signals.

32. **Unit Protection.** Protection system in which the protective zone can be clearly identified by means of CT boundaries. Such protection does not respond to through fault. It responds to only internal faults. (e.g. Differential protection of Power Transformer).

33. **Reach. (of Distance Protection of Lines).** The limiting distance 'covered by the protection, the faults beyond which are not within the reach of the protection and should be covered by other relay.

34. **Over-reach. (of Distance Protection).** Operation of (distance) relay for a fault beyond its set protected distance (say 130%).

35. **Under reach (of distance protection).** Failure of distance relay to operate within the set protected distance (say 90%).

36. **Carrier Transfer (Inter tripping).** Carrier signal sent from one end to other end of transmission line so as to trip the circuit-breaker at the other end.

37. **Carrier Blocking.** Carrier signal sent to other end of transmission line so as to reduce the relay time at that end by shunting the step timer.

25.9. DISTINCTION BETWEEN RELAY UNIT, PROTECTIVE SCHEME AND PROTECTIVE SYSTEM

A protected equipment (say, a Generator) comes in a particular protected zone. It is protected by a 'Protection scheme'. The protection scheme has a set of protective systems, e.g. a large generator may have a protection scheme comprises overcurrent protection, differential protection, earth fault protection, and so many others. Hence, *protection scheme* comprises set of protective systems and the protection schemes is named according to the protected equipment e.g.

- generator protection (scheme)
- transformer protection (scheme)

(The word 'scheme' is generally omitted).

The term *Protective System*, or simply 'protection' is named according to the principle of operation or abnormal condition. Protective transformers and relays connected in a particular fashion for giving protection against certain abnormal condition/conditions. The protective systems are named as follows :

Names based on abnormal condition :

- Over-current protection (system)
- Earth fault protection (system)
- Reverse-power protection (system)
- Under-voltage protection (system)
- Under-frequency protection (system), etc.

Names based on principle of operation.

- Differential protection (system)
- Distance protection (system)
- Power line carrier protection (system)

(The word system may be omitted).

Relay Unit or 'Relay' is a self-contained unit comprising one or more coils, fixed and movable sub-assemblies, or static circuits, provision for plug-setting, time-setting, etc. Relay unit is an important component of the protective system. It is generally named according to its type of construction/principle of operation. It is either electromagnetic or static.

25.10. PROTECTIVE CURRENT TRANSFORMERS AND VOLTAGE TRANSFORMERS

Protective relays are generally connected in the secondary circuit of current transformers and voltage transformers (Potential Transformer). The primaries of these transformers are connected in the main power circuit.

The connection of the secondaries of protective current transformers and voltage transformers depend upon the design of protective system. In large installation, several sets of CT's and VT's are necessary for various protection systems.

Protective current transformers and voltage transformers should behave satisfactorily during transient abnormal conditions. Hence their accuracy under transient condition is very important.

25.11. ACTUATING QUANTITIES

The discrimination between normal and abnormal condition can be judged by measuring actuating quantity. The electrical relays respond to current/voltage, derived from secondaries of CT's or VT's connected to the protected equipment. During abnormal condition the actuating quantity varies according to the type of fault. For every type and location of abnormal condition, there is a distinct variation in some of the quantities. Hence the actuating quantity for the relays can be one or more of the following parameter of voltage/current derived from CT/VT.

- Magnitude
- Rate of change
- Phase Angle
- Direction
- Frequency
- Wave Shape.
- Duration (Time)
- Ratio

In recently developed system, the functions of measurement, protection, control and data acquisition are integrated. Supervisory control and Data Acquisition Systems (SCADA) are used in modern interconnected power system. (Ch. 50).

25.12. ELECTRO-MECHANICAL RELAYS AND STATIC RELAYS

The conventional electro-mechanical relays have movable sub-assemblies. The operation of such relays is based upon the following effects of electric current :

- electromagnetic attraction
- electromagnetic induction
- thermal effect, heat generated by i^2rt .

Some electromechanical relays responds to gas pressure generated due to heat of arc. (Buchholz Relay).

Static relays do not have any movable parts in their measuring system. The measurement is carried out by stationary electronic circuit. Static relays have several merits and are being increasingly used for various application. Recently 'Programmable Relays' have been introduced. (Ref. Sec. 43.13).

25.13. POWER LINE CARRIER CHANNEL (PLC)

High frequency signals are transmitted through the transmission line conductor for the purpose of communication, protection, signalling and monitoring.

Carrier current equipment are installed at the sending end and receiving end of transmission line sections.

The power line carrier equipment can be used for the following :

- to send tripping signals to the other end of transmission line so as to open the circuit-breaker at that end (Inter-tripping).
- to send signal to the remote end so as to accelerate the relays at the other end of the transmission line (carrier acceleration).
- to send blocking signal to the other end of transmission line so as to prevent tripping of circuit-breaker at that end (carrier blocking).
- carrier current protection of transmission line based on differential principle.

Carrier current signalling is used along with digital computers for network monitoring, central load control, central back-up protection.

25.14. PROGRAMMABLE RELAY

Conventional electromagnetic and static relays are hard wired relays. Their wiring is fixed. Only their setting can be manually changed. In recent years, programmable relays are introduced. They have a microprocessor in their circuit. The characteristics and behaviour of the relay can be programmed. The programme can take care of on line computation. Such relays are useful for centrally co-ordinated back-protection (Ref. Sec. 46.12).

25.15. SYSTEM SECURITY

Failures cannot be totally avoided. In a large interconnected system, one or two major faults (contingencies) may cause cascade tripping of circuit-breakers resulting in black-out over a large part of the system. Such occurrences can be avoided by installation of computerized SCADA and EMS systems in addition to the protective relaying systems. (Ref. Ch. 50).

System Security is defined as the ability of the system to operate in normal state even with occurrence of certain specified contingencies. (Ref. Sec 50.9).

25.16. ROLE OF ENGINEERS

The tasks of engineers include the following :

- Planning of protection.
- Design of protective systems, systems studies.
- Choice of protection, protective equipment.
- installation, setting, commissioning
- maintenance.
- maintaining a check on failures, assessing causes and remedies.

The engineers working in other fields such as machine designers, project engineers, manufacturers of electrical equipment, contractors, railway engineers etc. need knowledge regarding failures of equipment, their causes and remedies, and protective gear applications. Failures may be prevented by proper choice of equipment and good protective systems.

Summary

Faults are caused by insulation failure or breaking of conductors. Besides faults, there are other abnormal conditions. Protective systems prevent faults by disconnecting an equipment in the event of abnormal condition. Further, if faults develop, the protective system disconnects faulty parts. Protective system is a team of relays, circuit breaker, CT's PT's and other components. 'Sensitivity, time selectivity stability, adequateness, reliability, are the desirable qualities of protective systems. Selectivity or Discrimination is the property by virtue of which the protective relaying system distinguishes between normal condition and abnormal condition, faults in the protection zone and fault elsewhere. 'Sensitivity' of a protection refers to the minimum operating current in relation with minimum fault current in the protected zone. 'Sensitivity' of a protection refers to the minimum operating current in relation with minimum fault current in the protection zone.

'Relay time' is the time between occurrence of fault and closure of relays contacts. 'Stability' is the property of the protective relaying system by virtue of which, the protective relay remains un-operated during system disturbances and through fault conditions 'Reliability' is trustworthiness. To achieve reliability, the quality of each component, maintenance and every aspect of protective relaying is important. Reliability is improved by co-operation between manufacturers and electricity boards. Static Relays do not have movable parts in their measurement circuit.

QUESTIONS

1. Describe the faults clearing with reference to the following :
 - Components in protective system.
 - Sequence of operations between occurrence of fault and final arc extinction in circuit-breaker.
 - Fault clearing time.
2. Discuss the cause of faults and need of protective systems.
3. Fig. Q. 3 shows a portion of power system. Draw main and back-up protective zone. Showing the overlappings of neighbouring protective zones; for short-circuit protection.
4. Discuss the role of back-up protection. What are the various methods of giving Back-up protection ? (Ref. Ch. 43)
5. Discuss the back-up protection achieved in graded time over-current protection of radial transmission lines.
6. What are the merits of rapid fault clearing in case of
 1. Distribution systems ?
 2. Transmission systems ?
 Why rapid fault clearing is not possible in graded time over-current protections system ?
7. Discuss the factor influencing 'Reliability' of protective system. Suggest, how the reliability can be improved.
8. Define and explain the following :
 - Sensitivity of relay.
 - Relay time, Fault-clearing time.
 - Stability of protective system.
9. Discuss the present trends in power system protection with reference to static relay and digital computers. (Ref. Ch. 46).
10. Explain the term 'Fault clearing time'. How can the stability of a power system be improved, for given circuit configuration ?
11. State the types of faults in power system. Discuss causes the effects of faults. (Ref. Sec. 1.3, and 12.4).
12. Describe essential qualities of protective systems with reference to protection of generator. Illustrate the protective zones in a generating station layout.

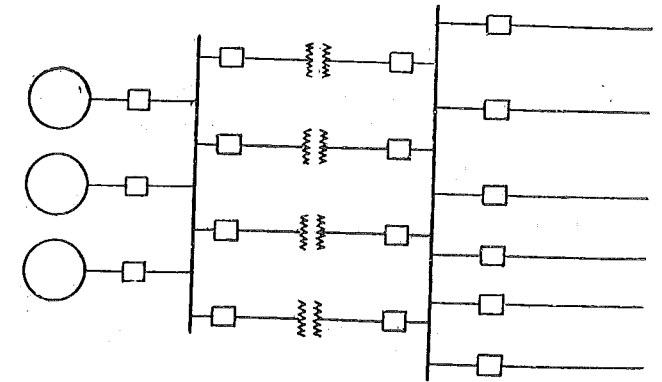

Fig. Q.3.

Note :

1. Ch. 25 Introduction to protective relaying applies to conventional and static protection systems. Ch. 26 refers to electromagnetic and electromechanical relay units only. Ch. 27 to 36 deal with abnormal conditions and protective systems which apply to both conventional and static relays. Ch. 38. to Ch. 43 deal with static relays and protection schemes. *Both electromagnetic and static relays are equally important.*
2. *Integrated Protection and Control System and Modular Configuration of Static Relays.*
In traditional electromagnetic relays and earlier generations of static relays, a separate relay unit is used for each protective function.
In the second generation of static relays, several protective functions are provided in a single modular static protection relay system. *e.g.* Motor Protection Relay provides overcurrent, earth fault, under-voltage, stalling protection etc. in a single unit.
In the third generation of static protection systems, modular microprocessor based integrated configuration is used. The functions of Measurement, Protection, Control, Data Acquisition and transmission are provided a single system. Choice of functions is based on requirements.

Electromagnetic Relays

Introduction — Definitions — Principle Types of Relays — Attracted Armature Type — Balanced Beam Relay — Induction Disc — Induction cup — Permanent Magnet Moving Coil — Thermal — Gas Operated — Operating Characteristics — Seal — in — Feature — Design Features — Auxiliary Switch — Sealing, Holding, Relay Unit, Protective Systems, Protective Schemes — Pick-up and Drop off — Rectifier Systems — Directional element — All-or-nothing Relays — Plug setting — Time Setting — Summary — Questions.

26.1. INTRODUCTION

'Relay is a device by means of which an electric circuit can be controlled (opened or closed) by the change in the same circuit or other circuit.' An electro-mechanical relay, has one or more coils, movable elements, contact system, etc. The operation of such relay depends on whether the operating torque/force is greater than the restraining torque/force *i.e.*

The relay operates, if the net Force F in Eq. (1) below is positive; or net T in Eq. (2) below is positive.

$$F = F_o - F_r \quad \dots(1)$$

F = Net Force

F_o = Operating Force

F_r = Restraining force

or

$$T = T_o - T_r \quad \dots(2)$$

T = Net torque

T_o = Operating torque

T_r = Restraining torque

Relay operates when Operating force > Restraining force

In electromechanical relays, the operating torque is produced by electromagnetic attraction/electromagnetic induction/thermal effects of electric current. The restraining torque is given by springs. The various terms such as Measuring Relay, All or-nothing relay, trip circuit, time lag relay, instantaneous relay, etc. are covered in section 25.8. They will be studied in this chapter.

The contact circuit of electromechanical relays are quite complex. Simplified diagrams have been given in this section for explaining the principle.

26.2. BASIC CONNECTIONS OF TRIP CIRCUIT

Fig. 26.1, given below, illustrates the basic connections of the circuit breaker control for the opening operation. It is rather an over-simplified diagram; for the sake of understanding the principle.

Referring to Fig. 26.1, the protected circuit X is shown by dashed line. When a fault occurs in the protected circuit, the relay (2) connected to the CT and PT actuates and closes its contacts (6).

Current flows from the battery (5) in the trip circuit (4). As the trip coil of the circuit breaker (3) is energized, the circuit breaker operating mechanism is actuated and it operates for the opening operation Auxiliary switch a is an important item in the circuit.

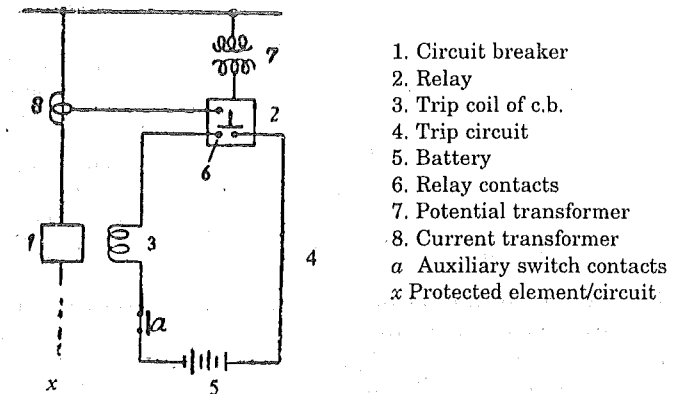

Fig. 26.1. Simplified diagram of circuit breaker control of opening operation.

26.3. AUXILIARY SWITCH, SEALING, AND AUXILIARY RELAYS

Fig. 26.1 is a simplified figure. In actual practice, the measuring relay is assisted by seal-in relay, time-delay relay tripping relay, auxiliary switch, etc. and the resulting contact circuit is quite complex. Further, there are sequential operations within the set of relays. The control circuit is further modified for schemes such as 'Autoreclosure', 'intertripping', 'anti-pumping' trip-free' Schemes. In this section, the functional details are briefly discussed.

26.3.1. Auxiliary Switch

Auxiliary switch is an important device in the trip circuit of the circuit breaker. It is a multi-point switch (4 point, 6 point, 12 point, 24 point) which is mechanically interlocked with the operating mechanism of the circuit breaker such that when the circuit breaker opens, the auxiliary switch also opens, thereby disconnecting trip circuit, certain indicating circuits and control circuits. The terminal blocks are provided in the control cabinet. The various control wiring is done *via* the terminal blocks.

The current in trip circuit is interrupted by Auxiliary Switch and not by the protective relay contacts. The relay contacts are light and delicate so that the weight of moving parts is low and consumption of relay is low. Hence relay contacts are not designed to interrupt the current in trip circuit. The trip coil consumption is of the order 7.5 watts for small oil circuit breakers to about 25 watts for large oil circuit breakers, the voltage ratings being of the order of 30, 125, 250 V.D.C. This voltage for trip current is supplied from battery system. While opening of trip circuit, (an inductive circuit), an inductive circuit is being opened and this needs a robust switching device. Auxiliary switch is designed for such a duty. Auxiliary switch is placed in the switch cubicle or control-cabinet of the circuit-breaker.

Besides the trip circuit connections, the indication circuits (to indicate whether the c.b. is 'open' or close). circuit of interlocking (between breakers, isolators and other devices) and some control circuits are also connected/disconnected by auxiliary switch.

26.3.2. 'Sealing', 'Holding', 'Repeat Operation'

As mentioned earlier, the relay contacts are designed for light weight and they are therefore delicate. The protective relay only closes its contacts and it is relieved of other duties such as time lag, tripping, (carring current for longer time, breaking trip circuit), etc. These duties are performed by 'auxiliary relays'. There are various schemes of sealing or holding. Repeat operations are performed by repeat contactors/auxiliary relays. The name 'repeat' means, these relays repeat the operations of protective relay. The repeat contactors close as the protective relay closes and they perform the function of sealing, holding. Fig. 26.2 gives a scheme in which the operations follow the following sequence. (Refer Fig. 26.2).

To begin with the circuit breaker (not shown in the figure) is closed. Therefore auxiliary switch (ASW) is closed, (as shown in the figure). If a fault occurs, protective relay operates and closes its

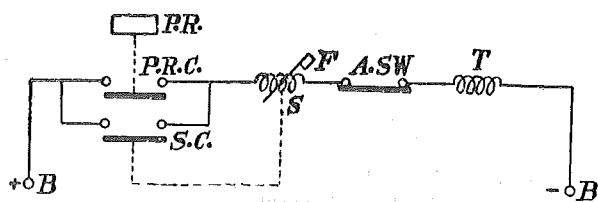

Fig. 26.2. Series Sealing Circuit, for closed position of C.B. and Auxiliary switch.

contacts (PRC). Thereby current flows from battery system (BB) through sealing coil (S), ASW contacts and trip coil (T). Circuit breaker trips. Meanwhile, the contacts (SC) operated by sealing relay (S) close and thus the contacts (PRC) of protective relay are relieved of further duty. Flag (F) operates either mechanically or electrically to indicate relay operation.

The auxiliary switch contacts open after a few cycles, as the circuit-breaker opens. The current in the trip circuit is interrupted by auxiliary switch.

There are various methods of sealing such as series sealing (described above), shunt sealing, etc. Fig. 26.3 illustrates the 'shunt Reinforcement' scheme.

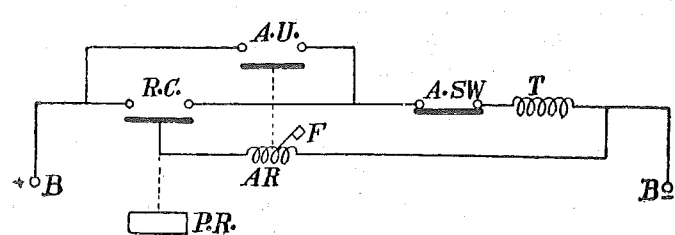

Fig. 26.3. Shunt Reinforcement Scheme for closed position of C.B. and auxiliary switch.

In this scheme, to start with, the auxiliary switch ASW is closed as the breaker (not shown) is closed. As the fault occurs, protective relay (PR) closes its contacts RC and current flows through (ASW) and trip coil (T). Meanwhile the auxiliary relay (AR) is energised and its contacts (AU) close, thereby, the relay contacts (RC) are relieved of further duty. The trip circuit is opened by ASW as the breaker opens.

The auxiliary relays mentioned above are generally attracted armature type instantaneous relays.

The 'Flag' also called 'indicator' or 'target' indicates on the relay that the relay has operated. In some relays, the movement of element of the relay pushes a small shutter to expose the indicator. In some relays the shutter is opened by electrically operated device. The resetting of indicators is usually manual. The operator notes the indication and then resets the indicator. On a relay panel, there are generally several relays. Indicators indicate, which relay has operated. Thereby the attendant knows the cause of circuit-breaker tripping.

The contact systems of static relay are quite different.

26.4. MEASUREMENT IN RELAYS

The discrimination involves measurement of actuating quantities (voltage and current) which are present at the relaying point. (Ref. Sec. 25.11) by protective relays. The measurement in majority of protective relays can be grounded as follows :

- Magnitude measurement such as over current, overvoltage, undercurrent.
- Product measurement such as power ($VI \cos \phi$)
- Ratio measurement such as impedance (V/I).
- Comparison between similar electrical quantities such as vector difference between currents I, I .

PR	Protective Relay
PRC	Contacts of Protective Relay
SC	Sealing contacts
S	Sealing Coil (in series with trip circuit.)
F	Flag indicator.
ASW	Auxiliary Switch Contacts (operation in conjunction with breaker)
T	Trip Coil of CB
B—B	Supply from battery, 110 V.D.C.

RC	= Relay contacts
PR	= Protective Relay
AR	= Auxiliary Relay
AU	= Contacts of AR
ASW	= Auxiliary switch (shown closed) operator in conjunction with breaker
T	= Trip coil
F	= Flat
B—B	= Battery voltage 110 V.D.C.

26.4.1. Magnitude Measurement

The relays under this category respond to magnitude of actuating quantity such as current derived from group of CT's.

Some other relays are energized by magnitude of voltage derived for group of VT's.

Some relays are energized by voltage and respond to parameter such as frequency, waveform, rate of rise. Such relays also can be included in this category.

The actuating quantity fed into the relay is derived from secondaries of CT's or VTs or both. Hence the performance of the protective system depends upon the resultant output of the secondary current/voltages fed into the relay.

The relays can be single actuating quantity type or multi-actuating quantity type.

26.4.2. Product Measurement

The double actuating quantity type induction relay have two coils and are actuated by voltage and current. Thereby two fluxes are produced and the torque produced by their interaction is given by,

$$T = kVI \cos \phi$$

k being a constant. Thus, the relay can be arranged to respond to the product of two quantities.

26.4.3. Ratio Measurement

The relay can be arranged to operate for a particular setting of the ratio say V/I .

One coil of the relay is actuated by voltage V and gives a force $F_1 = k_1V$.

The other coil is energized by current I and gives a forces $F_2 = k_2I$ when the relay is on the verge of operation, F_1 and F_2 are equal,

$$k_1V = k_2I$$

Hence

$$\frac{V}{I} = \frac{k_1}{k_2} = k$$

26.4.4. Vector Difference (or Vector Sum)

The relay element can be connected in the secondary circuit of the CT's in such a way that the vector difference of secondary currents passes through the relay coil. Such arrangement gives a resultant current.

$$\bar{I} = (\bar{I}_1 + \bar{I}_2 + \bar{I}_3)$$

The relay operates when \bar{I} increases above certain value.

26.5. TYPE OF RELAYS UNITS

- (a) Attracted Armature type (Electromagnetic) Relay
- (b) Balanced Beam (Electromagnetic) Relay
- (c) Induction Disc (Electromagnetic) Relay
- (d) Induction Cup (Electromagnetic) Relay
- (e) Moving Coil and Moving iron (Electromagnetic) Relay
- (f) Gas operated (Buchholz) Relay (Gas pressure)
- (g) Rectifier Relays (Rectifier plus moving coil unit)
- (h) Static Relay (static electronic circuit for measurement)

The electro-magnetic relay operates when operating torque/force exceeds the restraining torque/force.

26.6. PICK-UP

When the relay operates, we say, the relay has picked-up. It simply means that the relay with normally open contacts, has closed its contacts.

The pick-up value or pick-up level is the minimum value of operating quantity at which the relay is one the verge of operation, *e.g.*, consider an over current relay. The current injected in the relay coil is very gradually increased. At a current value of 2.51 amperes, the relay has not operated, at a value of 2.52 amperes, the relay begins to operate. Then, 2.52 amperes is the pick-up value.

In some attracted armature type relays, moving iron and moving coil relays, the pick-up value can be changed by changing the spring-tension.

In induction disc relays, the pick-up value corresponds to plug-setting (described later). If plug setting is 2.5 A, the relay starts operating at 2.5 A. If plug setting is 3.5 A, relay starts operating at 3.5 A and so on. However, in such relays the pick-up value is not exact, within about 5% of plug setting. The relay may not pick-up exactly at the plug setting value due to errors introduced by dust, friction, adjustment errors; and because operating torque is minimum at pick-up value.

26.7. RESET OR DROP-OFF

Now, we are talking about the relay which has already operated, and the actuating current is still flowing in the relay coil. As the operating quantity is gradually reduced, at some maximum value, the relay value, the relay contacts which have closed, start opening. This condition is called Reset or Drop off.

The value of operating quantity at which the relay (normally open) contacts which were closed due to relay operation, start opening and coming to original state (open).

26.8. DROP OFF/PICK-UP RATIO

The ratio of 'drop-off value to pick-up value' is important in self-reset type electromagnetic relays. It is also called 'Holding Ratio'. Since 'pick-up' value is more than 'drop off value, the holding ratio is always less than 1.

The drop out to cut off ratio is of the order of 0.6 to 0.99 for most electromagnetic relays.

26.9. ATTRACTED ARMATURE RELAY (ELECTROMAGNETIC ATTRACTION)

These are simplest type of relays. These relays have coil or an electromagnet energized by coil. The coil is energized by the operating quantity which may be proportional to circuit current or voltage. A plunger or rotating iron vane is subjected to the action of magnetic field produced by the operating quantity. It is basically a single actuating quantity relay.

1. Attracted armature relays respond to both a.c. and d.c. because torque is proportion to I^2 .

2. The attracted armature relays are fast relays. They have fast operation and fast reset because of small length of travel and light moving parts.

3. They are described as instantaneous. But their operating time does vary with current. Slow operating and resetting times can be obtained by delaying in build up of or decay of flux in the magnetic circuit by fitting copper ring around the magnet, and by means of bellows, dash pots, escapements etc. Operating time as slow as 0.1 sec. and resetting time as slow as 0.5 sec. can be obtained by such means.

4. On the other hand, very high operating speeds are possible. One modern relay has 0.5 millisecond of operating time. The current/time characteristic is hyperbolic (Fig. 26.5).

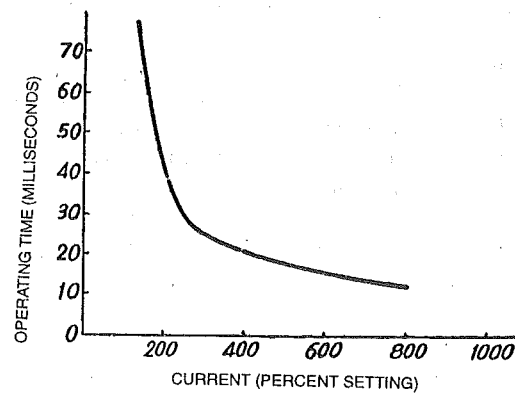

Fig. 26.5. Time current characteristic of a typical attracted armature relay.

5. **Ratio Rest to Pick-up** can be as high as 90-95% for a.c. relays and 60 to 90% for d.c. relays, by means of special design features. But in general the difference between picked-up and reset values is high because once, the relay has picked up the air gap is shortened and smaller magnitude of coil current can hold it in picked up position.

(Refer definitions, section 26.8)

6. These relays do not have directional feature unless they are provided with additional polarized coil.

7. As they are fast and operate on d.c. and a.c., they are affected by transients. The transients contain d.c. component in addition to a.c. wave. Therefore, though the steady state value may be less than relay's pick-up the relay may pick-up during transient state.

8. VA burden depends on construction, setting etc. For a typical relay it is of the order of 0.2 to 0.6 VA for current range 0.1 to 0.4 A.

9. Modern attraction armature relays are compact, robust, reliable.

10. **Operating Principle.** The electromagnetic force exerted on the moving element is proportional to square of the flux in air gap. If saturation is neglected it is proportional to square of operating current. We get

$$F = K_1 I^2 - K_2$$

where F = net force

K_1 = a constant

I = current in operating coil

K_2 = restraining force including friction.

When relay is on the verge of operation, F is zero

$$K_1 I^2 = K_2$$

Hence $I = \sqrt{\frac{K_2}{K_1}}$ a constant.

11. **Types of Constructions.** There is a variety. Fig. 26.6 illustrates a few types of structures of attraction armature type of relay.

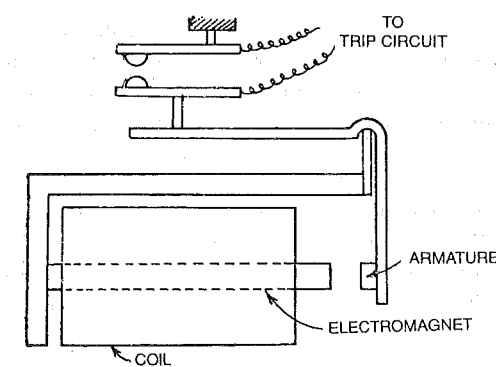

(a) Hinged armature type relay.

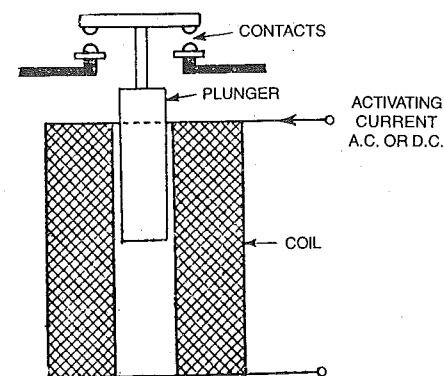

(b) Plunger type electromagnetic attraction relay.

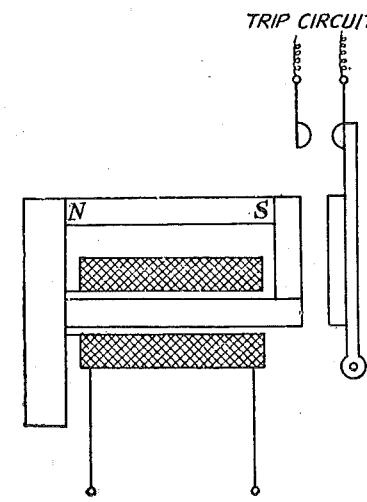

(c) Polarised moving iron type

Fig. 26.6. Attracted armature relay.

Applications of Attracted Armature type Electromechanical Relay

Attracted armature relays have many applications in protection of a.c. and d.c. equipment. They are however instantaneous relays and are sensitive to starting currents, load fluctuations and current surges.

Attracted armature relays can be designed to respond to over/under current, over/under voltage, for both a.c. and d.c. applications. They are used as measuring relays or auxiliary relays. Their most usual applications are :

- Over-current protection, the time lag is obtained by using instantaneous attracted-armature relays in conjunction with a definite time lag relay or inverse time lag relays.
- Definite-time lag over-current and earth fault protection, the attracted armature relay is used in conjunction with definite-time-lag relay for over-current/earth fault protection.
- Differential protection, the instantaneous attracted armature type relay is used for differential protection.
- Auxiliary Relays. Attracted armature relays are used as auxiliary all-or-nothing relays, in the contact systems of protective relaying.

26.10. BALANCED BEAM RELAY (ELECTROMAGNETIC ATTRACTION PRINCIPLE)

This type of balanced beam relay (Fig. 26.7) consisted of a horizontal beam pivoted centrally, with one armature attached to either side. There were two coils, one on each side. The beam remained in horizontal position till operating force became more than restraining force. The action being similar to 'see saw' in children park in which a plank is balanced on a support at the middle. Children ride at the ends so that when one end goes up, the other comes down. In a balanced beam relay, coils act like those playing children. The current in one coil gives operating force the current in other coil gives restraining force. The beam is given slight mechanical bias by means of spring or weigh adjustment such that under normal condition the contacts are open. When operating torque increases, the beam tilts and the contacts close. In current balance both coils are energized by current derived from C.T's. In impedance (balance) relay the coils are energized by V and I .

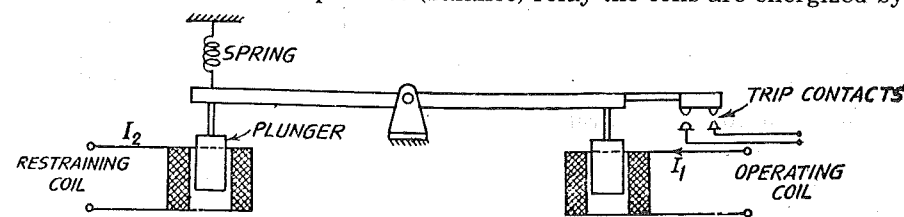

Fig. 26.7. Balance beam relay of early days.

Operating principle. Neglecting spring effect, the net torque is given by

$$T = K_1 I_1^2 - K_2 I_2^2$$

where T = net torque
 I_1 = current in operating coil
 I_2 = current in restraining coil
 K_1, K_2 = constants.

At the verge of operation, net torque is zero, therefore,

$$K_1 I_1^2 = K_2 I_2^2$$

$$\frac{I_1}{I_2} = \sqrt{\frac{K_2}{K_1}} = \text{constant.}$$

The operating characteristic is shown in Fig. 26.8 which is an approximate straight line, slightly curved for low currents due to effect of spring. The current which gives operating torque or positive

torque is called operating current. The other one is called restraining current. If one of the coils is actuated by voltage say V_1 other by current I_2

then the equation is $\frac{V_1}{I_2} = K$ is constant. This principle is used in impedance relays.

1. Balanced beam relay is difficult to be designed over a wide range current because the force is proportional to I_2 .

2. The relay of this type is fast and instantaneous. In modern relays, electromagnets are provided in place of air-cored coils. Such relays can have time of the order of 1 cycle.

3. High ratio of resetting quantity of operating quantity can be obtained.

4. This relay is largely superseded by permanent magnet moving coil relay having better accuracy and lower VA burden.

5. VA burden of balanced beam relay depends on application. In current balance type the VA burden is of the order of 0.2, 0.4, 0.6 VA for 0.1 to 0.6 A range.

26.11. INDUCTION DISC RELAY (ELECTROMAGNETIC)

In this type of relay a metal disc is allowed to rotate between two electromagnets. The electromagnets are energized by alternating currents. The fields produced by the two magnets are displaced in space and phase. The torque is developed by the interaction of the flux of one of the magnets and the eddy currents induced in the disc by the other.

There are two popular constructions :

- Shaded pole induction disc relay (Fig. 26.9)
- Watthour meter type induction disc relay (Fig. 26.12).

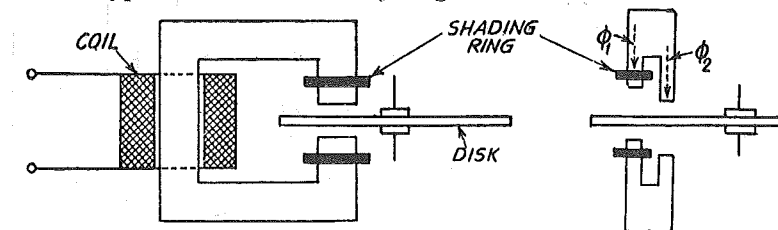

26.9. Shaded Pole Construction.

Referring to Fig. 26.9, the shading ring is a copper band or a coil. Effect of shading ring is to produce flux in the shaded portion of the magnet (ϕ_1) which is displaced in phase and space from the flux in the remaining portion (ϕ_2). The flux ϕ_1 induces e.m.f. E_1 in the disc at 90° to ϕ_1 . The e.m.f. E_1 produces currents I_1 lagging behind E_1 by small angle. The interaction between I_1 and ϕ_2 produces torque, which is proportional to $\phi_2 I_1 \cos \alpha$, where $I_1 \cos \alpha$ is component of I_1 in phase with ϕ_2 . Greater the angle θ , greater is the torque.

The torque equation of single quantity induction relay may be expressed as

$$T = K_1 I^2 - K_2$$

where T = Net torque
 I = Current in relay coil
 K_1, K_2 = Constants.

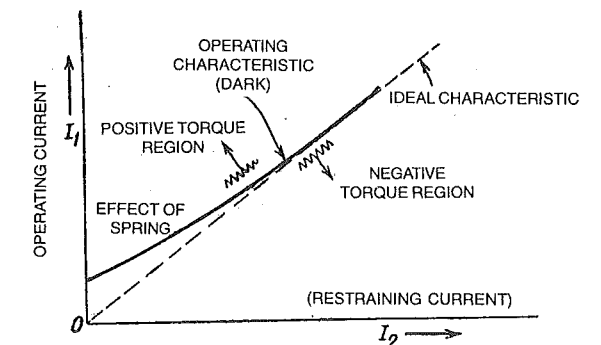

Fig. 26.8. Operating characteristics of balanced beam relay.

ϕ_1 = Flux in shaded portion of magnet
 ϕ_2 = Flux in unshaded portion of magnet
 E_1 = e.m.f. induced in the disc due to ϕ_1 .
 I_1 = Current in the disc induced by E_1 .
 Torque $\propto \phi_2 I_1 \cos \alpha$.
 α = angle between ϕ_2 and I_1 .

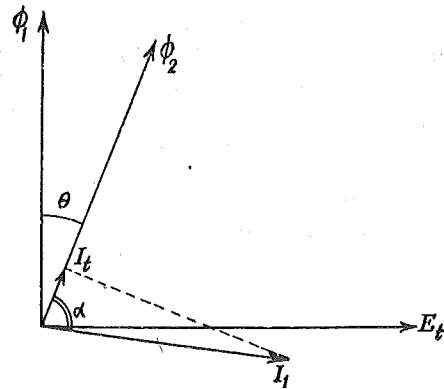

Fig. 26.10. Vector diagram of fluxes and current, for shaded pole induction disc relay.

Similar results are obtained by Watthour meter type induction disc relay (Fig. 26.12). The construction of this relay is similar to the watthour meter commonly used everywhere. It consists of an E-shaped electromagnet and a U-shaped electromagnet with a disc free to rotate in between. The E-shaped magnet produces flux ϕ_1 and the U-shaped magnet produces flux say ϕ_2 . The phase angle θ between the fluxes is adjusted by a reactance in parallel with the secondary winding.

Torque is produced by interaction between flux and the eddy currents in the disc (produced by flux ϕ_1 and ϕ_2). The relay coil is tapped at several points. The current setting is selected by inserting a knob to take desired number of turns of the coil in the circuit.

1. The operation of induction relay can be controlled by opening secondary coil, as opening of this coil makes relay inoperative.

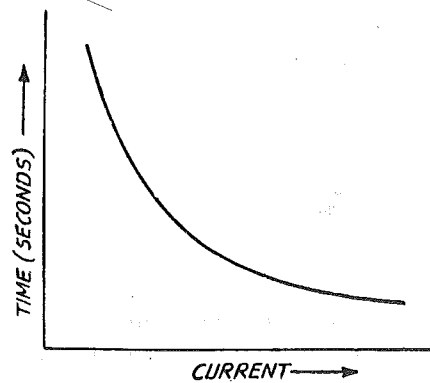

Fig. 26.11. Inverse characteristic.

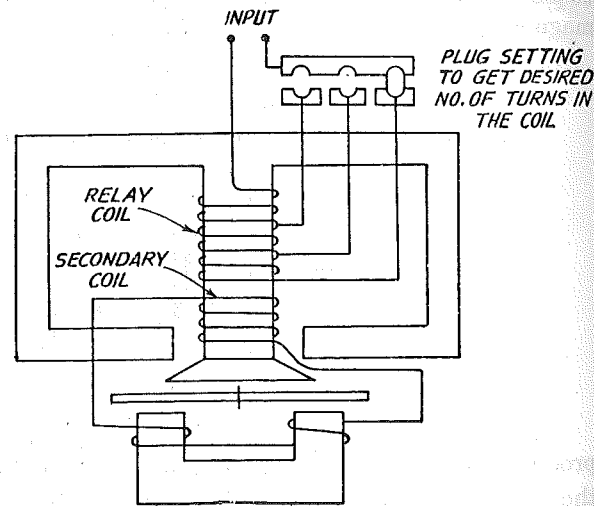

Fig. 26.12. Watthour meter type induction disc relay.

2. The time/current characteristics of induction disc relay is inverse characteristic (Figs. 26.11 and 26.14). The time reduces as current increases.

3. The VA burden depends on rating. It is of the order of 2.5 VA.

4. Modern induction disc relays are robust and reliable.

5. The current setting can be changed by taking the suitable number of turns. The time setting can be obtained by changing

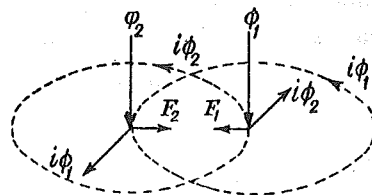

Fig. 26.13. Torque production in an induction relay.

the relative position of contacts by adjusting the length of travel of moving contacts.

6. The effect of d.c. offset may be neglected with inverse time single quantity induction relay, because they are generally slow. The d.c. offset may effect fast relays.

7. Ratio of reset of pick-up is high because operation does not involve any change in air gap. The ratio is above 95%.

8. **Operating time.** Inverse time characteristic is obtained by disc relays (Fig. 26.12). It is 10 to 60 sec.

Torque Equation of an Induction Disc Relay

Let $\phi_1 = \phi \sin \omega t$

and

$\phi_2 = \phi \sin (\omega t + \theta)$

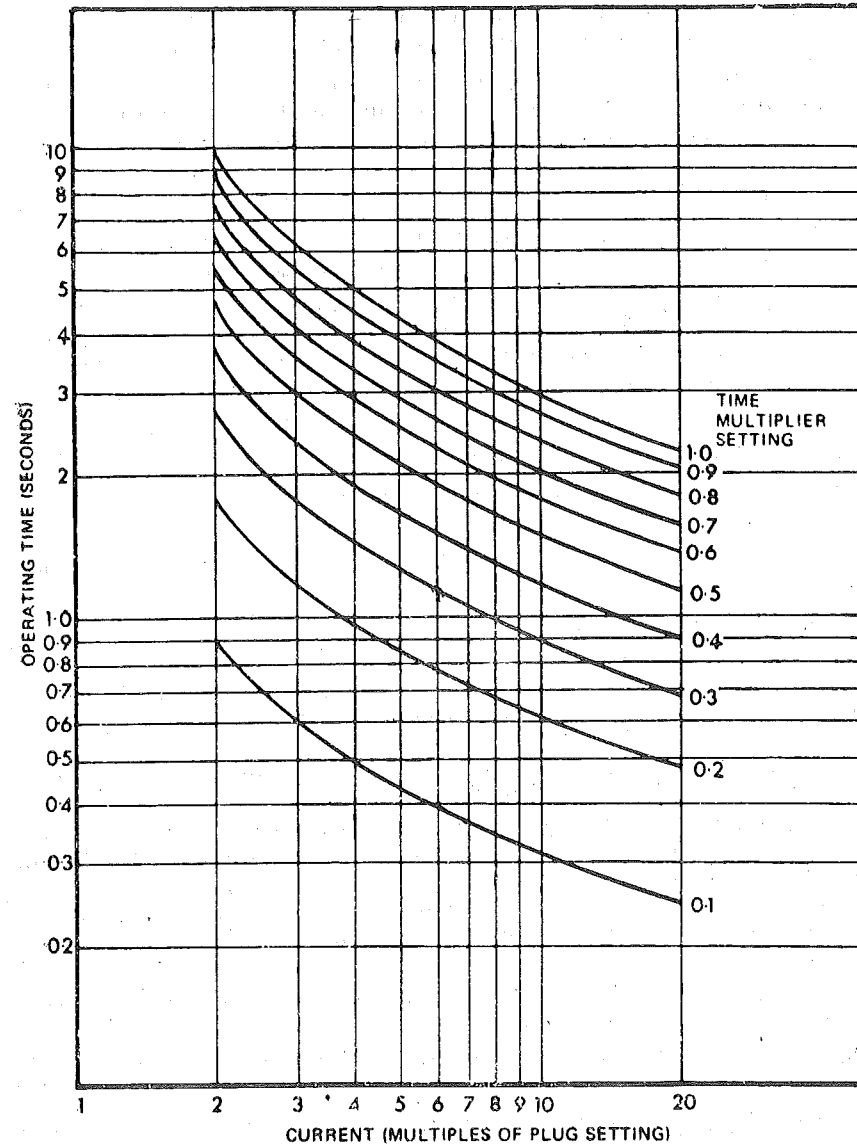

Fig. 26.14. Inverse characteristics of induction disc relays on log scales.

be the two fluxes at a phase difference of θ and which produce eddy currents $i\phi_1$ and $i\phi_2$ in the disc.

$$i\phi_1 = \frac{d\phi_1}{dt} \propto \phi \cos \omega t$$

$$i\phi_2 = \frac{d\phi_2}{dt} \propto \cos(\omega t + \theta)$$

$$F = (F_2 - F_1) \propto \phi_2 i\phi_1 - \phi_1 i\phi_2$$

where F is net force due to interaction between ϕ_2 and ϕ_1 . F_1 is force due to interaction between ϕ_1 and ϕ_2 .

$$F \propto \phi_1 \phi_2 [\sin(\omega t + \theta) \cos \omega t - \sin \omega t \cos(\omega t + \theta)] \\ \propto \phi_1 \phi_2 \sin \theta.$$

26.11.1. Plug Setting and Time Setting in Induction Disc Relays

In these relays, there is a facility for selecting the plug setting and time setting such that the same relay can be used for a wide range of current, time and characteristics.

Time multiplier setting is generally in the form of an adjustable back-stop which decides the arc-length through which the disc travels, by reducing the length of travel, the time is reduced. The time multiplier setting is marked from about 0.1 to 1, with major divisions marked in between. If relay takes a certain time, say S seconds with time multiplier setting 1, the same relay will take time equal to $T \times S$ seconds for time multiplier setting T , other conditions remaining the same.

The arrangement is such that for various plug settings, the ampere-turns (amperes of plug setting \times turns of coil corresponding to the plug setting) are constant for various plug settings. Thereby, the relay characteristics remains the same for various plug settings, for a given time setting. Actually, the relay should start operating at current equal to plug setting. However, due to friction, dust etc. the operations may not take place at exact plug setting value.

The relay characteristic is plotted with multiples of plug setting as an abscissa (log scale) and time in seconds (log scale) as ordinate. Suppose, current injected in relay coil is 10 Amp and plug setting is 2.5 Amp., then plug setting multiplier will be $10/2.5 = 4$.

Fig. 26.14 illustrates typical characteristics of induction disc relays, on log scales.

26.11.2. Effect of Time-setting

By reducing the time multiplier, the characteristic is shifted to lower side, indicating that operating time is reduced (Fig. 26.14).

Plug Setting bridge is provided with induction disc relays and it provides a wide range of current settings. The plug setting refers to the magnitude of current at which the relay starts to operate. The plug setting bridge comprises connections tapped from relay coil. By inserting the plug, in a particular gap in the bridge, a certain number of turns of the relay coil are brought into circuit.

26.12. INDUCTION CUP RELAY (ELECTROMAGNETIC)

This relay has two, four or more electromagnets, in stator. These are energized by the relay coils. A stationary iron core is placed as shown in Fig. 26.15. The rotor consists of a hollow metallic cylindrical cup. The rotor is free to rotate in the gap between the stationary iron and the electromagnets. In this type of relay, the eddy currents are produced in the metallic cup. These currents interact with the flux produced by the other electromagnet and torque is produced. The theory is similar to that of the disc type induction relay.

In Fig. 26.15 structure employing four poles is shown. It has an iron core at the centre and a metal cup between the core and electromagnet.

Fig. 26.15 shows a two pole structure. The two fluxes ϕ_1 and ϕ_2 are at right angles and produce eddy current in the cup. Thereby torque is produced.

1. Modern induction cup relays have 4 or more poles. A control spring and moving contacts are carried on an arm attached to the spindle of the cup.

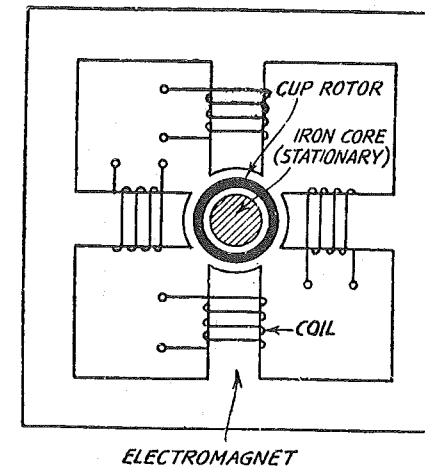

Fig. 26.15. Induction cup structure.

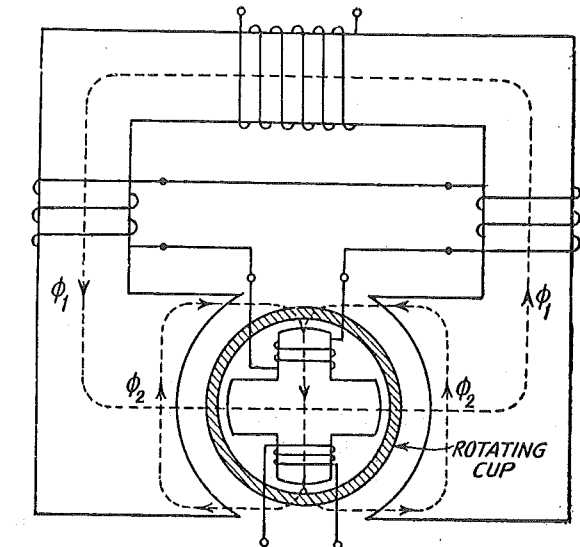

Fig. 26.16. Two pole induction relay.

- The relay can be responsive to voltage or current. Similar structures are used in either cases.
- The double actuating quantity relay can be responsive to both voltage and current.
- The operating time characteristic depends on the type of structure. The relays have inverse time characteristic.

A modern induction cup relay may have an operating time of the order of 0.010 second.

26.13. PERMANENT MAGNET MOVING COIL RELAY

In this relay the coil is free to rotate in the magnetic field of a permanent magnet. The actuating current flows through the coil. The torque is produced by the interaction between the field of the permanent magnet and the field of the coil.

1. The relay responds to d.c. only. However it is used in a.c. systems in conjunction with a rectifier.

2. The characteristic is varied by adjusting the control spring. The time setting is obtained by adjusting the position of the contact.

3. The operating torque is proportional to current in the coil. The force on the coil side is given by

$$F \propto NHIL$$

where F = Force
 H = Magnetic field vector in the gap
 I = Current in the coil
 L = Length of the coil.

and torque is given by $T = 2rF$

where r = Radius of coil

4. The time/current characteristic of such relays is shown in Fig. 26.18. It is an inverse characteristic.

5. The relay of this kind has uniform torque for the various positions of the coil. Hence it can be accurately set. Theoretically the reset value is equal to operating value.

6. Another popular type of moving coil construction is shown in Fig. 26.19. The coil is supported axially and moves horizontally when current is passed.

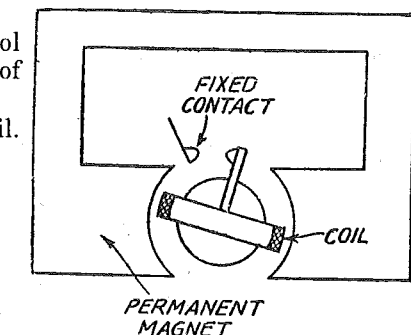

Fig. 26.17. Permanent magnet moving relay.

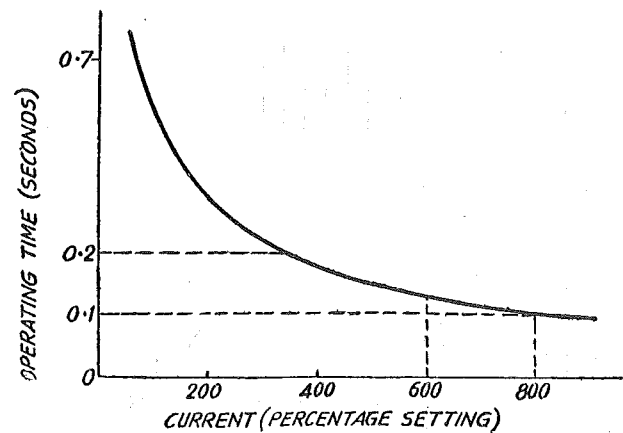

Fig. 25.18. Current-time characteristics of a typical moving coil permanent magnet relay.

This relay is faster than the rotating coil type because of the small travel, light parts. Time of the order of 30 m sec. can be obtained. VA burden is small. Sensitivity can be made as low as 0.1 milliwatt. Axial moving coil relays are delicate and should be handled with care.

26.14. RECTIFIER RELAY SYSTEMS

(Courtesy : Brown Boveri Ltd., Switzerland.)

The moving coil relays are being increasingly used with rectifier relays. In such relays, the quantities to be measured are rectified and then fed to the *moving coil unit*.

The principle and applications of such relays will now be briefly outlined (Fig. 26.20).

In the systems which measure rectified quantities, henceforth referred to as rectifier relays, the measuring element is a polarized moving-coil relay. This relay integrates the arithmetic mean value of the measured quantity. On account of the time taken by integration, it is not possible to gain the high measuring speed of electronic relays. However, the rectifier relays are faster than the mechanical relays since the moving coil has a very small mass.

26.14.1. Relays for One Quantity [Fig. 26.20.1]

As Fig. 26.20 shows the design of a relay for one quantity is quite simple. It comprises an input network, the rectifier and the moving-coil measuring system.

In the input network the measured quantity supplied by the main instrument transformer is converted into a form in which it can be processed. The network has setting resistors and an auxiliary transformer which, apart from converting the measured quantity, also serves as an insulating transformer.

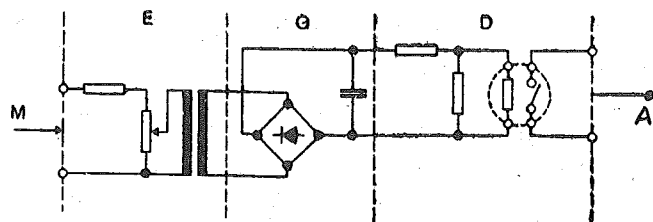

Fig. 26.20.1. Rectifier relay for one quantity.

The quantity is rectified in a full wave bridge (full-wave rectifier with centre tap). It may be equipped with smoothing elements.

The rectified quantity is then fed to the moving-coil measuring system, which is usually equipped with series and parallel resistor for adjustment of the pick-up value. The contact of the moving-coil system actuates the tripping relay and signalling device.

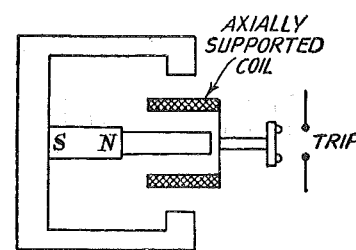

Fig. 25.19. Moving coil relay with axial moving coil.

26.14.2. Relays for Two Quantities

In the relays for two measured quantities (Fig. 26.20.2) the two rectifier bridges are interconnected on the D.C. side in opposition and the moving-coil system is inserted between the two connections.

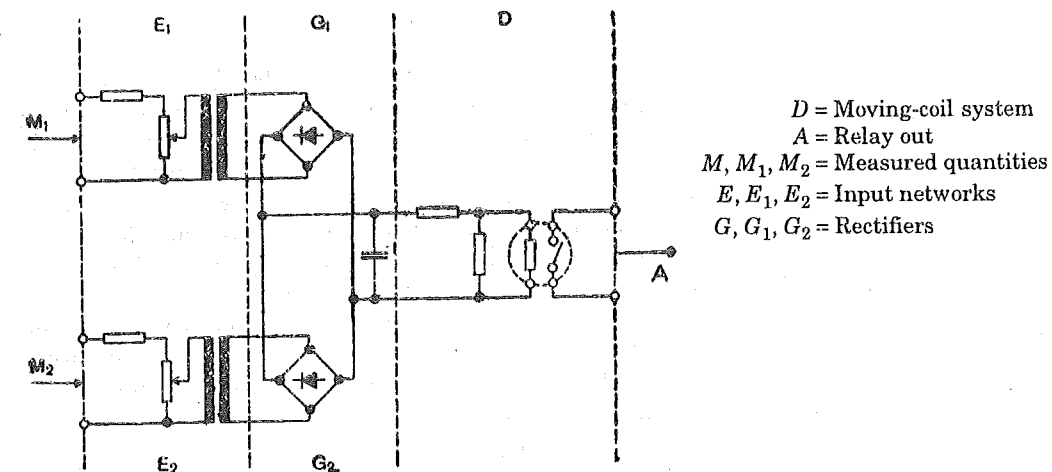

Fig. 26.20.2. Rectifier relay for two quantities.

The measurement is thus based on the comparison of the two quantities in a bridge circuit according to the electrical balance principle. Since rectification eliminates the influence of frequency and phase angle, this comparison amounts to arithmetical subtraction of one current from the other.

The contacts of the moving-coil system either move in the tripping direction or stay in the blocking position, depending on which current is greater.

By choosing suitable input networks, not only can the measured quantities be compared with one another, their product or quotient can also be determined.

26.15. THERMAL RELAYS, BIMETAL RELAYS, THERMOCOUPLES

Thermal Relays. These relays operate the thermal effect of electric current. Generally, they do not measure the temperature directly.

Thermal relays sense the current by the temperature rise produced by the current. Thermal relays can also respond to unbalanced three phase currents, which cause rise in temperature due to their negative sequence component.

The simplest thermal relay used in motor starters, overload protection devices employ a bimetallic strip mounted above a resistance wire wound heater coil. The passage of current through the coil causes the bi-metallic strip to deflect and thereby close the relay contacts. A system of levers is arranged to obtain the closure compensation for ambient temperature arranged is usually provided by another bimetal strip, shielded from heater coil and arranged to oppose the bending of main bi-metallic strip.

The bimetal strip consists of two metal strips having different coefficient of (thermal) expansions joined together. As the combined strip is heated, one strip expands more than the other. One support is fixed and uneven expansion causes bending of the strip. This effect can be used to obtain closure of relay contacts.

Temperature Indicators and controllers employing thermocouples are becoming extremely popular in various temperature indicating and controlling devices for higher (above 60°C) temperature range. They are finding their way in protective relaying too. A thermocouple consists of a junction of two selected materials, the junction is connected in electric circuit. The difference in

temperature between the hot junction and cold junction induces e.m.f. This e.m.f. is measured by a sensitive moving coil element.

Resistance temperature measuring devices employ the principle that the resistance of conductors increases with the temperature. The change in resistance is used for measuring the temperature. In large generators resistance temperature detectors are provided to measure temperature of stator winding.

In case of 3-phase motor, triple-pole bimetal relays are used. The bending of bimetal strip causes the movement of a common lever, which in turn operates the trip contact or trip lever in case of over load. The bimetal strip is heated directly by the current flowing in through it or by spacing heating coil. In case of bigger motors they are connected *via* current transformers.

Eutectic Alloy Relays operate on a different principle. In such relays a special alloy "Eutectic Alloy" is used. It is filled in a tube. When heated to a certain temperature, the alloy melts. A heater coil, which is in series with motor circuit encircles the above mentioned tube filled with Eutectic Alloy. When the current supplied to motor increases, the alloy melts and thereby the ratchet is released, thereby the contacts open by spring mechanism. Under normal conditions the Eutectic Alloy is solid and the control circuit is not closed. As soon as the Eutectic relay operates the coil is disconnected and the alloy cools and solidifies. Control circuit can be reset manually.

Winding thermostat usually comprises a tube containing a bimetal operated snap switch. The thermostat can be embedded in a motor winding. The snap switch can have normally open (NO) or normally closed (NC) contacts, and is to trip motor contactor or circuit breaker. Further details are given in the chapter "protection of Motors". (Acknowledgements to : Mr. V.S. Bhatia, Siemens Paper : Over-load protection of motors, *Courtesy* : Siemens India Ltd.).

26.16. DIRECTIONAL RELAYS

26.16.1. Principle of Measurements

Active-power flowing through a part of an electric circuit is given by

$$P = VI \cos \phi$$

where ϕ is a phase angle between I and V

The reactive power is given by $VI \sin \phi$

Referring to Fig. 26.21 (a).

For $270^\circ < \phi < +90^\circ$, $\cos \phi$ is positive, hence real power P is positive.

For $\phi = 90^\circ$ and 180° , real power P is zero.

For $+90^\circ < \phi < +270^\circ$ real power P is negative. Therefore the power flow can be sensed by sensing the magnitude and sign of $VI \cos \phi$. The voltage coil of the directional relay is supplied from secondary of voltage-transformer. The current coil is supplied from the secondary of current transformer. [Ref. Fig. 26.21 (b)].

The directional relay senses the power and responds if the power is positive. (For further details Ref. Sec. 26.16.4).

26.16.2. Directional Relays

Directional protection responds to flow of power in a definite direction with reference to the location of CT's and PT's Directional relays respond to the magnitude and sign

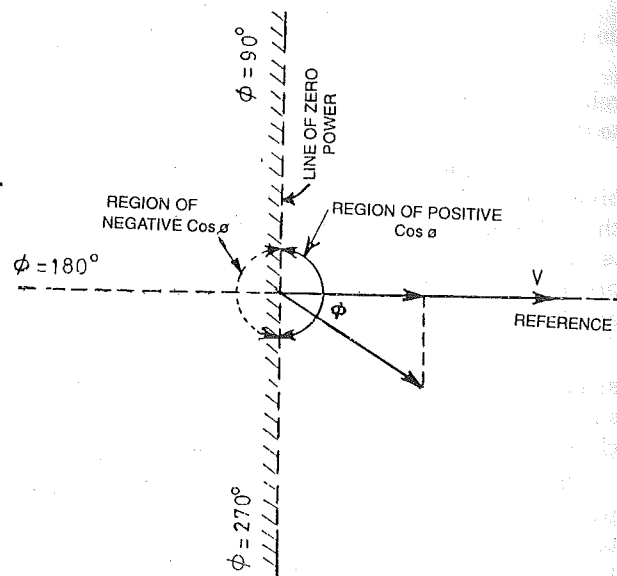
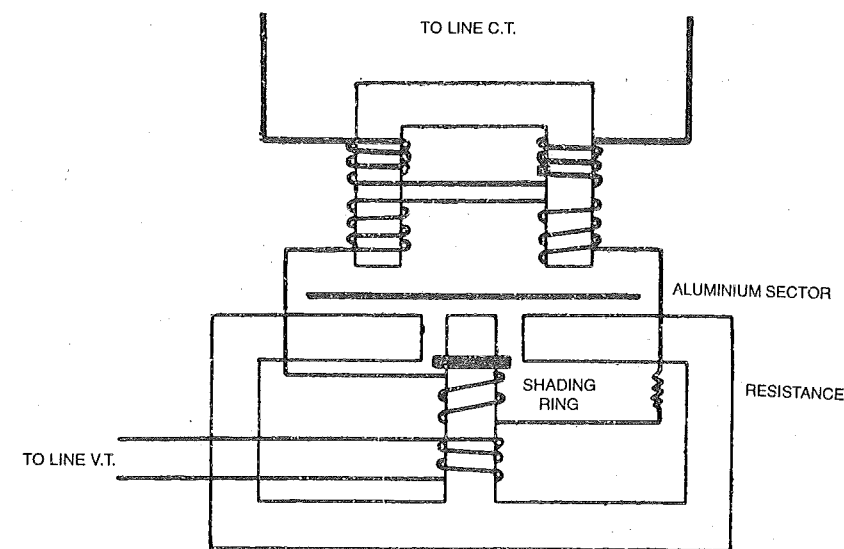

Fig. 26.21. (a). Vector diagram of Power.



Directional Element: Electro-magnetic System.

Fig. 26.21 (b). Directional relay induction disc type.

(direction) of power applied at their terminals. 'Directional relays' are used in protective system as elements which judge the direction of power flow.

Both Direction Power Relays and Directional Over-current, Directional Earth fault relays come under the group "Directional Relays". Induction disc type-watthour meter type constructional can be modified to obtained directional feature. When directional feature is desired, the relay is provided with two actuating coils called 'Current Coil' and 'Voltage Coil'. Fig. 26.21 illustrates the construction of an a.c. directional relay. Applications of directional relays have been discussed in Sec. 27.5.

Induction cup relays having 4, 6, 8 pole construction are also used as directional relays. The current coils of the relays are connected to the secondary of CT's (1 A, 5 A or 0.5 A). Voltage coils of directional relay are connected to the secondary of PT's. (110V). The method of connections is important. Depending upon the phase angle between current and voltage in the relay coils, the connection is called 90° , 60° , 30° connection. The values of angles refer to the phase angle between current of the current coil and voltage of the voltage coil. Fig. 26.22 explains the phase relationship of a 90° connected directional relay.

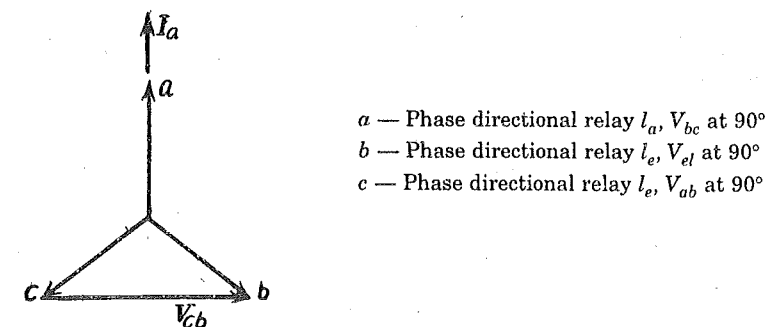

Fig. 26.22. 90° connection of directional relay : phase relationship.

Maximum torque angle of directional relay is the angle between current in the current coil and voltage applied to voltage coil to obtain maximum torque. Maximum torque angle has typical values such as 0° , 30° , lead 45° etc.

26.16.3. Principle of Operation of Directional Element

The moving system of induction disc type directional relay comprises an aluminium sector and a contact which are fixed to a vertical spindle fitted with hardened steel pivots. The hair spring,

which is attached to the spindle at one end and to the main frame at the other, is equipped with a torsion setting device and serves two purposes ; (a) as control spring and (b) as the electrical connection from the moving contact to the main frame.

Under healthy system conditions or, under fault conditions where the current flow is in the normal directional, eddy currents induced in the sector produce a torque the direction of which restrains relay operation. Should current reversal occur, then the direction of the torque reverse causing the moving system to rotate and thus close the contacts, the latter being so connected that they complete the I.D.M.T. element operating coil circuit.

The maximum torque exerted on the movement occurs when the voltage and current in the coils are in phase. However, as the system power factor may be considerably removed from unity under fault conditions, depending on both the nature of the fault and system conditions, the element can be supplied with a phase-angle suited to the particular application, *i.e.* the relay is arranged to develop maximum torque at the probable phase-angle introduced by fault conditions. This is achieved by employing a suitable shading ring, the requisite value of resistance and the appropriate connection.

26.17. POLARIZED MOVING IRON RELAYS

These are moving iron relays with an additional polarising feature. Polarising quantity is one that produces flux in addition to the main flux. A moving iron relay can be polarised by providing a permanent magnet in its magnetic circuit. Fig. 26.24 shows a polarized relay.

Polarization increases the sensitivity of the relay, the other features of the relay as combinations of speed, sensitivity, characteristics etc. can be modified by means of polarization.

26.18. FREQUENCY RELAYS*

The frequency of induced e.m.f. of synchronous generators is maintained constant by constant speed. In case of overspeeding due to loss of load, underspeeding due to increase in load etc. the frequency varies from normal value. Frequency relays are used in generator protection and for Load-frequency control. (Ref. Sec. 45.7)

Frequency relays are either electromagnetic or static. They can be under-frequency relays or over-frequency relays.

Frequency relays are generally connected to the secondary of voltage transformer. The frequency relay monitors the frequency continuously. It has two pairs of coils, constituting Ferraris Measuring System. The two pairs of coils are connected in parallel to the supply voltage through impedances. The impedances vary with frequency of supply. The impedances are tuned such that no torque is exerted on the cup-rotor at rated frequency. The torque exerted on the cup-rotor be clockwise or anticlockwise depending upon the frequency is higher or lower than the rated frequency.

The frequency setting can be varied by varying the position of sliding resistor. The pick-up sensitivity can be varied by adjusting the restraining spring.

The relay can operate on under-frequency or over-frequency. The under voltage relay is general-lay provided in conjunction with under frequency relay.

* Ref. Sec. 45.8 for static frequency relay, load-frequency control.

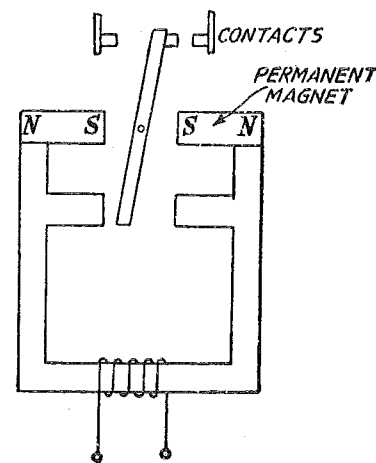

Fig. 26.23. Polarized Relay.

Technical Data of a Frequency Relay

— Rated voltage	100/110 V, $\pm 20\%$
— Scale	46 — 54 Hz
— Accuracy of set value	$\pm 0.4\%$
— Setting range for time lag	0.1 — 0.3 sec.
	0.1 — 0.5 sec.
	0.25 — 1 sec.
	1 — 5 sec.
— Consumption	12 VA

26.19. UNDER-VOLTAGE RELAYS

Under voltage protection is provided for A.C. Circuits, bus-bars, motors, rectifiers, transformers etc. such protection is given by means of Under-voltage relays. Under-voltage relays are necessary for voltage control and reactive power control of network buses and load buses. Undervoltage relays can have instantaneous characteristic or inverse characteristic depending upon the construction and design. Inverse time undervoltage relays have inverse characteristic, their operating time reduces with reduction in voltage. Induction disc type construction is used for Inverse undervoltage relay. The relay coil is energized by voltage to be measured either directly or *via* a voltage transformer.

The construction of instantaneous under-voltage relays is similar to usual induction relay or attached armature relay. But the directions of torque/forces on the movable element of relay are different. For normal voltage, the restraining torque/force reduces and the relay operates due to operating torque/force given by the spring.

Typical setting-range of an Inverse Undervoltage Relays :

- 50 to 90%, Adjustable in equal steps of 10%.
- For 240 V or 400
- Disc resets completely at 10% or lest of voltage setting.
- Inverse characteristic.
- Consumption 5 VA at setting voltage.

26.20. D.C. RELAYS

Induction disc type and Induction cup type constructions are not suitable for d.c. Moving iron type, permanent magnet moving coil type, thermal type constructions are employed for d.c. relays. Permanent magnet moving coil relays have relatively high accuracy. Low consumption and are, therefore, widely used for d.c. circuits. Static relays are being increasingly preferred for d.c. use. (Ref. Sec. 26.13).

Applications of D.C. Relays. D.C. relays are used in d.c. trolley-bus systems, motor control, electroplating works, chemical and metallurgical processes, auxiliary and control circuits.

D.C. current relays are developed for controlling direct current, *i.e.* either rise in current, or fall in current or reverse current. D.C. relays are also developed for current regulating, summation or differential operations.

D.C. voltage relays are generally suitable for control of d.c. voltage *i.e.* either rise in voltage or fall in voltage or reversal of voltage, special designs are available for regulating the voltage.

D.C. relays are used for a.c. applications in conjunction with rectifiers. These are called Rectifier Relays.

26.21. ALL-OR-NOTHING RELAYS

In 'All-or-nothing relays', the pick-up value is not critical. The relay does not perform precise measurement, but it does not operate and changes its state (open contacts, close contacts). All-or-nothing relays include tripping relays, repeat contactors, time-lag relays, trip circuit supervision

relays, auxiliary relays, indicator relays, etc. Such relays assist the measuring relays and they take over the various duties such as time lag, tripping indication etc. from the protective relay. Thereby, the protective relay can be designed for less burden and more sensitivity.

Repeat contactors are important components of relay contact systems. They repeat the operation of the measuring relay and relieve the latter of the duties such as carrying current for a longer period. Thus the contacts of the measuring relay are relieved of other tasks and they can be made of light weight, delicate resulting in higher sensitivity of relay and less burden.

Alarm relays initiate alarm. In many abnormal conditions such as overload, the tripping of essential service motors or equipment may not be desirable. In such cases alarm is provided. So that the operator is alerted and can take corrective action. Alarm : visual (lamps) and audible (bell).

Tripping relays are fast, instantaneous relays and are generally attracted armature type. They are either hand or electrically reset type. Their operating time is of the order of 10 ms. Tripping relays have a few pairs of robust contacts. Tripping relays are used for high speed tripping duties where a number of simultaneous switching operations are desired.

Flag indicator relays are used for obtained indications of the operation of a remote protective device. The operation of a relay indicates operation of the corresponding measuring relay and circuit-breaker.

26.22. PLUG SETTING (Ref. Sec. 26.11.1. and 26.11.2)

It should be possible to use the same relay for a certain range of current/voltage. Hence a plug setting bridge is provided with electromagnetic relays. The plug setting refers to the reference value of operating quantity at which the relay starts operating. If by inserting the plug, setting of 2.5 is selected, the relay will start operating when the current in relay coil (secondary current of (CT) is about 2.5 A or more. Fig. 26.12 illustrates the principle of plug setting. Plug setting determines the number of turns tapped from the relay coil. The current-time characteristic for various plug setting, is generally same, provided time setting remains unchanged. Such performance is achieved by matching the plug-setting and corresponding number of turns tapped from the coil such that the Ampere-turns remains same for various plug-settings.

26.23. TIME SETTING (Refer Fig. 26.14)

In induction disc relays, the starting position of the moving contact is adjusted by means of back-stop. The time taken by relay to close is decided by the length of arc through which the moving contact travels, before touching the fixed contacts.

By increasing the length of travel of moving contacts, the relay time is increased. By reducing the length of travel, the relay time is minimised. The time setting dial is marked from 1 to 0.1.

26.24. TEST FACILITY

It should be possible to test the relay by injection test without actually tripping the circuit breaker, *i.e.* without closing the trip circuit, or without disturbing the panel wiring. In flush mounted, withdrawable relays, the relay is mounted on a carriage which can be completely pulled

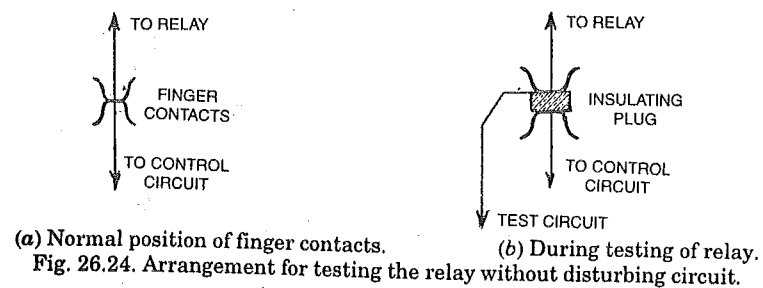

Fig. 26.24. Arrangement for testing the relay without disturbing circuit.

out the case for the purpose of testing keeping the connections undistributed. The terminals of current transformers are automatically short circuited. Such relays can be tested by inserting test plugs between finger contacts between the case and the carriage.

QUESTIONS

1. Define the following terms : Pick-up, reset.
2. With a neat sketch, describe the difference between definite characteristic and inverse characteristic of relays.
3. Describe the various types of constructions of attracted armature type relay. Why can they operate with a.c. and d.c.? State its salient features.
4. Describe the construction of an induction disc relay. State its principle of operation. What are the advantages to induction relays. How is the current setting and time setting obtained?
5. State the advantages and disadvantages of a moving coil permanent magnet relay. Can it be used for a.c. circuits? How?
6. State the application of thermal relays. Describe the principle of operations. Give a schematic diagram of automatic temperature control of a furnace.
7. Explain the principle of Directional Element. Where is it applicable?
8. What are Rectifier Relays? Explain the components.
9. Explain the principle, types and applications of thermal relay.

Overcurrent Protection and Earth Fault Protection

Introduction — Applications — Relay Units — Characteristics — Methods of CT Connections — Earth Protection — Directional Earth Fault Protection — Summary

27.1. INTRODUCTION

As the fault impedance is less than load impedance, the fault current is more than load current. If a short circuit occurs the circuit impedance is reduced to a low value and therefore a fault is accompanied by large current. Overcurrent relays sense fault currents and also over-load currents.

Overcurrent protection is that protection in which the relay picks up when the magnitude of current exceeds the pickup level. The basic element in overcurrent protection is an overcurrent relay.

The overcurrent relays are connected to the system, normally by means of CT's. Overcurrent relaying has following types :

- High speed overcurrent protection.
- Definite time overcurrent protection.
- Inverse minimum time overcurrent protection.
- Directional overcurrent protection (of above types).

Over-current protection includes the protection from overloads. This is most widely used protection. Overloading of a machine or equipment (generally) means the machine is taking more current than is rated current. Hence with overloading, there is an associated temperature rise. The permissible temperature rise has limit based on insulation class and material problems. Over-current protection of overloads is generally provided by thermal relays.

Over-current protection includes short-circuit protection. Short circuits can be phase faults, earth faults or winding faults. Short-circuit currents are generally several times (5 to 20) full load current.

Hence fast fault clearance is always desirable on short-circuits.

When a machine is protected by differential protection, the over-current is provided in addition as a back-up and in some cases to protect the machine from sustained through fault.

Several protective devices are used for over-current protection. These include

- Fuses
- Miniature circuit-breakers, moulded-case circuit-breakers.
- Circuit-breakers fitted with overloaded coils or tripped by over-current relays.
- Series connected trip coils operating switching devices.
- Over-current relays in conjunction with current transformers.

The primary requirements of over-current protection are :

- The protection should not operate for starting currents, permissible overcurrents, current surges. To achieve this, the time delay is provided (in case of inverse relays). If time delay cannot be permitted, high-set instantaneous relaying is used.
- The protection should be co-ordinated with neighbouring over-current protections so as to discriminate.

27.2. APPLICATIONS OF OVER-CURRENT PROTECTION

Over-current protection has a wide range of applications. It can be applied where there is an abrupt difference between fault current within the protected section and that outside the protected section and these magnitudes are almost constant. The over-current protection is provided for the following :

Motor Protection. Over-current protection is the basic type of protection used against overloads and short-circuits in stator windings of motors. Inverse time and instantaneous phase and ground over-current relays can be employed for motors above 1000 kW. For small/medium size motors where cost of CT's and protective relays is not economically justified, thermal relays and HRC fuses are employed, thermal relays used for overload protection and HRC fuses for short-circuit protection.

Transformer Protection. Transformers are provided with over-current protection against faults, only, when the cost of differential relaying cannot be justified. However, over-current relays are provided in addition to differential relays to take care of through faults. Temperature indicators and alarms are always provided for large transformers.

Small transformers below 500 kVA installed in distribution system are generally protected by drop-out fuses, as the cost of relays plus circuit-breakers is not generally justified.

Line Protection. The lines (feeders) can be protected by :

1. Instantaneous over-current relays.
2. Inverse time over-current relays.
3. Directional over-current relays.

Lines can be protected by impedance, or carrier current protection also.

Protection of Utility Equipment. The furnaces, industrial installations, commercial, industrial and domestic equipment are all provided with over-current protection.

27.3. RELAYS USED IN OVER-CURRENT PROTECTION

The choice of relay for over-current protection depends upon the time/current characteristic and other features desired. The following relays are used.

1. For instantaneous over-current protection.

Attracted armature type, moving iron type, permanent magnet moving coil type, static.

2. For inverse time characteristic.

Electromagnetic induction type, permanent magnet moving coil type, static.

3. Directional over-current protection.

Double actuating quantity induction relay with directional feature.

4. Static over-current relays. (Ref. Ch. 40)

5. HRC fuses, drop out fuses, etc. are used in low voltage medium voltage and high voltage distribution systems, generally up to 11 kV.

6. Thermal relays are used widely for over-current protection.

27.4. CHARACTERISTICS OF RELAY UNITS FOR OVER-CURRENT PROTECTION

There is a wide variety of relay-units. These are classified according to their type and characteristics. The major characteristic include :

- Definite characteristic
- Extremely Inverse
- Inverse
- Inverse characteristic
- Very Inverse

In definite characteristic, the time of operation is almost definite *i.e.*,

$$I^0 t = K$$

where I = Current in relay coil

t = Relay lime

K = Constant.

In inverse characteristic, time is inversely proportional to current *i.e.*

$$I^1 t K$$

In more inverse characteristic.

$$I^n t = K$$

where n can be between 2 to 8. The choice depends on discrimination desired.

Instantaneous relay are those which have no intentional time lag and which operate in less than 0.1 second, usually less than 0.08 second. As such they are not instantaneous in real sense.

The relays which are not instantaneous are called 'Time Delay Relay'. Such relays are provided with delaying means such as drag magnet, dash pots, bellows, escape mechanisms, back-stop arrangement, etc.

The operating time of a relay for a particular setting and magnitude actuating quantity can be known from the characteristics supplied by the manufacturer. The typical characteristics are shown in Fig. 26.14.

An inverse curve is one in which the operating time; becomes less as the magnitude of the actuating quantity is increased. However for higher magnitudes of actuating quantity the time is constant. Definite time curve is one in which operating time is little affected by magnitude of actuating current. However even definite time relay has a characteristic which is slightly inverse.

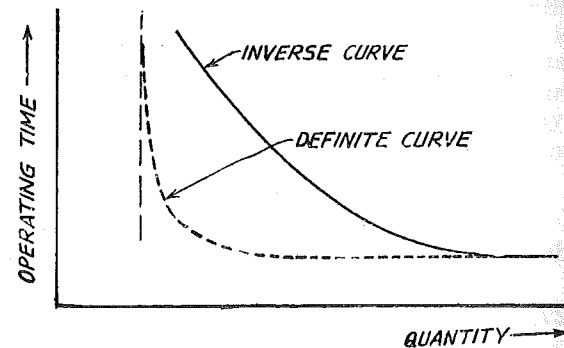

Fig. 27.1. Typical curves of operating time vs magnitude of actuating quantity.

The characteristic with definite minimum time and of inverse type is also called Inverse Definite Minimum Time (IDMT); characteristics (Ref. Fig. 26.14 also).

Methods of Ct Connections in Over-current Protection of 3-Phase Circuits.

27.4.1. Connection Scheme with Three Over-current Relays

Over-current protection can be achieved by means of three over-current relays (Fig. 27.2) or by two over-current relays (Fig. 27.3). Ref. Sec. 26.2 for principle of Trip Circuit.

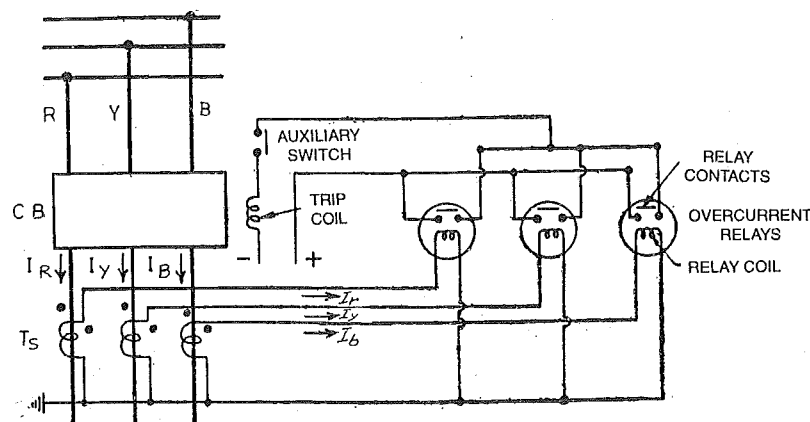

Fig. 27.2. Over-current protection with three over-current relays.

Referring to Fig. 27.2 the three current transformers and relay coils connected in star and the star point is earthed. When short circuit occurs in the protected zone the secondary current of CT's increases. The current flows through coiler and the relay picks-up. The relay close, thereby the trip circuit is closed and the circuit breaker-operates.

The over-current protection scheme with three over-current relays (Fig. 27.2) responds to phase faults and earth faults including single-phase to earth fault. Therefore such schemes are used with solidly earthed systems where phase to phase and phase to earth faults are likely to occur.

In Fig. 27.2 the polarities of CT's are indicated by dots. For proper functioning of over-current and earth fault protection, the choice of CT's and polarity connections should be correct.

Fig. 27.3 illustrates the modified circuit with additional auxiliary relay and a definite time relay. Definite time relay can be set to get desired delay. Auxiliary relay is used to close trip circuit.

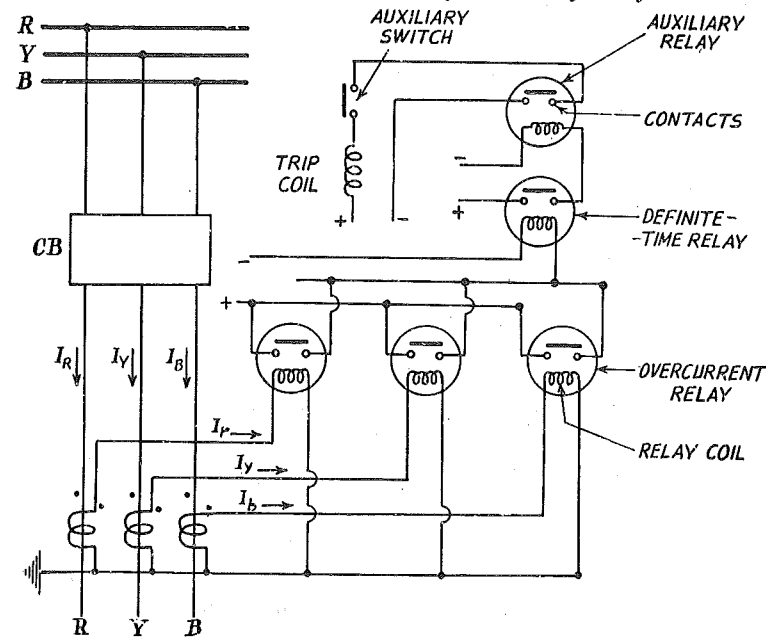

Fig. 27.3. Circuit of Fig. 27.2 with addition of a common time-delay relay and an auxiliary relay.

27.5. EARTH-FAULT PROTECTION

(Called Ground protection in USA)

When the fault current flows through earth return path, the fault is called *Earth Fault*. Other faults which do not involve earth are called *phase faults*. Since earth faults are relatively frequent, earth fault protection is necessary in most cases. When separate earth fault protection is not economical, the phase relays sense the earth fault currents. However such protection lacks sensitivity. Hence separate earth fault protection is generally provided. Earth fault protection senses earth fault current. Following are the method of earth fault protection.

27.6. CONNECTIONS OF CT'S FOR EARTH-FAULT PROTECTION

27.6.1. Residually connected Earth-fault Relay

Referring to Fig. 27.7.

In absence of earth-fault the vector sum of three line currents is zero.

Hence the vector sum of three secondary currents is also zero.

$$\bar{I}_{as} + \bar{I}_{bs} + \bar{I}_{cs} = 0$$

The sum ($\bar{I}_{as} + \bar{I}_{bs} + \bar{I}_{cs}$) is called residual current (I_{RS})

The earth-fault relay is connected such that the residual current flows through it (Ref. Figs. 27.7 and 27.9).

In the absence of earth-fault,

$$\bar{I}_{residual} = \bar{I}_{as} + \bar{I}_{bs} + \bar{I}_{cs} = 0$$

Therefore, the residually connected earth-fault relay does not operate. However, in presence of earth fault the conditions is disturbed and ($\bar{I}_{as} + \bar{I}_{bs} + \bar{I}_{cs}$) is no more zero. Hence residual $I_{residual}$ flows through the earth-fault relay. If the residual current is above the pick-up value, the earth-fault relay operates.

In the scheme discussed here the earth-fault at any location near or away from the location of CT's can cause the residual current flow. Hence the protection zone is not definite. Such protection is called unrestricted earth-fault protection. For selectivity directional earth fault protection is necessary. (Ref. Sec. 27.12).

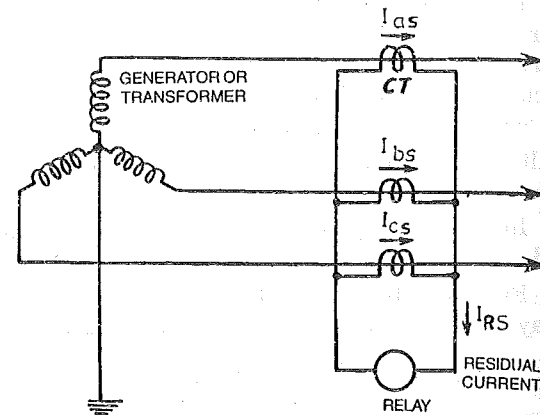

Fig. 27.7. Earth-fault Relay connected in Residual Circuit.

	Connection	Description	Remarks
(1)		One OC with one CT for overload protection	For balanced overloads only.
(2)		Two OC relays with two CT's for line to line fault protection and overload protection.	CT's must be in same phase in every station.
(3)		Three OC relays with three CT's for line to line fault protection	Earth fault protection for EF current > 2 x pick-up phase current.
(4)		Three OC and one EF relay for line to earth fault protection and line to line fault protection	EF setting less than phase fault setting.
(5)		Two OC and one EF relays for line to line earth fault protection	EF setting less than full load. (Ref. Fig. 27.10)
(6)		One EF relay with core balance CT	EF setting less than full load. (Ref. Fig. 27.11)

OC = Overcurrent ; EF = Earth fault.
Fig. 27.4. Methods of connections of OC and EF Relays.

27.6.2. Earth-fault Relay connected in Neutral to Earth Circuit (Fig. 27.8).

Another method of connecting an earth-fault relay is illustrated in Fig. 27.8. The relay is connected to secondary of a CT whose primary is connected in neutral to earth connection. Such protection can be provided at various voltage levels by connecting earth-fault relay in the neutral-to-earth

connection of that voltage level. The fault current finds the return path through the earth and then flows through the neutral-to-earth connection. The magnitude of earth fault current is dependent on type of earthing (resistance, reactance or solid) and location of fault. In this type of protection, the zone of protection cannot be accurately defined. The protected area is not restricted to the transformer/generator winding alone. The relay senses the earth faults beyond the transformer/generator winding. Hence such protection is called unrestricted earth-fault protection.

The earth-fault protection by relay in neutral to earth circuit depends upon the type of neutral earthing. In case of large generators, voltage transformer is connected between neutral and earth. The earth-fault relay is connected to Secondary of VT. (Fig. 33.11)

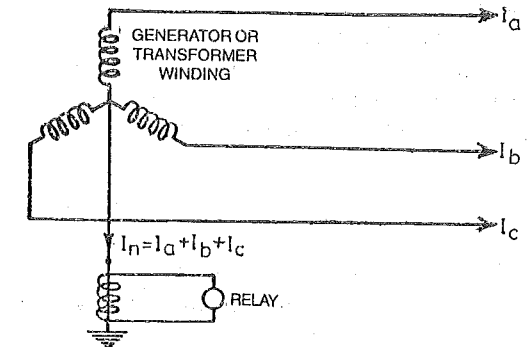

Fig. 27.8. Earth-fault protection by earth-fault-relay connected in neutral-to-earth circuit.

27.7. COMBINED EARTH-FAULT AND PHASE-FAULT PROTECTION

It is convenient to incorporate phase-fault relays and earth-fault relay in a combined phase-fault and earth-fault protection. (Fig. 27.9). The increase in current of phase causes corresponding increase in respective secondary currents. The secondary current flows through respective relay-units. Very often only two phase relays are provided instead of three, because in cause of phase faults current in any at least two phases must increase. Hence two relay-units are enough. The earth-fault relay is residually connected as explained earlier. [Ref. Fig. 35.4 (b) in Sec. 35.8]

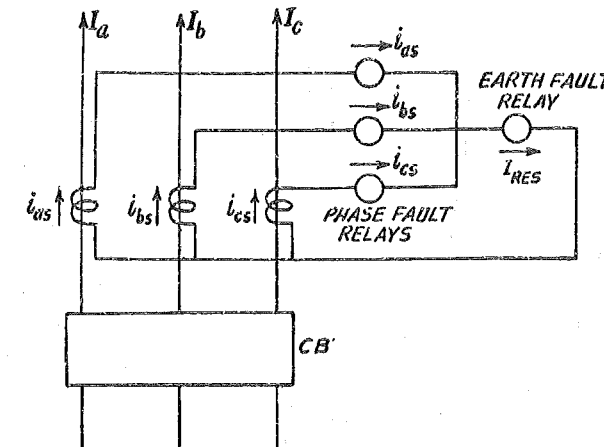

Fig. 27.9. Earth-fault protection combined with phase-fault protection. [Ref. Fig. 35.4 (b)]

27.8. EARTH-FAULT PROTECTION WITH CORE BALANCE CURRENT TRANSFORMERS. (ZERO SEQUENCE CT)

In this type of protection Fig. 27.10 (a) a single ring shaped core of magnetic material, encircles the conductors of all the three phases. A secondary coil is connected to a relay unit. The cross-section of ring-core is ample, so that saturation is not a problem. During no-earth-fault condition, the components of fluxes due to the fields of three conductors are balanced and the secondary current is negligible. During earth faults, such a balance is disturbed and current is inducted in the secondary. Core-balance protection can be conveniently used for protection of low-voltage and medium voltage

systems. The burden of relay and exciting current are deciding factors. Very large cross-section of core are necessary for sensitivity less than 1 A. Thus form of protection is likely to be more popular with static relays due to the less burden of the latter. Instantaneous relay unit is generally used with core balance schemes.

Theory of Core Balance CT. Let \bar{I}_a, \bar{I}_b and \bar{I}_c be the three line currents and $\bar{\phi}_a, \bar{\phi}_b$ and $\bar{\phi}_c$ be corresponding components of magnetic flux in the core. Assuming linearity, we get resultant magnetic flux $\bar{\phi}_r$ as,

$$\bar{\phi}_r = k (\bar{I}_a + \bar{I}_b + \bar{I}_c)$$

where k is constant $\bar{\phi}_r = k I_a$. Referring to theory of symmetrical components (Ref. Ch. 21, Sec. 21.5)

$$\bar{I}_a + \bar{I}_b + \bar{I}_c = 3\bar{I}_0 = \bar{I}_n$$

where, I_0 is zero sequence current and I_n is current in neutral to ground circuit.

During normal condition, when earth fault is absent,

$$\bar{I}_a + \bar{I}_b + \bar{I}_c = 0$$

Hence $\bar{\phi}_r = 0$ and relay does not operate

During earth fault the earth fault current flows through return neutral path. For example for single line ground fault,

$$I_f = 3I_{a0} = I_n$$

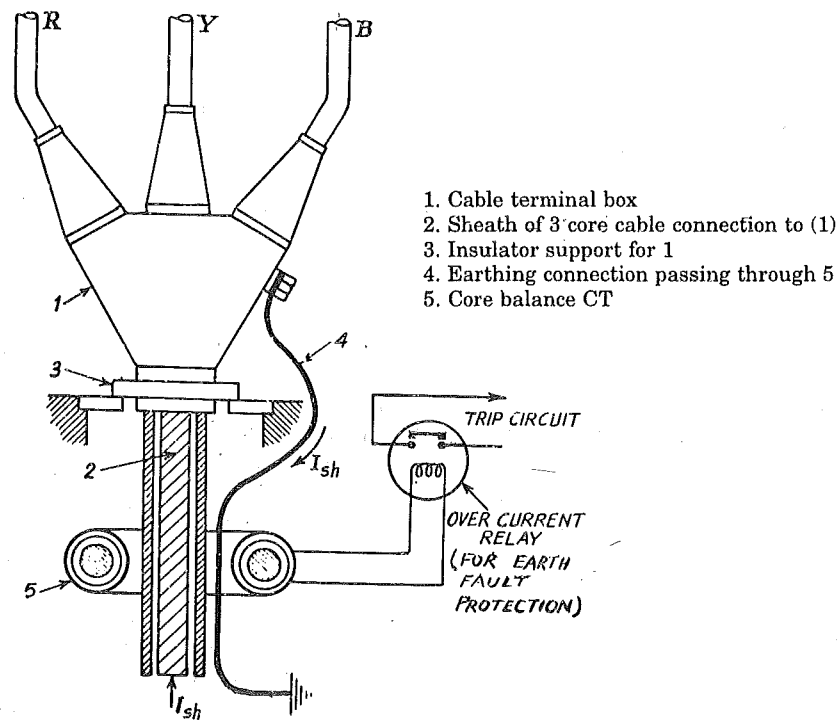
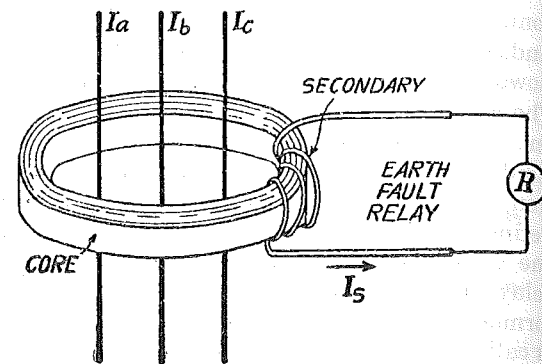

Fig. 27.10 (b). Mounting of Core Balance CT with Cable Terminal Box.



[I_s flows when there is an earth-fault and $I_a + I_b + I_c \neq 0$]
Fig. 27.10 (a). Principle of core-balance CT for earth fault protection.

Hence the zero-sequence component of I_0 produces the resultant $\bar{\phi}_r$ in the core. Hence core balance current transformer is also called as zero sequence current transformer (ZSCT).

Application for Core Balance CT's with Cable Termination Joints

The termination of a three core cable into three separate lines or bus-bars is through cable terminal box. Ref. Fig. 27.10 (b), the Core Balance Protection is used along with the cable box and should be installed before making the cable joint.

The induced current flowing through cable sheath of normal healthy cable need particular attention with respect to the core balance protection.

The sheath currents (I_{sh}) flow through the sheath to the cover cable-box and then to earth through the earthing connection between cable-box. For eliminating the error due to sheath current (I_{sh}) the earthing lead between the cable-box and the earth should be taken through the core of the core balance protection. Thereby the error due to sheath currents is eliminated. The cable box should be insulated from earth. (Ref. Sec. 31.11 also).

27.9. FRAME-LEAKAGE PROTECTION

The metal-clad switchgear can be provided with frame leakage protection. The switchgear is lightly insulated from the earth. The metal-frame-work or enclosure of the switchgear is earthed with a primary of a CT in between (Fig. 27.11).

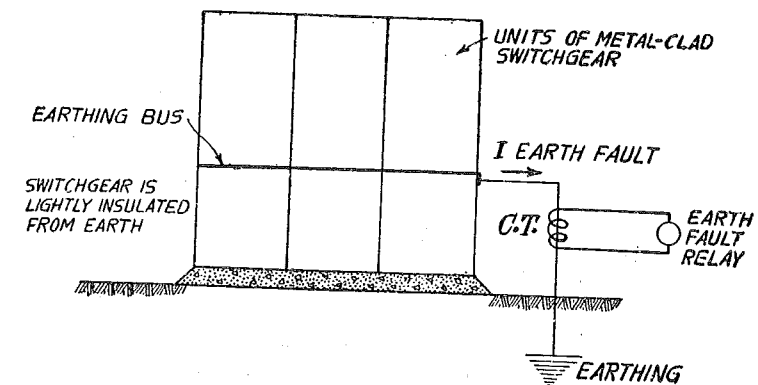

Fig. 27.11. Principle of frame-leakage protection of metal-clad-switchgear.

The concrete foundation of the switchgear and the cable-boxes and other conduits are slightly insulated from earth, the resistance to earth being about 12 ohms. In the event of an earth fault within the switchgear, the earth-fault current finds the path through the neutral connection. While doing so, it is sensed by the earth fault relay.

Circulating current differential protection also responds to earth-faults within its protected zone.

Summary

Earth-fault protection can be achieved by following methods :

- Residually connected relay
- Relay connected in neutral-to-ground circuit
- Core-balance-scheme
- Frame leakage arranged for detecting earth faults on lines. (Ref. Ch. 30).
- Circulating current differential protection. (Ref. Ch. 28).

27.10. DIRECTIONAL OVER-CURRENT PROTECTION

The over-current protection can be given directional feature by adding directional element (Ref. Sec. 26.16.2) in the protection system. Directional over-current protection responds to overcurrents for a particular direction flow. If power flow is in the opposite direction, the directional over-current protection remains un-operative.

Directional over-current protection comprises over-current relay and power directional relay in a single relay casing. The power directional relay does not measure the power but is arranged to respond to the direction of power flow. (Ref. Fig. 26.21 b).

Directional operation of relay is used where the selectivity can be achieved by directional relaying. The directional relay recognizes the direction in which fault occurs, relative to the location of the relay. It is set such that it actuates for faults occurring in one direction only. It does not act for faults occurring in the other direction. Consider a feeder XY (Fig. 27.12) passing through sub-section A. The circuit breaker in feeder AY is provided with a directional relay 'R' which will trip the breaker CB_y , if fault power flow in direction A, alone. Therefore for faults in feeder AX, the circuit breaker CB_y does not trip unnecessarily. However for faults in feeder A, the circuit-breaker CB_y trips because its protective relaying is set with a directional feature to act in direction A.

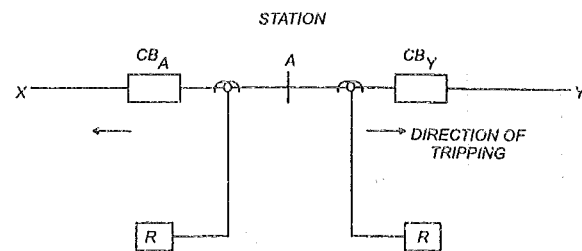

Fig. 27.12. Principle of directional protection.

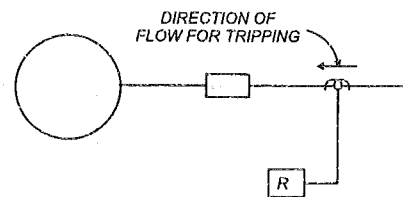

Fig. 27.13. Reverse power protection against motoring action of a generator.

Another interesting example of directional protection is that of **reverse power protection** of generator (Fig. 27.13). If the prime mover fails, the generator continues to run as a motor and takes power from bus-bars. (Ref. Ch. 28).

Directional power protection operates in accordance with the direction of power flow. (Ref. Sec. 26.15).

Reverse power protection operates when the power direction is reversed in relation to the normal power flow. Reverse power relay is different in construction than directional over-current relay.

In directional over-current relay, the directional current does not measure the magnitude of power. It senses only direction of power flow. However, in Reverse Power Relays, the directional element measures magnitude and direction of power flow.

Relay connections of Single Phase Directional Over-current Relay :

The current coils in the directional over-current relay (Ref. Fig. 26.21 b) are normally connected to a secondary of line CT. The voltage coil of directional element is connected to a line VT, having phase to phase output (of 110 V). There are four common methods of connecting the relay depending upon phase angle between current in the current coil and voltage applied to the voltage coil.

Relay Connection. (e.g. 90° , 60° , 30° etc) refer to the angle by which the current applied to the relay is displaced from the voltage applied to the relay. (Ref. Fig. 26.22).

The maximum torque angle refers to the angle between the current applied to the relay and the voltage applied to the relay to produce maximum torque.

The choice of relay connection is basically to select the phase across which the voltage coil is connected with respect to current coil. Number of different connections can be used. The suitability of each connection should be examined by considering the limiting conditions of voltage and current for limiting fault conditions, source and line impedances etc.

27.11. DIRECTIONAL EARTH-FAULT PROTECTION

In the directional over-current protection the current coil of relay is actuated from secondary current of line CT. Whereas the current coil of directional earth fault relay is actuated by residual current.

In directional over-current relay, the voltage coil is actuated by secondary of line VT. In directional earth fault relay, the voltage coil is actuated by the residual voltage.

Directional earth fault relays sense the direction in which earth fault occurs with respect to the relay location; and it operates for fault in a particular direction. The directional earth fault relay (single phase unit) has two coils. The polarising quantity is obtained either from residual current ($\bar{I}_{RS} = \bar{I}_a + \bar{I}_b + \bar{I}_c$) or residual voltage ($\bar{V}_{RS} = \bar{V}_{ae} + \bar{V}_{bc} + \bar{V}_{ce}$, where V_{ae} , V_{be} , V_{ce} are phase voltages.)

Referring to Fig. 27.14 the directional earth-fault relay has two coils. One to the coils is connected in residual current circuits (Ref. Fig. 27.8). This coil gets current earth-faults. The other coil gets residual voltage,

$$\bar{V}_{RS} = \bar{V}_{ae} + \bar{V}_{be} + \bar{V}_{ce}$$

where \bar{V}_{ae} , \bar{V}_{be} and \bar{V}_{ce} are secondary voltages of the potential transformer. (Three phase five limb potential transformer or three separate single phase potential transformers connected as shown in Fig. 27.14). The coil connected in potential-transformer secondary circuit gives a polarising field.

The residual current I_{RES} i.e. the out of balance current is given to the current coil and the residual voltage V_{RES} is given to the voltage coil of the relay. The torque is proportional to

$$T = I_{RES} V_{RES} \cos(\phi - \alpha)$$

$$\phi = \text{angle between } I_{RES}, V_{RES}$$

$$\alpha = \text{Angle of maximum torque.}$$

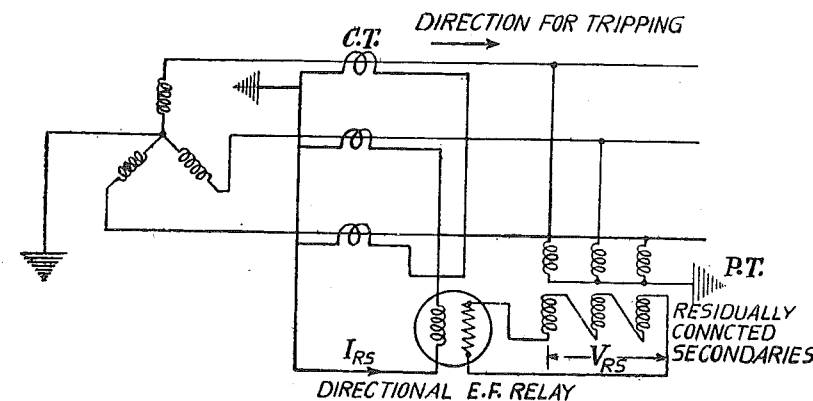

Fig. 27.14. Connections of a directional earth-fault relay.

Summary

Over-current protection responds to increase above the pick-up value overcurrents are caused by overloads and short-circuits. The overcurrent relays are connected the secondary of current

transformer. The characteristic of over-current relays include inverse time characteristic, definite time characteristic.

Earth fault protection responds to single line to ground faults and double line to ground faults. The current coil of earth-fault relay is connected either in neutral to ground circuit or in residually connected secondary CT circuit.

Core balance CTs are used for earth-fault protection.

Frame leakage protection can be used for metalclad switchgear.

Directional over-current relay and directional Earth fault relay responds to fault in which power flow is in the set direction from the CT and PT locations. Such directional relays are used when power can flow from both directions to the fault point.

QUESTIONS

1. State the various applications of over-current relaying. Distinguish between "inverse characteristics" and "definite characteristic".
2. With the help of neat sketches explain the principle of following:
 - (a) Directional Over-current protection.
 - (b) Earth fault protection by residual connection.
3. Describe Directional earth fault protection.
4. Discuss the following methods of earth fault protection :

— Core balance CT	— Residually connected E.F. relay
— Relay connected in neutral-to-ground circuit	— Frame leakage protection.
5. Describe the principle of a directional over-current relay. How does it help in discrimination in protection of

— parallel feeder	— ring mains.
-------------------	---------------
6. Explain the back-up relaying with graded time lag over-current relays.
7. Explain the time-setting and plug-setting in an induction type overcurrent relay.

Differential Protection

Differential protection — Applications — Circulating Current Differential Protection — Differential protection of 3 Ph. circuits — Biased Differential Relay — Balanced Voltage Differential Protection — Summary.

28.1. DIFFERENTIAL PROTECTION

"A differential relay responds to vector difference between two or more similar electrical quantities".

From this definition the following aspects are known :

1. The differential relay has at least two actuating quantities say I_1, I_2 .
2. The two or more actuating quantities should be similar *i.e.* current/current.
3. The relay responds to the vector difference between the two *i.e.* to $I_1 - I_2$, which includes magnitude and/or phase angle difference.

Differential protection is generally unit protection. The protected zone is exactly determined by location of CT's or VTs. The vector difference is achieved by suitable connections of current transformer or voltage transformer secondaries.

28.2. APPLICATIONS OF DIFFERENTIAL PROTECTION

Most differential relays are current differential relays in which vector difference between the current entering the winding and current leaving the winding is used for sensing and relay operation.

Differential protection principle is used in the following applications

- Protection of Generator, Protection of Generator-Transformer Unit.
- Protection of Transformer.
- Protection of Feeder (Transmission Line) by Pilot wire differential protection.
- Protection of transmission Line by Phase Comparison Carrier Current Protection.
- Protection of large motors.
- Bus-zone protection.

28.3. PRINCIPLE OF CIRCULATING CURRENT DIFFERENTIAL (MERZ-PRIZE) PROTECTION

Fig. 28.1 (a) illustrates the principle of differential protection of generator and transformer. X is the winding of the protected machine. When there is no internal fault, the current entering in X is equal in phase and magnitude to current leaving X. The CT's are of such a ratio that during the normal conditions or for external faults (Through Faults) the secondary currents of CT's are equal. These currents say I_1 and I_2 circulate in the pilot wires. The polarity connections are such that the currents I_1 and I_2 are in the same direction in pilot wires, during normal conditions or

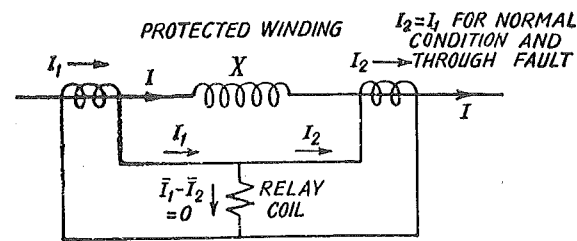

For Through Fault
Fig. 28.1 (a). Principle of circulating current relay of generators, transformers.

external faults. Relay operating coil is connected at the middle of pilot wires. Relay unit is of over-current type.

During normal condition and external fault the protection system is balanced and the CT's ratios are such that secondary currents are equal. These currents circulate in pilot wires. The vector differential current $I_1 - I_2$ which flows through the relay coil is zero.

$$I_1 - I_2 = 0 \text{ (normal condition or external faults)}$$

This balance is disturbed for internal faults. When fault occurs in the protected zone, the current entering the protected winding is no more equal to the leaving the winding because some current flows to the fault. The differential $I_1 - I_2$ flows through the relay operating coil and the relay operates if the operating torque is more than restraining torque.

The currents I_1 and I_2 circulate in the secondary circuit. Hence CT's does not get damaged. Polarities of CT's are considered. CT's are connected such that the circulating currents I_1 and I_2 are as shown in Fig. 28.1 (a) for normal condition.

28.4. DIFFICULTIES IN DIFFERENTIAL PROTECTION

1. **Difference in pilot wire lengths.** The current transformers and machine to be protected are located at different sites and normally it is not possible to connect the relay coil to the equipotential points. The difficulty is overcome by connecting adjustable resistors in series with the pilot wires. These are adjusted on site to obtain the equipotential points.

2. **CT Ratio errors during short-circuits.** The current transformer may have almost equal ratio at normal currents. But during short-circuit conditions, the primary currents are unduly large. The ratio errors of CT's on either sides differ during these conditions due to :

(i) Inherent difference in CT characteristic arising out of difference in magnetic circuit, saturation conditions etc.

(ii) Unequal d.c. components in the short circuit-currents.

3. **Saturation of CT magnetic circuits during short circuit condition.** Due to these causes the relay may operate even for external faults. The relay may lose its stability for through faults.

To overcome this difficulty, the *Percentage Differential Relay*, or '*Based Differential Relay*' is used. It is essentially a circulating current differential relay with additional restraining coil. The current flowing in restraining coil is proportional to $(I_1 + I_2)/2$ and this restraining current prevents the operation during external faults. Because, with the rise in current, the restraining torque increases and $I_1 - I_2$ arising out of difference in CT ratio is not enough to cause the relay operation. (Ref. Sec. 28.6).

4. **Magnetizing Current Inrush in transformer while switching in.** When the transformer is connected to supply, a large (6 to 10 times full load) current inrush takes place. This certainly causes operation of differential relay current inrush takes place. This certainly causes

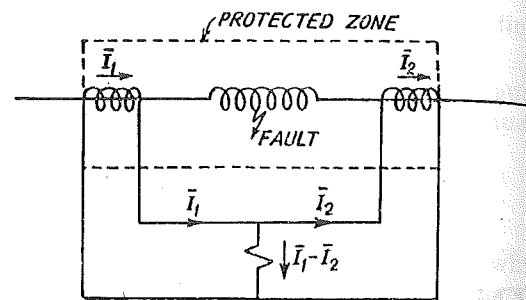

Fig. 28.1 (b). Internal Fault : $I_1 - I_2 \neq 0$.

operation of differential relay though there is no fault in the transformer. To avoid this difficulty *Harmonic Restraint* is provided for the differential relay. This relay filters the harmonic component from the in-rush current and feeds it to the restraining coil. The magnetizing current contains a large content of several Harmonics. This harmonic content is used for obtaining restraining torque during switching in of transformer.

5. **Tap-changing.** The tap-changing causes change in transformation ratio of a transformer. Thereby the CT ratios do not match with the new-tap settings, resulting in current in pilot wires even during healthy condition. This aspect is taken care of by biased differential relay.

28.5. DIFFERENTIAL PROTECTION OF 3-PHASE CIRCUITS

Referring to Fig. 28.2 during the normal conditions the three secondary currents of CT's are balanced and no current flows through the relay coil. During fault in the protected zone, the balance is disturbed and differential current flows through the relay operating coil. The differential current is above the pick-up value, the relay operates. (Ref. Sec. 27.6A).

Secondary of CT is never left on-open circuit.

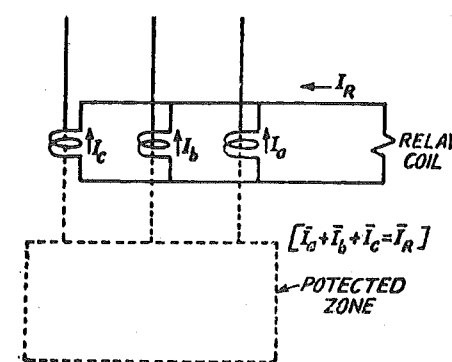

Fig. 28.2. Differential Protection of 3-phase circuit.

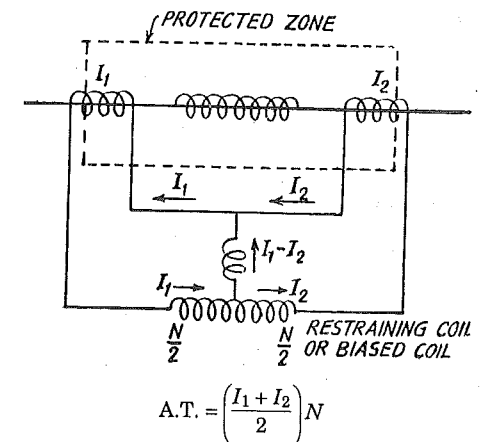

Fig. 28.3. Per cent Differential Relay. (Biased Differential Relay.)

28.6. BIASED OR PER CENT DIFFERENTIAL RELAY

The reason for using this modification is circulating current differential relay is to overcome the trouble arising out of differences in CT ratios for high values of external short-circuit currents. (Refer the previous paragraph). The percentage differential relay has an additional restraining coil connected in the pilot wire as shown in Fig. 28.3.

In this relay the operating coil is connected to the mid-point of the restraining coil. The total number of ampere turns in the restraining coil becomes the sum of ampere turns in its two halves, i.e. $\frac{I_1 N}{2} + \frac{I_2 N}{2}$ which gives the average restraining current of $\frac{I_1 + I_2}{2}$ in N turns. For external faults both I_1 and I_2 increase and thereby the restraining torque increases which prevents the mal-operation.

The operating characteristic of such a relay is given in Fig. 28.4.

The ratio of differential operating current to average restraining current is Fixed Percentage. Hence the relay is called '*Percentage Differential Relay*'.

The relay is also called '*Based Differential Relay*' because the restraining coil is also called a biased coil as it provides additional flux.

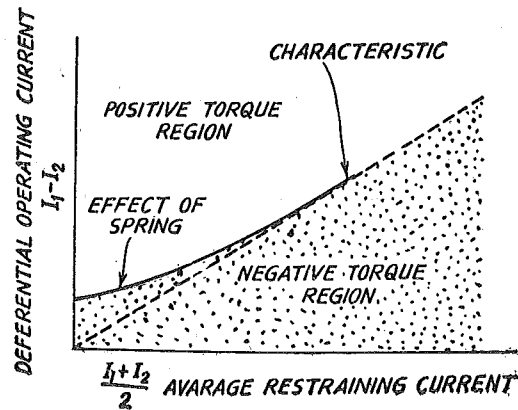

Fig. 28.4. Operating characteristic of differential relay.

The percentage of biased differential relay has a rising pick-up characteristic. As the magnitude of through current increases, the restraining current increases.

28.7. SETTINGS OF DIFFERENTIAL RELAYS

The circulating current differential relay has two principle settings namely,

- Setting of operating coil circuit
- Setting of restraining coil circuit.

Setting of Operating Coil Circuit (Basing setting). The percentage setting of (Basic Setting) of operating coil circuit is defined as the ratio:

$$\% \text{Basic Setting} = \frac{\text{Smallest current in operating coil to cause operation}}{\text{Rated current of the operating coil}} \times 100$$

(when the current in restraining coil is zero)

Setting of Operating Coil Circuit (Pick-up Value). It is defined as the ratio:

$$= \frac{\text{Current in operating coil for causing operation}}{\text{Current in restraining coil}} \times 100$$

$$\% \text{Pick-up Value} = \frac{I_1 - I_2}{(I_1 + I_2)/2} \times 100$$

While determining this setting the factors to be considered include

- CT errors
- Resistance of pilot wires
- Tap-changing
- Stability for through faults.

In case of power transformers, percentage basic setting is of the order of 20% and percentage Pick-up Value is of the order of 25%.

28.8. BALANCED VOLTAGE DIFFERENTIAL PROTECTION

Fig. 28.5 illustrates the principle of differential protection based on balanced voltage principle. In this system the secondaries of CT's are connected such that for normal conditions and through fault conditions, the secondary currents of CT's on two sides oppose each other and their voltage are balanced [Fig. 28.5 (a)]. During internal fault, the condition changes as illustrated in Fig. 28.5 (b) and an equivalent current $(I_1 + I_2)/2$ flows through relay coils at each end.

The current transformers used in such protection are with air gap core so that the core does not get saturated and overvoltages are not produced during zero secondary current under working normal condition.

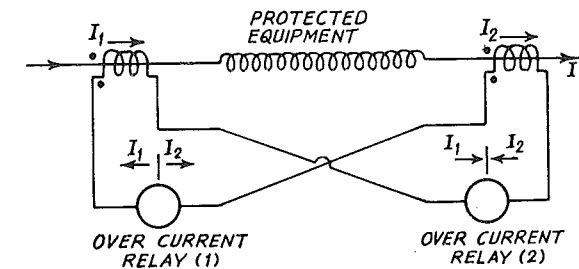

Fig. 28.5 (a). Through fault condition Differential Protection based on balanced voltage principle.

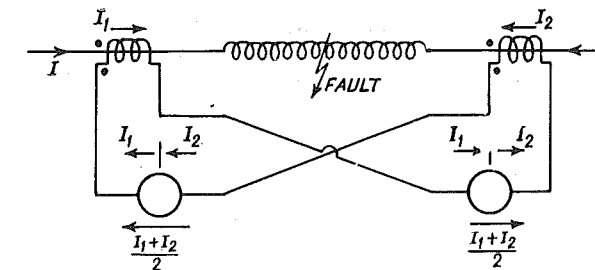

Fig. 28.5 (b). Internal fault condition.

QUESTIONS

1. Define 'Differential protection'. Describe the principle of circulating current differential protection.
2. Draw neat sketches illustrating the principle of circulating current differential protection. Indicate polarities of CT's and direction of currents for internal faults.
3. State the difference between Circulating Current Differential Protection and Balanced Voltage Differential Protection with reference to behaviour of CT's.
4. Explain the 'Differential Protection'. State the various applications of differential protection.

Distance Protection

Introduction — Principle of R-X Diagram — Theory — Impedance Relay — Time — Direction Impedance Relay — Mho type Admittance Type Distance Relays — Distance Protection schemes — Applications — 3 step Characteristics Coordination — Method of Analysis — Load Impedance — Power Swings — Various Characteristic Shapes.

29.1. INTRODUCTION TO DISTANCE PROTECTION

Distance relays are double actuating quantity relays with one coil energized by voltage and the other coil energized by current (Ref. Fig 29.1). The torque produced is such that when V/I reduces below a set value, the relay operates. During a fault on a transmission line the fault current increases and the voltage at fault point reduces. The ratio V/I is measured at the location of CT's and VT's. The voltage at VT location depends on the distance between the VT and the fault. If fault is nearer, measured voltage is lesser. If fault is further, measured voltage is more. Hence assuming constant fault resistance each value of V/I measured from relay location corresponds to distance between the relying point and the fault along the line. Hence such protection is called *Impedance Protection or Distance Protection*.

Distance protection is *non-unit* type protection, the protection zone is not exact. The distance protection is high speed protection and is simple to apply. It can be used as a primary and back-up protection. It can be used in Carrier Aided Distance Schemes and in Autoreclosing Schemes. Distance protection is very widely used in protection of transmission lines.

29.2. PRINCIPLE OF R-X DIAGRAM

R-X diagrams are useful in plotting characteristics of Distance Relays.

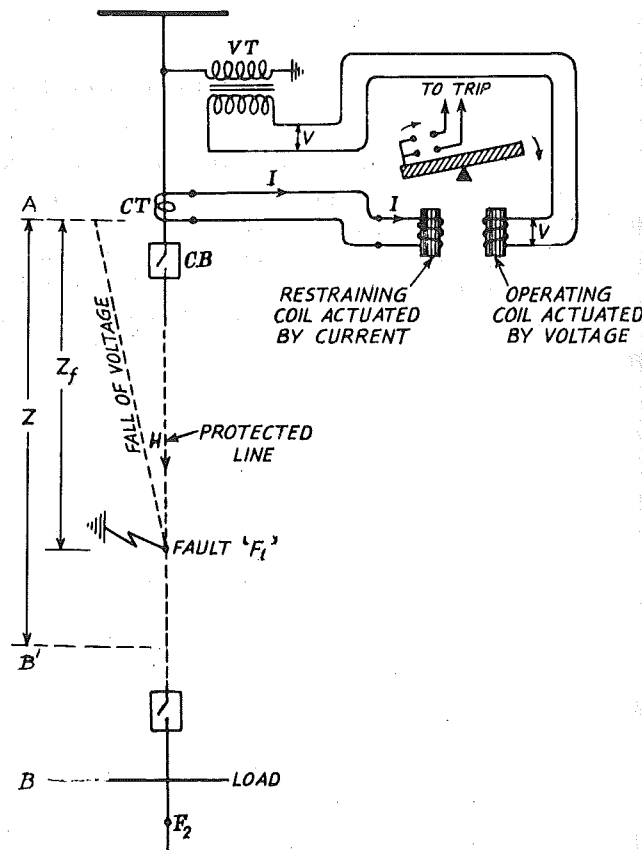

Fig. 29.1. Explaining Distance Protection.

The three variables V, I and ϕ are converted into two variables R and X . Impedance Z_1 is defined as ratio of r.m.s values of V and I , i.e.

$$|Z_1| = \frac{|V_1|}{|I_1|}$$

Z can be plotted on R-X diagram. (Ref. Fig. 29.2).

$$R_1 = Z_1 \cos \phi ; X_1 = Z_1 \sin \phi$$

ϕ is positive if I_2 lags V_1 , ϕ is negative if I_1 leads V_1 .

Thus V_1, I_1 and ϕ can be converted on R-X diagram as shown in Fig. 29.2.

The family of impedance relays (Distance Relays) can offer wide range of characteristics.

The basic principle should be understood and needs clear explanation.

Relays which measure plain impedance (Z) are called impedance relays. Their characteristic on R-X plane is a circle with centre as origin and radius as Z , Fig. 29.2.

Relays which measure impedance but respond to faults on one direction only are called directional impedance relay. Their characteristic on R-X plane is a semi-circle on an inclined line. The centre of semi-circle is at centre of R-X diagram.

Relays having voltage restraint in addition to directional and impedance elements have a circular characteristic on R-X diagram but with centre shifted from origin.

Mho-relays have a circular characteristic, the circumference of the circle passes through the origin.

The detail explanation about these characteristics has been given below.

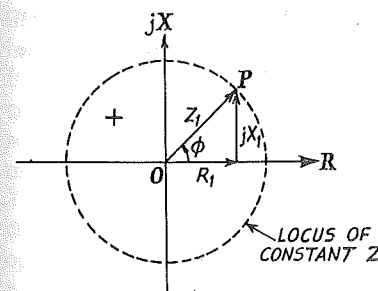
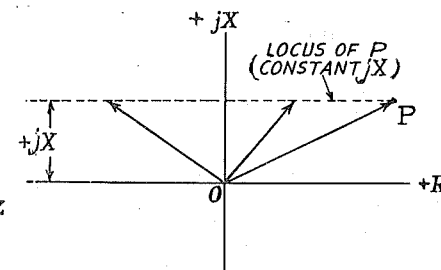
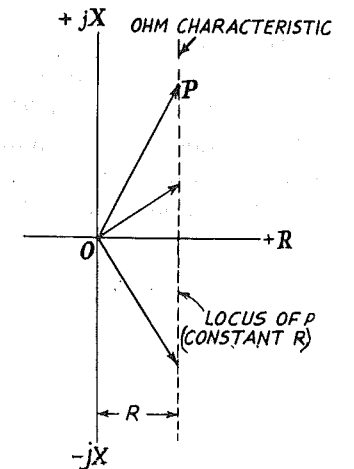

Fig. 29.2. Representation of Z on R-X diagram.



Locus of point P for constant X .
Fig. 29.3 Characteristic of reactance element on R-X diagram.



Locus of constant R .
Fig. 29.4. Characteristic of ohm relay on R-X diagram.

29.3. THEORY OF IMPEDANCE MEASUREMENT

The term impedance applied to resistance plus reactance. We know that the ratio of voltage across a branch to current in the branch gives impedance of the branch, i.e.

$$\frac{V}{I} = Z = R + jX$$

The impedance relay operates for certain conditions of the ratio V to I which may expressed as impedance.

In any impedance relay, there are two actuating quantities namely V and I . The current gives operating torque. The voltage gives restraining torque.

The characteristic in terms of V and I is shown in Fig. 29.5.

The impedance relay can be made to sense the ratio between voltage and current at a point on the line. In such a case we can say the relay is sensing the impedance. The impedance between the location of CT, VT and the fault is proportional to the distance between the above location and the fault. Hence impedance relay is called distance relay. Such a relay operates if the impedance is below that of the relay setting, hence if the fault is within a certain length of the transmission line.

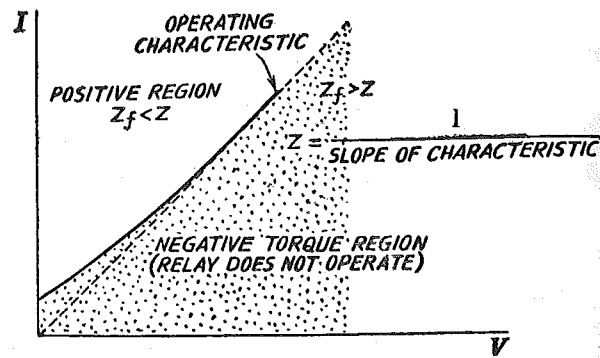

Fig. 29.5. Operating characteristic of an impedance relay.

Distance relay is a versatile family of relays that includes

1. **Impedance relay** ; measures... Z .
2. **Reactance relay** ; measures... X .
3. **Mho type relay** ; measures a component of admittance Y .

A distance relay is one whose operation is based on measurement of impedance, reactance or admittance of line between the location of relay and the fault point.

29.3.1. R-X Diagrams of Plain Impedance Relay

In Fig 29.5, the operating characteristic of an impedance relay on V-I plane. It is in the form of a straight line. By adjustment, the slope of the operating characteristic can be changed.

The more convenient way of describing the operating characteristic of a distance relay is by means of 'Impedance Diagram' or R-X diagram. Since the relay operates for certain value, less than the set value of, the Z operating characteristic is a circle of radius Z .

Any value of Z_f less than the radius of the circle produces positive torque. Any value of Z_f more than the radius, of circle produces a negative torque and relay does not operate. This is a rule regardless of phase angle between V and I .

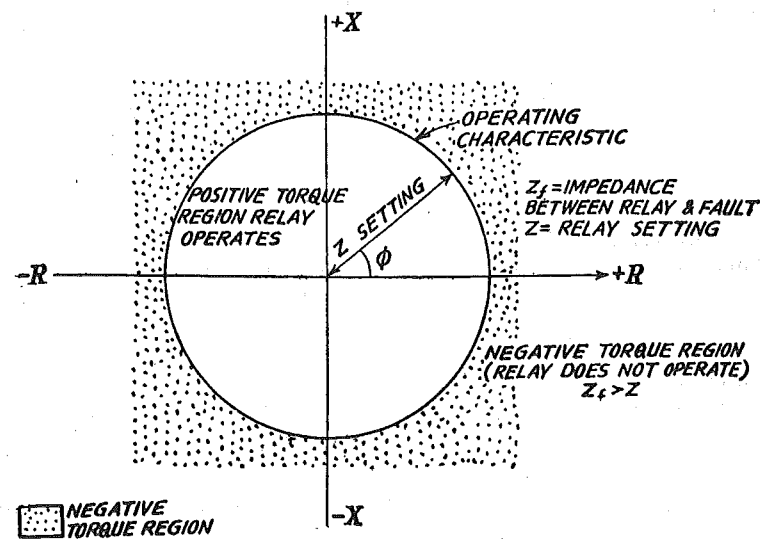

Fig. 29.6 R-X diagram of impedance relay for characteristic shown in Fig. 29.5.

29.3.2. Plain Impedance Characteristics.

The plain impedance characteristic shown in Fig. 29.7(b) is the simplest in use and consists of a circle with centre at the origin.

Operation occurs in the shaded area inside the circle. The significance of this is that the relay operates below certain impedance level, which is independent of the phase angle between voltage and current. A straight line on VI plane (Fig. 29.5) having a constant slope gets converted into a circle of radius V/I on R-X plane.

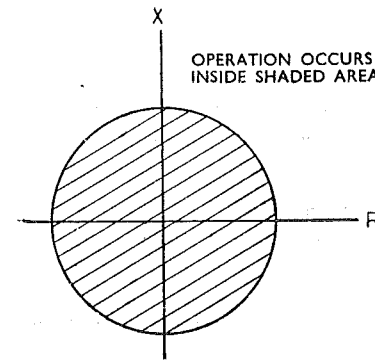
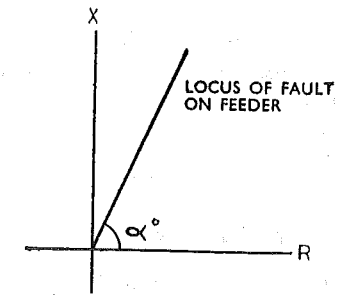

Fig. 29.7 (b). Plain Impedance Characteristics of relay.



α -Phase angle of feeder Impedance. Fig. 29.7 (a). Impedance Diagram of System Fault.

The resistance and reactance between the relay location and fault can also be plotted on R-X diagram as shown in Fig 29.7(a). The angle α will depend upon ratio R/X of line per unit length. For a given fault condition, the measured impedance can be marked on this line [Fig. 29.7(a)]. The line can also be superimposed on the relay characteristic (Fig. 29.8). If the measured impedance of line is within the circle, the relay operates, the circle gives the relay characteristics. The distance along transmission line can be represented by a line on R-X diagram. By superimposing the line characteristic, on the relay characteristic, the operation of the relay can be predicted. (Referring to Fig. 29.8)

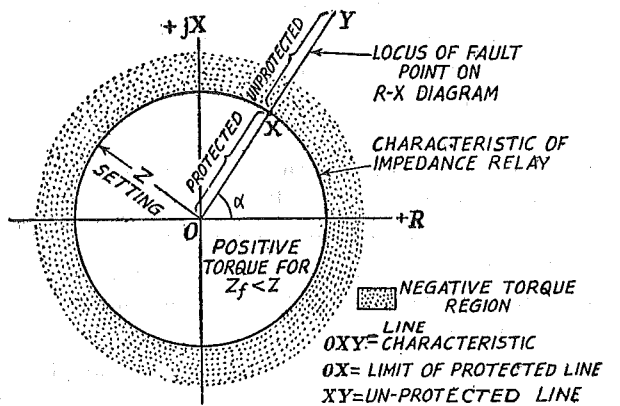

Fig. 29.8. Superimposition of line characteristic OXY on relay characteristics.

OX represents the feeder on RX diagram. If fault occurs within distance OX , the relay operates. For fault beyond X region XY , relay does not operate.*

29.3.3. Disadvantages of Plain Impedance Relay.

Plain impedance relay has the following disadvantages.

- It is non-directional. It responds to the faults on both sides of CT,VT location. Hence it cannot discriminate between internal and external faults.
- It is affected by arc resistance of line fault and results in under-reach.
- It is sensitive to power swings as a large area is covered by the circle on each side on R-X plane.

* Ref. Sec. 42.13 and 42.14 for Examples on setting distance relays with the help of R-X diagram.

29.3.4. Time Characteristic of High Speed Impedance Relay

Fig. 29.9 shows a typical operating time vs. impedance characteristic of a high speed impedance relay for one value current. For other currents similar characteristics are obtained. It is observed that for impedance values above 100% pickup impedance, the relay does not operate. The curve I represents actual characteristics. Curve II is simplified representation of the same (right angle instead of curve).

The relay unit used for distance protection are double actuating quantity instantaneous relays. The electromagnetic relays of balanced beam type or induction cup type are preferred.

Static impedance relays are preferred in modern installations.

29.4. METHODS OF ANALYSIS

Characteristics of various types of distance relays of R - X plane are in form of circles or sectors of circles.

There are mainly three categories of these characteristics on R - X plain

- Circle with centre at origin.
- Circle with circumstances passing through origin.
- Semi-circle above a directional line passing through origin.
- Circle enclosing the origin.
- Circle cut-off from top by a line parallel to X -axis.

These varieties of characteristics are obtaining by changing the operating coil/restraining coil design, providing the additional polarised coils supplied by voltage or current, providing two or more elements within a single relay case.

The type of relay can be identified on the basis of the form of characteristic on R - X plane.

The characteristic of transmission line is, as a rule, a straight line on R - X plane. The length of the line is proportional to the length of transmission line.

The length of transmission line covered by positive torque region of relay characteristics indicates the reach of distances relay, *i.e.* the length of line protected by the relay. (Ref Sec. 42.13).

29.5. DIRECTIONAL IMPEDANCE RELAY

Directional features senses the direction in which the fault power flows with respect to the location of CT and VT. Directional impedance relay operates for following conditions :

- Impedance between fault point and relay location is less than the relay setting Z .
- The fault power flows in a particular direction from relay location. The direction power flow is sensed by measuring phase angle between voltage and current.

Directional Characteristics

The characteristic presented on R - X diagram is a straight line passing through the origin as shown in Fig. 29.10. Operation takes place on one side of the line as indicated by shading.

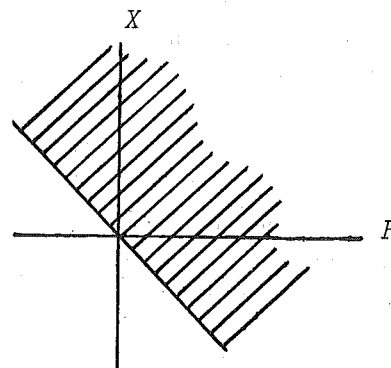

Fig. 29.10. Purely directional characteristics (operation in shaded area).

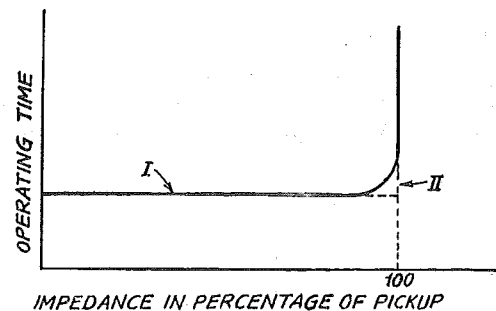

Fig. 29.9. Time characteristics of high speed impedance relay.

Suppose the location of fault. Point (with corresponding R and X) is plotted on R - X diagram.

In case of Directional Relay, the positive torque is provided when the fault point lie on right hand side of the inclined line (Hatched area in Fig. 29.10). This line when superimposed on the characteristic of plain impedance relay, we get final characteristic of Directional Impedance Relay (Fig. 29.11)

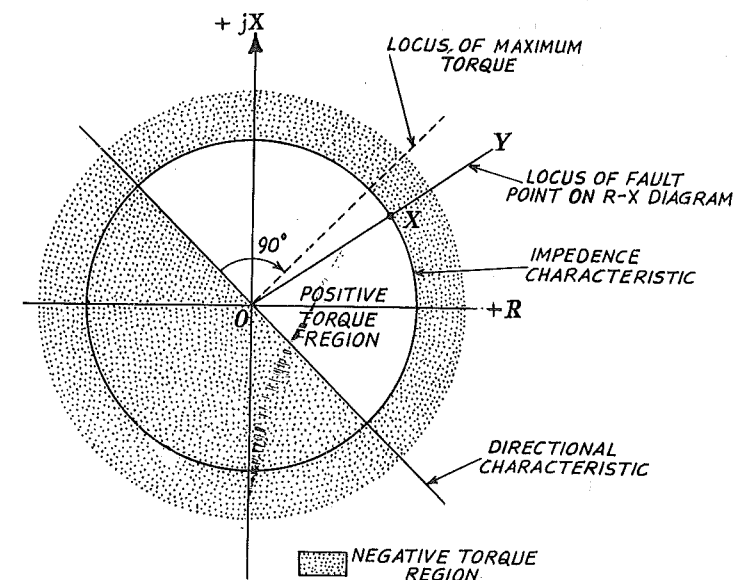

Fig. 29.11. R - X Diagram of Directional Impedance Relay.

With Directional Characteristic added to the plain impedance characteristic, the results in a characteristic with a sector of a circle (Fig. 29.11). Consider a locus of fault point on transmission line (locus OY). Angle $ROY = \alpha$ depends upon the phase angle between V and I with given setting of directional element, the operating torque is positive within the semi-circle with radius Z and on right hand side of the inclined line of directional characteristic DD' .

For faults on one side of the relay location, angle α lies between angle DOD' . Hence relay operates for two conditions :

- Locus OXY should have angle α with angle DOD' given by Directional Feature.
- Impedance measured by relay should be less than the Setting Z .

29.6. TORQUE EQUATION OF DIRECTIONAL IMPEDANCE RELAY

The directional relay responds to the phase angle between V and I at relay location.

Suppose torque of directional unit is given by,

$$T = K_1 VI \cos(\phi - \theta) \quad \dots(1)$$

where T = Torque

K_1 = Constant

V = Voltage supplied to relay coil

I = Current supplied to relay coil

ϕ = Phase angle between V and I

θ = Angle of maximum torque

when the relay is on verge of operation.

$$T = 0$$

Hence $\cos(\phi - \theta) = 0$

i.e. $(\phi - \theta) = \pm 90^\circ \quad \dots(2)$

Hence for positive torque, ϕ should be within $\theta \pm 90^\circ$.

This directional characteristic when presented on R - X diagram is a straight line (DOD) for which ϕ is within $\theta \pm 90^\circ$.

However, impedance characteristic puts another conditions, i.e. $V/I < Z$ represented by a circle on R - X diagram (Ref. Fig. 29.11). Hence the net characteristic of directional impedance relay is a semi-circle above a straight line passing through zero. (Fig. 29.11). The radius of circle corresponds to measured impedance.

29.7. MODIFIED (SHIFTED) CHARACTERISTIC

The impedance unit may be given a current bias, i.e. the voltage coils is supplied by additional voltage proportional to line current (say DI), Basic Torque equation gets modified to

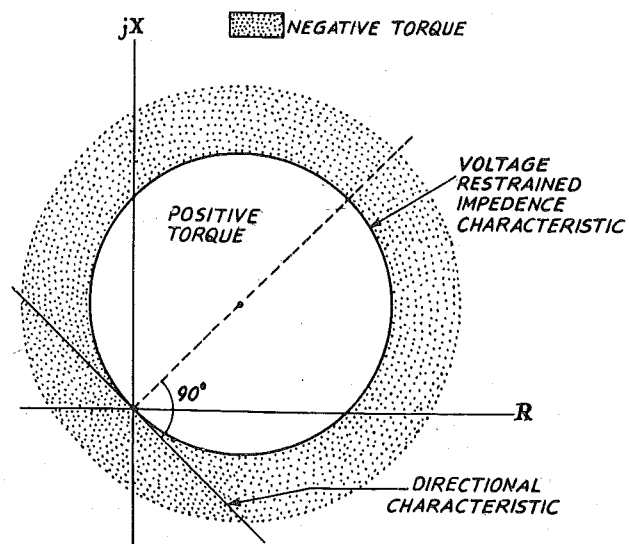

Fig. 29.12. Directional offset impedance characteristic on R - X plane.

$T = K_1 I^2 - K_2 (V + DI)^2 (V + DI)$ is the voltage supplied to voltage coil of impedance relay.

The characteristic when plotted on R - X diagram is a circle with radius V/I and with centre shifted from origin.

The circle may be completely 'offset' from the origin so much so that origin is left out of the circle.

Directional feature combined with offset impedance characteristic is shown in Ref. Table 29.1.

29.8. REACTANCE TYPE DISTANCE RELAY

The reactance relay has a characteristic such that all the impedance radius vectors whose outer ends lie on a straight line having constant X component. X is the reactance of protected line between the relay location and the fault point.

The reactance type distance relay has reactance measuring unit. The reactance measuring unit has an overcurrent element developing positive torque and a directional element ($VI \cos \phi$) which either gives a positive or negative torque.

Hence reactance relay is an over-current relay with directional restraint.

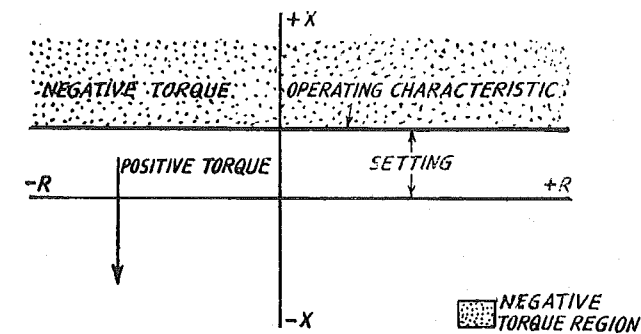

Fig. 29.13. Ideal characteristic of plain reactance type distance relays (simplified).

The directional element is arranged to develop maximum negative torque when current lags behind voltage by 90° , (i.e. $\phi = -90^\circ$).

The complete characteristic of voltage restrained reactance relay is illustrated in Fig. 29.14.

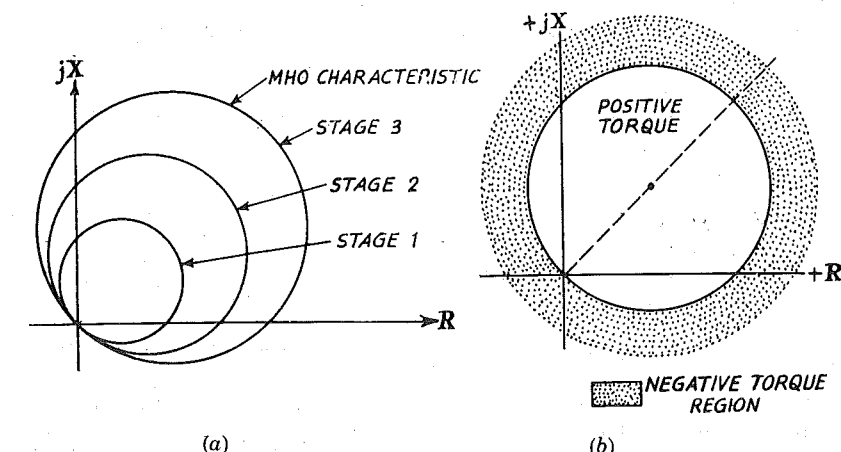

Fig. 29.14. Voltage Restrained Directional Characteristic (Ohm Characteristic).

29.9. MHO TYPE DISTANCE RELAY

Mho relay is also known as *Admittance Relay* and measures a component of admittance $Y < \theta$. It is also called as angle impedance relay.

The characteristic of mho relay on admittance diagram is a straight line.

The mho characteristic on R - X diagram is a circle passing through origin. This characteristic is obtained by polarizing the impedance relay and directional relay (refer : reactance type distance relay). From Fig. 29.14 the following points can be noted :

1. Characteristic is directional and will operate for faults in one direction only.
2. Relative reach of the relay goes on changing for various ratios of R/x .

Summary

The distance protection responds to the ratio V/I . The impedance relay is set for a value Z such that when the value V/I measured by the relay is less than the set value Z , the relay operates. Characteristics of Distance Relays are plotted on a R - X plane. Distance Relays are used for protection of transmission lines, distribution lines etc. These relays are generally high speed relays.

Details about distance protection schemes are given in Chapter 30.

29.10. APPLICATION OF DISTANCE PROTECTION

Distance protection schemes are used universally for protection of high voltage AC transmission lines and distribution lines. They have replaced the over-current protection of transmission line (Refer Part 30.A). The success of distance protection is due to the following :

- faster protection — simpler co-ordination
- less effect of amount of generation and fault levels, fault current magnitude.
- permits high line loading
- simpler application ; permanent setting without need for readjustments
- static distance relays have superior and versatile characteristics (Refer Ch. 42) Sec. 42.1 enlists several addition merits of static distance schemes.

Distance protection schemes are generally used for providing the Primary Protection (Main Protection) and Back-up protection for AC transmission and distribution lines against

- 3 phase faults — phase to phase faults
- phase to earth faults

In some schemes for short lines, the phase to earth faults protection sensing may be by distance relay and measurement by over-current relays because distance protection for shorter lines are susceptible to errors due to arc fault resistance. In general, the choice of type of distance protection depends on length of line, configuration of lines, whether single infeed/double infeed, tripping time required and co-ordination requirements. Refer Table 30.2 regarding alternative distance schemes. **Today's trend is toward the use of static distance protection for all types of line faults, main and back-up for short, medium and long lines.** These have been dealt in Chapter 42. The following paragraphs give an overall review.

Distance relays respond to the ratio of V/I . They measure impedance V/I or a component of impedance from the location of CT, VT. The measured V/I is proportional to the distance between the location of CT/VT and location of fault. Hence the relays are called distance relays.

The operating limits of an impedance relays are usually specified in terms of impedance components resistance and reactance. *It is convenient to describe the operation limits on R-X diagram on rectangular co-ordinates with resistance R on abscissa and reactance jX on ordinate.* The operating characteristics on R-X diagram in the form of simple geometrical figures such as circles or sectors of a circle or rectangles. Electromagnetic relays can achieve only circular characteristics. **Static Distance Relays can achieve rectangular, quadrangular, lense, type, double-mho and a variety of characteristics on R-X diagram** (Sec. 42.5, 42.17).

The choice of R-X characteristic is made such that the relay operates for line faults in the protected portion of line but remains stable during power swings.

29.10.1. R-X Diagram

The geometrical figure on R-X diagram (a circle, quadrangle or a sector of circle) may be in the first or second quadrant of rectangular co-ordinates. ... (Table 29.1)

Relay Characteristics

The operating region is within the characteristic figure *i.e.* when the measured impedance component is less than the set value (boundary of characteristic figure) the relay operates (Figure 29.7 b). Refer Fig. 29.15.

29.10.2. Line Characteristics

Refer Fig. 29.7 (a) representing line characteristics. The locus of line impedance before occurrence of a fault measured by the relay and plotted on R-X diagram is a straight line passing through

Further References :

- Ch. 30. Distance Protection Schemes.
- Ch. 42. Static Distance Relays and Distance Protection of EHV lines.
- Sec. 42.14. Setting of Distance Relays.

the origin. The angle α of this line characteristic depends on natural ratio of R/X of line per unit length. ($\sin \alpha = X/Z$). Each point on the line represents certain distance from origin in terms of Z .

The setting of the relay decides the radius of the characteristic circle or shape of boundary of the characteristic.

For pre-determining the operation of relay in response to fault on transmission line, the line characteristic. Fig. 29.7 (a) is superimposed on relay characteristic Fig. 29.7(b) as in Fig. 29.8. Refer Fig. 29.17 also.

29.10.3. Condition for Relay Operation (Refer Fig. 29.17)

The fault point F shifts from line end towards origin O depending the location of the fault with respect to location of CT/VT (substation). For a fault away from the sub-station, the point is farther from origin. If it is outside the boundary of the characteristic figure, (Circle or Quadrangle). The relay does not operate. During a fault on line, (assuming negligible fault impedance) the V/I measured between origin and the fault reduces and the point moves towards the origin. If the point moving along the line characteristic comes within the characteristic of the relay (Fig. 29.8) the relay operation.

29.10.4. Operating Time

The time characteristic of high speed distance relays is a straight line (Fig 29.9). The relay operates within set time. When measured Z falls within its pick-up value. If measured Z is beyond its pick-up value the relay will not operate.

29.10.5. Stages of Relay Time Characteristics

The long transmission lines are with intermediate sub-stations. In each sub-station the distance relays are provided for line protection. The settings of these relays are set with respect of impedance (radius of characteristic circle) and operating time (position of horizontal step Fig. 29.9).

The distance relay in each sub-station has generally 3 step characteristic with respective settings of Z and t for each step. The three-step characteristics of distance relay of each sub-station is achieved by providing three sets of relays in each sub-station for protection of each line. Sec. 30.12 and Fig. 30.12 illustrate a three-step characteristic of distance protection of transmission line. Refer. 29.15 also.

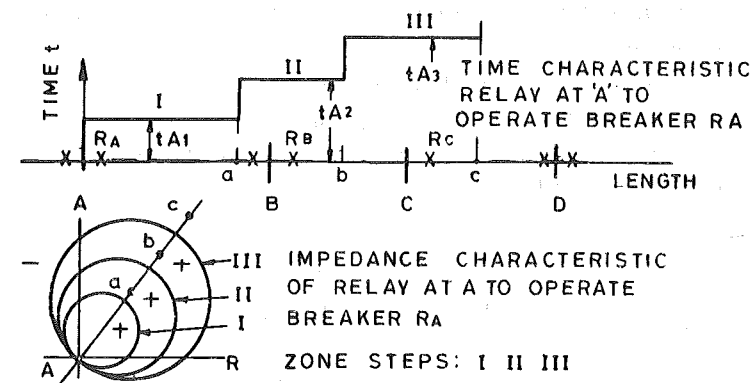

Fig. 29.15. Three-step time-characteristics of Distance Relay at Station A.

3 Step-Characteristics

Ref. Fig. 29.15. This figure explains a time-distance characteristic of a 3-step distance scheme in sub-station A for one direction. There are three sets of relays for protection of each line. Each relay provides characteristic for one zone. The combined effect the distance scheme in substation A provides.

- Primary protection for first zone AB with minimum time setting. Normally 85% of first zone is covered to take care of errors such as fault resistance.
- Remote Back-up (Refer Sec. 25.5.3) for the second zone BC with time setting....and Remove Back-up for the 3rd Zonal CD with time setting...

First Zone. The first zone setting is 85 to 90% of line length and with highest speed of protection so that these relays operate at the earliest and will never operate for the fault in 2nd and 3rd zones. Also the margin of 15 to 10% takes care of fault resistance seen by the relay measurement as additional line impedance.

Underreach. Suppose line impedance is Z_L and arc resistance relay measures $(Z_L + R_f)$ instead of measuring only Z_L . Thereby the relay will see the fault as beyond its characteristic circle and will not operate even though it should have operated. This is called *Underreach* Defn. Sec. 25.8.(34).

Second Zone. The second zone relay at A provides protection for remaining 15 to 10% of line section AB . The relay is set to reach beyond the length AB and twenty to fifty per cent of the next line section BC . For achieving time co-ordination, the second zone relay at sub-station 1 is set with time t_2 with a time delay of 0.2 to 0.5 seconds between the first zone t_1 and second zone t_2 . The primary protection for section BC is provided by first zone relay at sub-station B.

Third Zone. The third zone relay at A provides back-up protection for section AB , BC and CD . The primary protection for line section CD is provided by first zone relay at sub-station C.

Third zone protection at sub-station A is delayed by 0.4 to 1 second from first zone and 0.2 to 0.5 seconds from second zone.

29.10.6. Co-ordinated Characteristics of Distance Relays in three stations.

Fig. 29.16 illustrates the time distance characteristic settings of Distance Relays at Station A, B, C for one direction. Similar relays are provided for other direction.

1. Relays at Sub-station A

3-step distance characteristic of relay at sub-station A having following features :

- **First Zone.** Primary protection to 85 to 90% on line AB (First Zone) with time t_{A1} to operate breaker RA .
- Second zone covering remaining 15 to 10% of section AB and about 20 to 50% of section BC with time t_{A2} .
- Third zone covering remaining 80 to 50% of section BC and further 20% of section CD .

2. Relays at Sub-station B

This has three-step characteristic just like that of sub-station A.

1. First zone protects 85 to 100% of section BC as primary protection with time t_{B1} and, second zone covering remaining 15 to 10% of BC with higher time. Third zone covering remaining protection of line BC and further 20% of line CB .

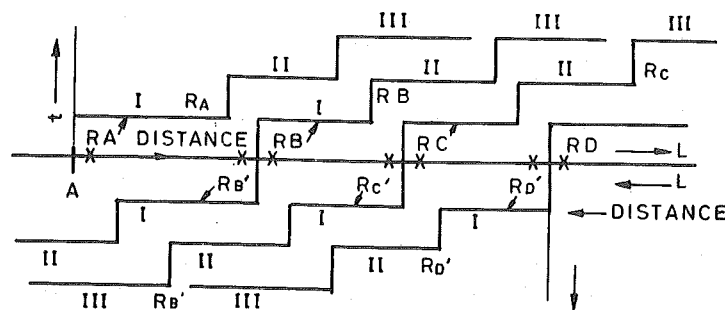

Fig. 29.16. Co-ordination of 3-step time characteristics at Station A, B, C for forward and opposite directions.

2. Relay at station B provides primary protection to section BC and remote back-up to DC , DE .

3. Relay at Sub-station C

This provides primary protection to 85 to 90% of section CD as first zone protection with minimum time t_{C1} . This is primary protection at sub-station C to operate breaker R_C .

Three steps in R-X Diagram

The impedance characteristics of zone 1, 2, 3 are similar geometrical figures with different impedance settings (Fig. 29.14). In case of static distance relays with quadrangular characteristics, the characteristics of 3 zones are in the form of different straight lines forming the quadrangle.

29.10.7. Significance of R-X Diagram and Method of Analysis

A distance relay should operate below set fault impedance within set-time. It should not fail to operate for faults beyond protected zone. It should operate for faults within protected zone. It should not operate due to power swings. For the purpose of analysis and choice of settings of first zone, second zone and third zone Distance Relays in each sub-station and their co-ordination; the R-X Diagram is very useful. The following characteristics are plotted on the same R-X diagram.

- Relay characteristic (circle or sectors of circles or some geometrical shapes).
- Line characteristic (Straight line passing through origin)
- Load impedance region
- Power swings.

Relay characteristic should cover the line characteristic.

Relay characteristic should be away from load region. Normal power swing should touch relay characteristic. Ref. Fig. 29.17.

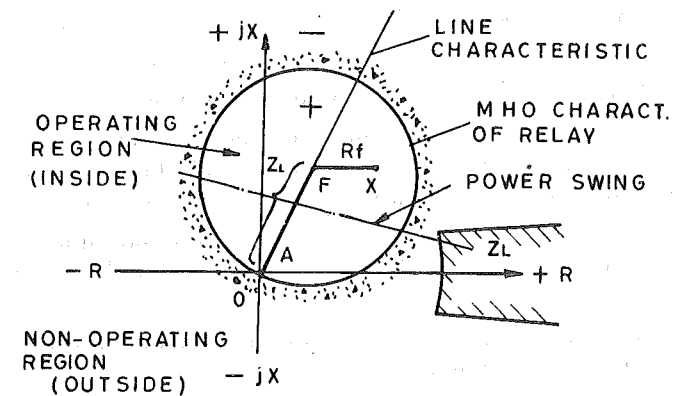

Fig. 29.17. Summary of characteristic of a distance relay.

29.10.8. Load Impedance

The load on transmission line represented by certain load impedance having certain R and X values. This is covered by region Z_L shown in Fig. 29.17.

Load impedance is much higher than fault impedance and line impedance. Therefore, the distance relay does not operate due to change in load impedance under normal load conditions. During faults on the line the measured line impedance falls. Operating point suddenly comes from region Z_L on line AB .

29.10.9. Line Impedance

This is represented by a straight line passing through the origin. During no-load the point on the line represents the impedance seen by the relay from origin. During the fault, the relay will measure the line impedance upto fault point.

Fault Resistance. The faults on overhead line will be arc faults having pure resistance R_f . This is represented by a horizontal line on R-X diagram.

Total impedance measured by the relay is equal to line impedance upto fault point (Z_L) plus arc resistance (R_f) i.e. $Z_L + R_f$.

The relay characteristic should be broad in the middle (Fig. 29.17) and Fig. 42.31) so that X is within relay characteristic.

29.10.10. Power Swings

During switching of lines, large loads or generating units, surges of real power and reactive power flow through transmission lines causing oscillations in the voltage vectors and current vectors (Sec. 42.9).

The power swing is represented by a curve originating in load region and travelling towards relay characteristic.

During power swings the measurement of V/I by distance relays at sending-end and receiving-end sub-stations do not represent true V/I characteristic of the line. The measurement is falsified by power swings and the distance relay may operate wrongly if the measured V/I falls within the operating characteristic of the relay (Sec 42.9.2). The power swing point travels from load region L towards relay characteristic as shown in Fig. 42.18.

The shape of characteristic is such that the minor low magnitude power swings approaching from load region do not enter the enclosed area of the relay characteristic. For this purpose the characteristic is narrow near the bottom half region. The area of characteristic is restricted at the bottom and enlarged at the top.

The static relays are provided with features to block the relay against permissible power swing but operate for faults.

29.10.11. Choice of Characteristic Mho/Reactance Mho/Static

The various types of characteristics on R-X diagram have been re-viewed in Table 29.1.

Plain impedance characteristic has several limitation mentioned in the Table 29.1 (a).

Solved Example 42.1 (a) in section 42.14 illustrates how the relay fails to detect a fault within 80% of protected line because of fault resistance R_f . In past plain impedance relay was used extensively for long lines and short lines. However, now it is no more preferred.

Mho-characteristic (Table 29.1 C) is used for protection of long lines. The characteristic is a circle passing through the origin on R-X diagram and with axis almost coinciding with the line characteristic.

The measurement error due to arc fault resistance remains within the characteristic circle as shown in Figs. 30.13, 30.14 and Example 42.2.

Hence such a characteristic is preferred for short lines. Oval characteristic (Fig. 42.9) for Quadrangular characteristic (Fig. 42.11 and Fig. 42.28). These are achieved by static relays and are such that arc fault resistance is within relay characteristic (board at middle) and minor power swings do not touch relay characteristic (narrow at the bottom).

With modern static relays, a very wide choice of relay characteristic and settings are available. The choice is made on the basis of application requirements.

QUESTIONS

1. Describe the principle of impedance type distance relay and explain its characteristic on $V-I$ and $R-X$ planes.
2. Derive expressions for torque developed by a double activating quantity distance relay. Show that the relay operates when fault is within the protected distance of line.

3. Explain the Directional Impedance relay by means of its characteristic on $R-X$ plane.
4. Write short notes on :
 - Reactance Relay — Mho Relay — Directional Impedance Relay
5. Explain the principle of following distance characteristics with the help of R-X diagram.
 - Plain impedance characteristics. — Directional impedance characteristics
 - Plain Reactance characteristics — Mho characteristics
 - Offset Mho characteristic
6. Define the following terms and explain their significance in distance protection.
 - Reach of a distance relay — Under-reach
7. Explain how the arc resistance introduces an error in distance measurement.

Refer Sec. 42.13 and Sec 42.14 for examples on setting of Distance Relays.

Refer Ch. 42 for static distance relays.

Refer Ch. 30 for Sec. 30.8 to 30.16 for applications of distance relays.

Protection of Transmission Lines

Introduction — Choice of Protection — **Over Current Protection** — Time graded non-directional Protection — Setting of Inverse time over current relays — Current graded systems — **Distance Relaying** — Impedance, Reactance, Mho relays — Overreach, arc resistance — Carrier aided distance schemes — **Pilot Wire Protection** — Principle of Merz Price Protection — Voltage balance type — Discriminating factor — Transley system — Limitations of Pilot wire systems — **Carrier Current Protection** — Equipment — **Radio Links** — Summary

30.1. INTRODUCTION*

There are several methods of protection of transmission lines. The first group of *non-unit* type of protection which includes

1. Time Graded overcurrent protection
2. Current Graded overcurrent protection
3. Distance protection. Such non-unit type protections do not have pilots. The discrimination is obtained by coordinating the relays settings. Fuses are used in distribution systems, where relays and circuit breakers are not necessary and fuses are preferable due to their low cost, current limiting features etc.

The other group of protection of line is *unit-type* of protection such as pilot wire differential protection, carrier current protection based on phase comparison method ; etc.

Separate protection are systems are necessary for earth faults because earth faults are more frequent on overhead transmission lines than phase faults, and earth fault current is different from phase fault current in magnitude.

Time and current Graded protection is used where a time-lag can be permitted and instantaneous operation is not necessary, *i.e.*, where time-lag in fault clearance does not cause instability or damage to cables, lines, etc. In addition they are used as a back-up protection to the main unit protection.

Distance relaying is employed where time and graded current relaying is too slow or selectivity is not obtained from them. In other words distance relaying is applied for faster protection. In distance relays there are three main types of measuring units, namely : Impedance, Reactance and Mho type distance relays. Each type has certain advantages and disadvantages. For very short lines reactance type is preferred because it is practically unaffected by arc resistance. For short line resistance is large as compared to the line impedance. For medium length lines, impedance relay is suitable but likely to operate wrongly on severe reactive power surges. Mho type relays are used for phase faults of longer lines.

Distance schemes comprise starting elements, measuring elements, timer elements. There are two broad categories called switched and non-switched schemes. Carrier aided distance schemes include carrier acceleration, carrier blocking and intertripping schemes.

* Ref. Ch. 42 "State Distance Protection of EHV Lines".

Table 30.1. Protection of Transmission Lines.

Type of Protection	Remarks
Overcurrent Protection — Time graded or current graded — Directional or non-directional	Applied as main protection for distribution lines and back-up for main lines, where main protection is of distance or other faster type. Inverse define minimum time relays preferred for time graded systems. Instantaneous relays for current graded systems.
Earth-fault Protection	Separate earth-fault protection is necessary in addition to phase fault protection. Type of earthing and magnitude of earth fault current should be considered. Faster than overcurrent protection. Several combinations of schemes available depending upon length of line.
Pilot wire differential protection.	For important lines of relatively shorter length (a few tens of km).
Carrier Current Protection	Where length of transmission line is long and simultaneous opening of circuit-breakers at both ends is necessary.

*Single shot auto-reclosure schemes are used for high voltage overhead lines.

Unit protection provides fast selective clearing. Pilot wire protection based on differential circulating current principle (Merz-Price) and other types are used for short lines where cost of pilot wires is not prohibitive. Carrier current protection is used for long lines, interconnected lines. It provides a fast relaying. Radio signals of frequency bands 1000—3000 MHz are used U.S.A. for protection of feeders.

Auto-reclosure schemes are incorporated in the protection of distribution lines and transmission lines. Auto-reclosure (Ref. Ch. 44) of distribution lines is mainly for improving service continuity. Whereas Auto-reclosure of transmission lines is mainly for improving system stability (Ref. Sec. 2.13 and 2.14)

The principles of protective relays and protection schemes discussed in Ch. 25 to 29 will be further studied with reference to protection of transmission lines.

PART 30 A. OVERCURRENT PROTECTION OF TRANSMISSION LINES

30.2. NON-DIRECTIONAL TIME GRADED SYSTEM OF FEEDER (OR LINE) PROTECTION (Ref. Ch. 27)

In this system the time setting of over-current relays at different locations is graded. Fig. 30.1 illustrated the principle of time graded overcurrent protection of a radial feeder (line).

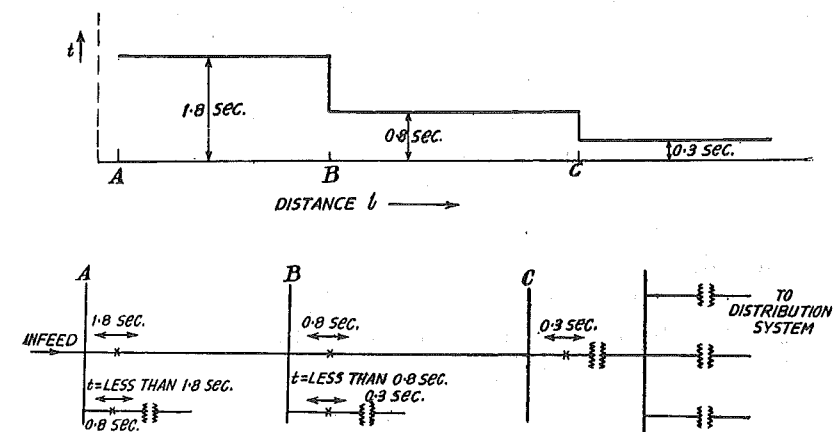

Fig. 30.1. Graded time lag overcurrent protection of a radial feeder (Non-directional).

Fig. 30.1 shows two sections of radial feeder connected between stations A, B and B, C . The relaying is provided at each station A, B, C, D . The arrow marks pointing towards both directions indicate that the relays operate for faults on either sides. The time lag is indicated on the arrow head.

For a fault beyond station C the circuit breaker at C operates first, *i.e.*, with relay time of 0.3 second. Meanwhile the other relays at station B and A start operating but after about 0.3 second the fault is cleared and the relays at A and B get reset. Therefore for faults beyond C , only the CB at C operates. For faults between B and C only CB at B operates and likewise. Thus unnecessary tripping is avoided. Secondly by some failure if the relay at B fails to operate, the relay at A provides, back-up protection.

This system is suitable for radial feeder in which power flow is only in one direction.

Inverse definite minimum time delay relays are extensively used for obtaining combination of current and time gradings.

Time interval of 0.5 sec. is usually found suitable, this covers errors in CT , relay and CB operating time. Hence operating times of relays in consecutive stations can be 0.3, 0.8, 1.3, 1.8, seconds.

At sub-stations B and A transformers are shown connected to the station bus. The time setting of the relays in this connection should be less than setting of the relays on the main feeder.

We graded inverse time protection, the characteristic of relays should be taken into account while setting the relays. With inverse relays, the time setting and plug setting can be preset. The fault current is calculated. The time interval of 0.5 second is provided between consecutive relays and operating times are calculated. The plug settings and time settings are so arranged that for a fault on last section (beyond C), the desired operating times are obtained.

Time graded overcurrent protection for phase faults is supplemented by time graded earth fault protection. The earth fault relay is residually connected. In general, two relays are employed for phase faults and one for earth fault. Since both phase fault and earth fault relays are set for short circuits, they do not detect over-loads of small magnitude. Overload protection may be provided in addition, with long time setting (minutes) and low current setting.

Setting of Inverse Overcurrent Relays for Co-ordination

Step I. Choose pick-up of the relays so that they will operate as follows : (Ref. Sec. 26.6)

1. Operate for short circuits in its own line section.
2. Provide back-up protection to the next line section.

For a phase relay phase to phase fault is assumed. For an earth fault relay, a single line to ground fault is assumed.

The operating time is graded by considering the following aspects :

$$T_A = T_B + CB_2 + O_A + F$$

T_A = Operating time of relay at station A

T_B = Operating time of relay at station B

CB_2 = Operating time at circuit breaker at station B

O_A = Overtravel time at station A

F = Factor of safety.

Considering, arbitrarily

$$T_B = 0.8 \text{ second}$$

$$CB_2 = 0.16 \text{ second (assuming 8 cycle Breaker)}$$

O_A = Overtravel time = 0.1 sec

F = Factor of safety = 0.2 sec.

$$T_A = 0.8 + 0.16 + 0.1 + 0.2 = 1.26 \text{ sec.}$$

Hence the time of relay at A should be atleast 1.3 seconds.

Overtravel is the travel of a relay moving elements after the actuating force is removed. This overtravel occurs because of inertia of moving parts. Overtravel is important feature of a time-delay relay where selectivity is obtained by time lag. Overtravel of 0.1 sec. is generally assumed for inverse time relays.

The next step in co-ordination is adjustment of time lag of inverse time overcurrent relays to obtain selectivity. The equation given above is used for determining the time settings of relays in the adjoining sections.

The procedure of selecting time setting and plug settings is as follows. The time multiplier setting of the relay at remote and from the source is set to a low value, say 0.1. The interval of 0.4 to 0.5 second is added to select operating times of relays at consecutive stations, as described earlier. Suppose T_0 is the required operating time.

$$\text{Then, } T_0 = T_m \times TMS$$

where TMS = Time multiplier setting.

T_m = Time from relay characteristic for time multiplier setting of 1
and for plug setting equivalent to maximum fault current.

For example, suppose fault current = 3000 amperes, relay is set to operate for primary current of 300 amperes, then plug setting multiplier is equal to $3000/300 = 10$. See from the characteristic of the relay, the operating time of relay for plug setting multiplier of 10. This corresponds to time setting of 1. This time is T_m . Suppose T_m is 2 seconds. From the relay co-ordination point of view, the desired operating time T_0 is say 1 second. Then time multiplier is set to

$$TMS = \frac{T_0}{T_m}$$

which in this case is given by,

$$TMS = \frac{1}{2} = 0.5.$$

(Definitions and explanations of TMS and PS are given in Sec. 26.11, Ref. Sec. 26.6 for plug setting.)

Disadvantages of Graded Time lag Overcurrent Relaying

1. Time lag is to be provided, time lag is not desirable on short circuits.
2. The method is not suitable for ring mains or interconnected lines. It is suitable for radial lines with supply at the one end only.
3. It is difficult to co-ordinate and needs changes with new connections.
4. It is not suitable for important, long distance transmission lines where rapid fault clearing necessary to ensure stability of systems.

30.3. DIRECTIONAL TIME AND CURRENT-GRADED SYSTEM

To obtain discrimination, where power can flow to the fault from both the directions, the circuit breakers on both the sides should trip, so as to disconnect the faulty line. Such case occurs in parallel feeders, ring mains, T feeders, interconnected lines. Directional time and current graded systems are suitable in such cases.

Here the directional relays can operate for fault current flowing in a particular direction shown by arrow \rightarrow (Fig 30.2)

In the diagram, the double headed arrow \leftrightarrow indicates non-directional relay. In Fig. 30.2 (a) a fault on feeder I will trip only circuit-breakers at the end of feeder I . The circuit breaker at the ends of neighbouring feeder (II) would not trip as a main protection.

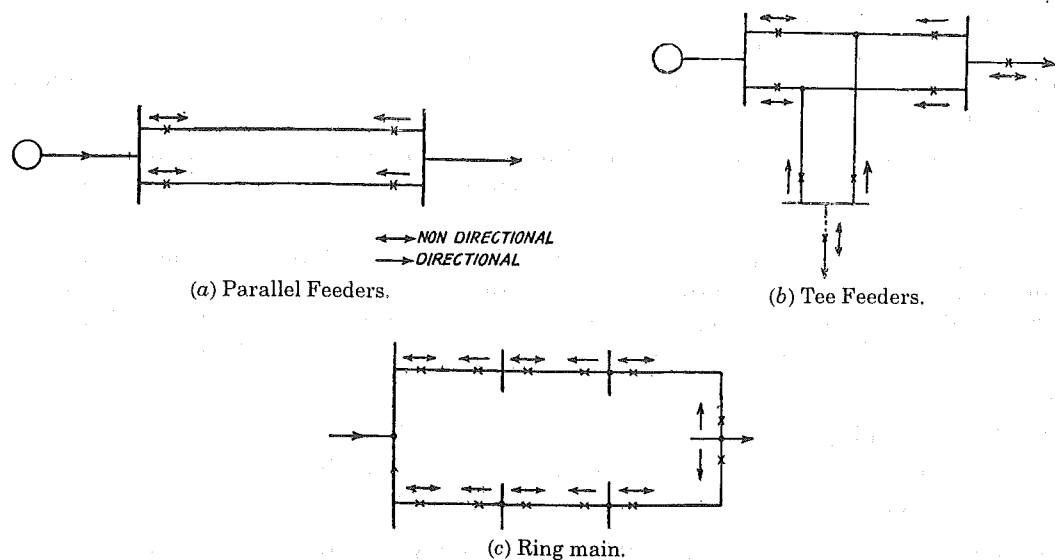
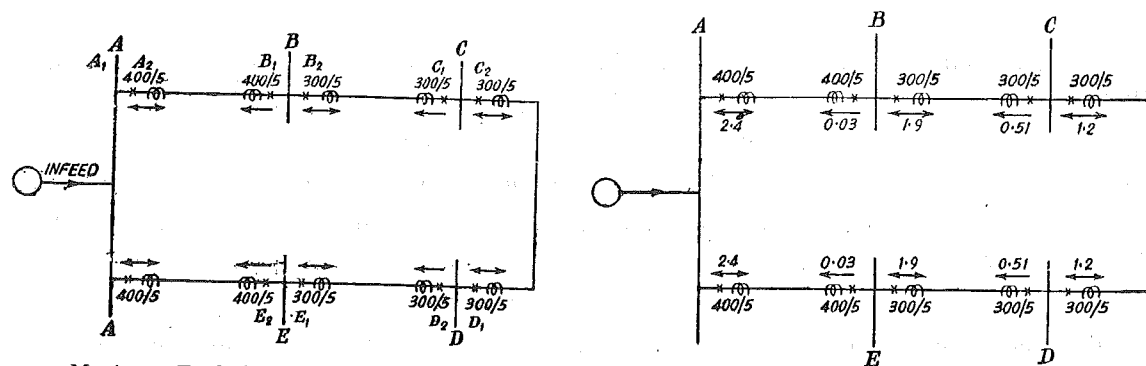

Fig. 30.2. Typical directional protection schemes.

30.4. SETTING OF DIRECTIONAL OVER-CURRENT RELAYS OF A RING MAIN

Fig. 30.3 illustrates the setting of a directional overcurrent relaying for 3 ph. faults. For faults between *B* and *C* the relays *B*₂ and *C*₁ operate first and *BC* is disconnected from the ring main. So, also for the faults on other sections, the faulty section is disconnected from the system.

If, in addition to directional overcurrent feature, time lag is necessary to obtain selectivity, the graded time lag is used. The time lag of directional relays is selected such that it is minimum for relay near the source. Fig. 30.4 illustrates the principle.



Maximum Fault Currents 3 Ph. Fault

Via AB	Via AE
A = 12000 A	A = 12000 A
B = 8000 A	B = 8000 A
C = 5000 A	C = 5000 A
D = 3000 A	D = 5000 A
E = 2000 A	E = 2000 A

Fig. 30.3. Example of directional over-current relay settings Load connections not shown.

Fig. 30.4. Example of time grading of directional earth fault relays.

30.5. CURRENT GRADED SYSTEMS

An alternative to time grading or in addition to time grading current grading system can be applied when the impedance between two sub-stations is sufficient and current grading can be applied. The long time delays occurring in graded time lag system can be partly avoided. Current

graded systems normally employ high speed high set over current relays. They operate at pre-determined setting without a time lag.

Fig. 30.5 illustrates the protection of a radial feeder with instantaneous overcurrent relay.

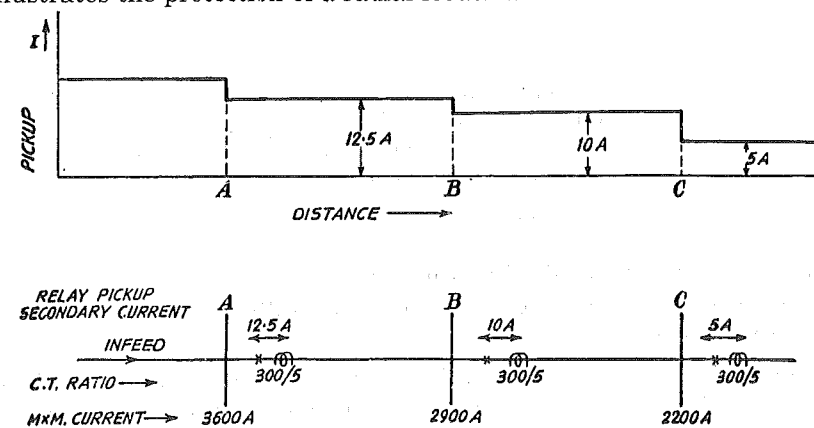

Fig. 30.5. Graded current protection of a feeder (Non-directional).

For a fault beyond *C* relay at *C* is actuated. For fault between *C* and *B* is actuated. For fault between *B* and *A* relay at *A* is actuated. The current setting diminishes progressively from the source to the remote end of the line.

Difficulty. (a) If a fault is very near to station *B* in section *BC*, the relay at *A* may feel that it is in section *AB* because there may be very little difference in the fault currents and the relays do not discriminate between the fault in the next section and the end of first section. The reason being

1. Difference in fault currents is low.
2. Magnitude of fault currents cannot be accurately determined.
3. The accuracy of relay under transient condition is likely to be different.

Therefore, to obtain discrimination only about 80% lines protected by relay at one station. Since only 80% of line is protected this system should be supplemented by time graded inverse definite minimum time relay system.

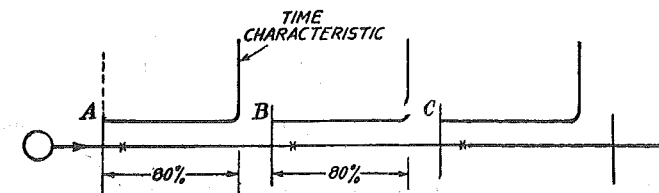

Fig. 30.6. Instantaneous overcurrent protection of line. (It is supplemented by time graded back-up).

(b) The fault currents for different types of fault are different. This brings a certain difficulty in relay setting.

(c) For ring mains, parallel feeders etc. where power can flow to the fault from either directions, a system without directional control is not suitable.

Instantaneous and IDMT Protection

Instantaneous overcurrent relays in conjunction with inverse definite minimum time (IDMT) relays can be used for high speed protection of radial lines. The coils of instantaneous element and IDMT element are connected in series. Fig. 30.7 illustrates the characteristics of the combination. The instantaneous element has a characteristics like Fig. 30.6.

Such protection can be effectively applied only if the following conditions are satisfied :

- The fault level at the sending end of the line is at least thrice that at the receiving end of the line.
- The changes in the generating station do not change the fault current significantly.

The instantaneous element should be set for more than 150% of maximum fault current at the end of the line section which it protects. For example, the instantaneous element at section A should be set for more than 150% at maximum fault current at section B. Such a margin takes care of transient and over-reach.

Over-reach of Instantaneous Over-current Relay

Over-reach is a tendency of a relay to pickup for faults further away from what is expected from a relay neglecting the d.c. component of a fault current. Magnetic attraction type relays are most affected by over-reach because they are sensitive to d.c. component. Certain induction relays are least affected by d.c. component. Percentage over-reach is defined as

$$\text{Percentage over-reach} = \frac{A - B}{B} \times 100$$

where A = relay pick-up current steady state r.m.s. value

B = r.m.s. value of steady state current which when fully offset causes relay pickup.

To take into account the d.c. component, the maximum value of symmetrical value of current for which the relay should not operate, should be multiplied by about 1.25, to obtain relay pick-up setting.

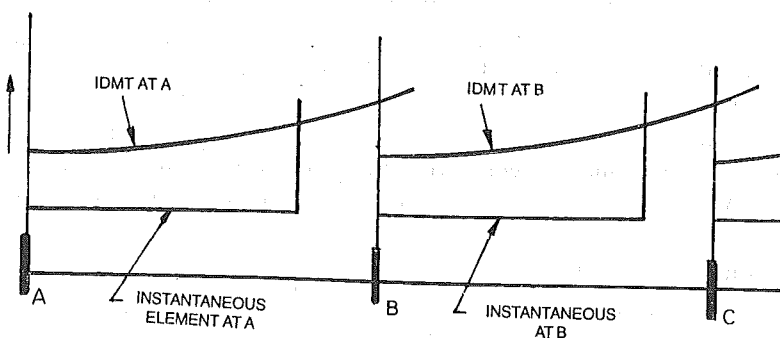

Fig. 30.6 (a) Characteristics of the combined instantaneous and IDMT protection.

30.6. DEFINITE TIME OVERCURRENT PROTECTION OF LINES (Fig. 30.7)

Definite time overcurrent relays have adjustable overcurrent elements. When an element picks up it energizes a built-in time element, which initiates a tripping signal after the elapse of the preset time.

The tripping times are so graded that the relay beyond the remote station (C) is set at a shorter time than the relays nearer to the power source. This form of time grading is satisfactory for simple line configurations with single-end in-feed provided that the tripping times at the power source do not become excessively long. Definite overcurrent protection is also employed as back-up protection for generators and transformers.

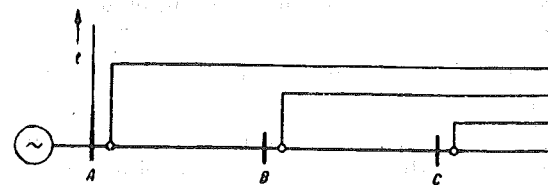

Fig. 30.7. Time graded overcurrent protection with definite time relays.

30.7. EARTH FAULT PROTECTION OF LINES

The general practice is to use a set of two over-current relays for protection against interphase faults and a separate overcurrent relay for single line to ground fault. Separate ground fault (earth fault relays) are generally preferred because they can be adjusted to provide faster and more sensitive protection for single line to ground faults than that provided by the phase (Refer Ch. 27).

Earth-fault currents depend on type of natural earthing. Where no natural point is available, grounding transformer is used.

In case of resonant earthed system or ungrounded systems, the earth-fault currents are minimum (Ref. Ch. 37). Hence conventional earth-fault protection by residual earth-fault relays cannot give a satisfactory protection. Hence a double actuating quantity earth-fault relay is provided at each station. In addition, a directional element is provided to determine in which feeder is the earth-fault. The double actuating quantity relay has one voltage coil energized by residual voltage and current coil energized by residual current.

In case of resistance earth or solid earthed systems, the over-current element connected in residual circuit of CTs is preferred.

The setting of earth-fault relays may be made less than rated full load current of the line.

The earth-fault elements are with inverse characteristics and time-grading is preferred for earth-fault protection of radial feeders.

The practice followed is to apply relays having a setting range of 10 to 40%. A setting of 10% on a 500/5 A ; current transformer means the relay operates for primary earth fault current of

$$\frac{500}{5} \times \frac{10}{100} = 5 \text{ A.}$$

Selection of optimum setting of earth fault relay is difficult. The final setting is determined by test before commissioning.

The procedure for time setting is similar to that of overcurrent relays. However the errors are calculated for each current level and corresponding relays time should be considered.

Directional earth fault relays are used where fault power can be supplied from both ends of protected equipment. Fig. 30.4 illustrates the time graded scheme of ring main based on direction earth fault protection.

30.8. SUMMARY OF OVERCURRENT PROTECTION OF LINES

Overcurrent protection of lines falls into following categories :

- Graded time lag overcurrent protection. In this protection, inverse time relays are employed. This time settings of over-current relays at successive stations are so graded that discrimination is obtained.
- Graded time lag or graded that directional overcurrent protection.
- This is employed where power flow can be from either sides and simple overcurrent protection does not provide selectivity.
- Protection by instantaneous overcurrent relays.
- Protection by definite time overcurrent relays.
- Separate relays are provided for phase fault protection and earth fault protection. The relays for phase fault protection are co-ordinated independently of relays for earth fault.

PART 30B. DISTANCE PROTECTION OF TRANSMISSION LINES

30.9. INTRODUCTION TO DISTANCE PROTECTION OF H.V. AND E.H.V. LINES (Ref. Ch. 29, Ch. 42)

Distance relaying is considered for protection of transmission lines where the time-lag cannot be permitted and selectivity cannot be obtained by overcurrent relaying. Distance protection is used for secondary lines and main lines.

A distance relay measures the ratio $\frac{V}{I}$ at relay location which gives the measure of distance between the relay and fault location. The impedance (resistance/reactance/admittance) of a fault

loop is proportional to the distance between the relay location and the fault point. For a given setting, the distance relay picks up when impedance measured by it is less than the set value. Hence it protects a certain length of line. Hence it is called distance relay.

Measurement. Considering zero fault impedance the voltage at fault point will be zero. The voltage at relay location O will be equal to the voltage drop along the length OF , whereas same current I is flowing in the line at O upto F . If fault had occurred near O , the voltage at O would be different. Current would be more because of the reduction in line impedance. If fault occurred away from O , the voltage at O would be lesser and current would also be lesser. In distance relays the ratio V/I is measured. The current gives operating torque and voltage gives restraining torque. Hence for values of Z above certain setting the relay does not operate. Hence it protects only a certain length of line equivalent to its Impedance setting.

For the impedance measurement there several possibilities however, for distance protection equipment the impedance $Z = V/I$ or the conductance $G = (I/V) \cos \phi$ are generally measured. When planning impedance-dependent protection schemes particular attention must be paid to the influence of the arc resistance on the loop impedance. This arc resistance has ohmic nature and increases the circuit impedance of the short-circuit loop. This falsifies the measurement of impedance by the protection equipment as regards both magnitude and phase relation.

Allowance must be made for the effect of arc resistance when setting the protection equipment. The resulting tripping characteristics represent a modified value between the impedance and conductance measurement. Modern distance protection relays include provisions for matching the degree of arc compensation to the short-circuit angle of the line depending on the application.

The arc resistance is approximately given by

$$R_{arc} = \frac{3 \times 10^4 L}{I^{1.4}}$$

where R_{arc} = resistance of arc, Ohms

L = Length of arc in metres in open standstill air

I = Fault current Amperes.

Due to the extra arc resistance the distance measured by the impedance relays is inaccurate. The distance relay will measure in impedance $Z_f + R_{arc}$, where Z_f is impedance of line.

For short lines, the Z_f is relatively low and R_{arc} is not negligible. Hence measurement of impedance $Z = Z_f + R_{arc}$ does not give accurate measure of distance. For long lines, the R_{arc} is negligible compared with Z . Hence measurement of impedance gives fairly accurate measurement of distance.

A sudden change in loading condition in a power system causes power swings between load point and source. Under certain circumstances, the power swings can cause the operation of distance relays. Hence it is desirable to examine the behaviour of distance relays during power swings.

The principle of measurement in following types of distance relays was described in Ch. 29 :

- | | |
|---------------------------|---------------------------------|
| — Plain Impedance Relay | — Directional Impedance Relay |
| — Mho type distance Relay | — Reactance type distance Relay |

The application of such relay in practical distance schemes are discussed in this chapter. There is no hard and fast rule regarding these applications. There is overlapping in many areas of applications. (Static Distance Protection : Ch. 42)

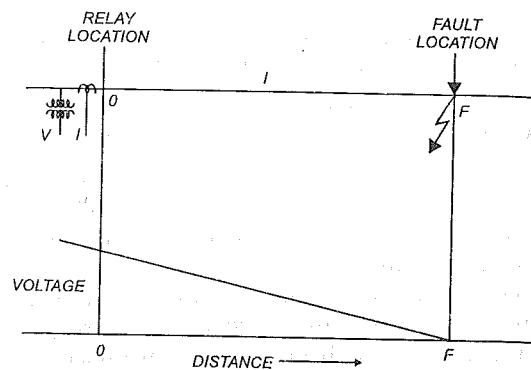

Fig. 30.8. Distance relaying : measurement of distance.

30.9.1. Plain Impedance Protection (Ref. Ex. 42.1)

Fig. 30.9, the plain impedance relay does not recognize the direction in which the fault has occurred. Relay is Non-Directional. Hence it will operate for all faults along the line BC and also along BA provided the impedance measured by relay Z_B is less than the setting.

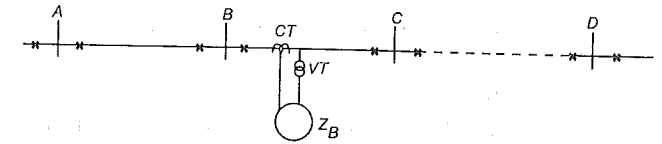

Fig. 30.9. Explaining Impedance Protection.

The relay unit can be high speed (instantaneous) or with time increasing with measured impedance.

The relay will not only operate for faults on section BC but also faults in section AB and faults on busbar in station B . Therefore, discrimination between faults on neighbouring sections is not possible with plain impedance protection.

Plain impedance relay has three major disadvantages :

- Selectivity cannot be obtained as it operates for faults on either sides. Circle covers all four sectors.
- As it measures resistance and reactances, it is affected by resistance of arc, resistance of transmission line.
- It is affected by power swings (fluctuation of reactive power) as the circular characteristic covers a large area on every side of centre wing point comes within circle.

Ref. to Fig. 30.9 for faults near C , in the line BC , the relay at B cannot accurately discriminate between fault in CD and fault in BC . The fault resistance will be seen by relays as extension of line length, thereby the relay set for protecting line BC will not operate for faults very near C . This is called *under reach*. Fault resistance is a horizontal line segment on R - X diagram (Fig. 30.14). For a fault near C (Fig. 30.10), such segment will take measured point beyond the circle. Therefore the relay will under-reach (Defn. Sec. 25.8.)

It is a standard practice to set the reach of the first zone of distance relay to cover only about 85% of protected line impedance (Ref. Fig. 30.11).

30.9.2. Directional Impedance Relay

For achieving discrimination between forward and rear faults, the directional impedance relays are used. Directional impedance protection acts only for faults in forward direction. This is explained in Fig. 30.12.

The directional impedance relay Z_B does not operate for faults in zone BA and for faults on busbar B .

Directional Impedance Relay combines the directional element and impedance measuring element in a single case.

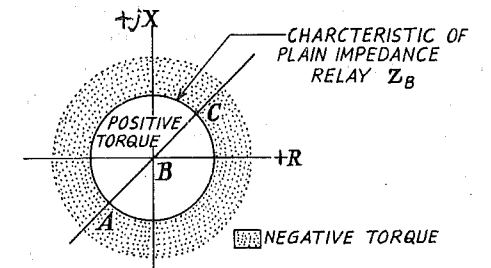

Fig. 30.10. Explaining Plain Impedance Protection.

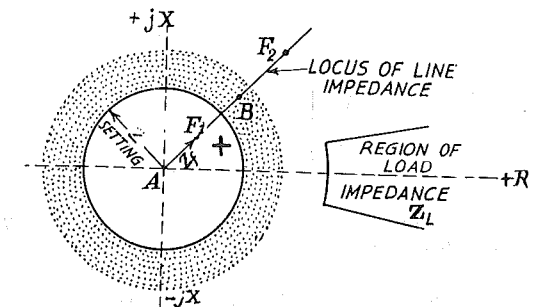

Fig. 30.11. Impedance Relay at 'A' to protect 85% of line AB.

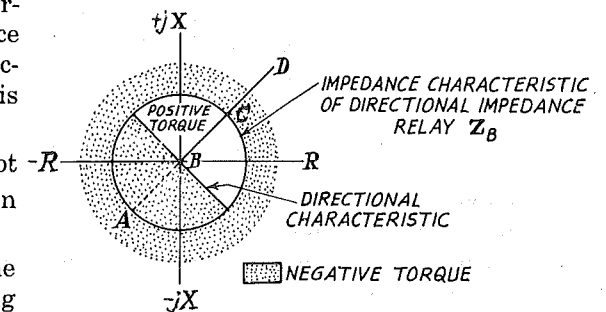

Fig. 30.12. Directional Impedance Relay Characteristics.

The voltage supplied to the directional element is taken from the two phases from which current is not taken. Thereby the function of directional element is not affected by drop of voltage.

Directional Impedance Relays are preferred for phase fault protection of lines of moderate lengths.

30.9.3. Reactance Relay

The main advantage of reactance relay is that is not affected by fault resistance. The characteristic of plain reactance relay is a line parallel to R -axis in R - X plane. However, the reactance relay is not used by itself. It is generally used along with Mho Relay or offset Mho Relay.

Suppose reactance relay is used along with Mho Starting Relay (Fig. 30.13). The reactance relay measures reactance upto fault point. The voltage drop due to arc (AB) does not affect the measurement, as all points on AB are in operating region.

Hence such relays are used for protection of short lines having fault currents less than 20 KA. In such lines the effect of fault resistance is predominant.

In case of long lines, the effect of arc resistance is negligible.

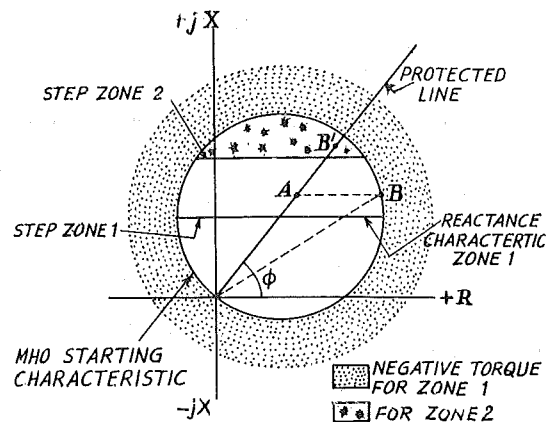

Fig. 30.13. Combined Characteristics of Mho Starter and Reactance Relay.

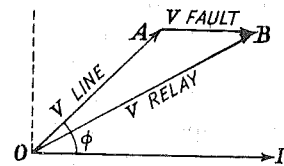

Fig. 30.14. Relay measures Line voltage plus fault voltage.

30.9.4. Mho Relay Admittance Relays (Ref. Sec. 42.14 b)

Mho characteristic is a circle passing through origin of R - X diagram (Fig. 30.13) Mho relay preferred for phase fault relaying of long lines particularly where severe synchronizing power surges can occur. (Fig. 30.15)

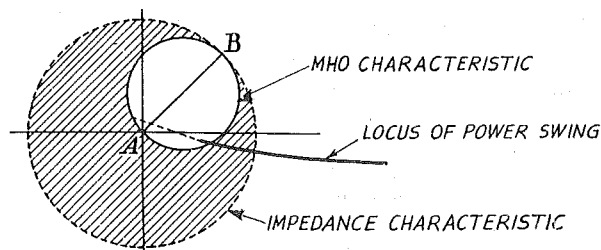

Fig. 30.15. Comparison of Mho characteristic and impedance characteristic under conditions of Reactive Power Swings.

Comparing to impedance characteristic (for protecting line AB), the Mho characteristic requires very much less area. Hence many points covered by impedance characteristic are in the negative torque region of Mho characteristic (Figs. 30.15 and 30.16).

Hence Mho relay can remain inoperative during power swings on EHV lines to a greater extent than impedance relay.

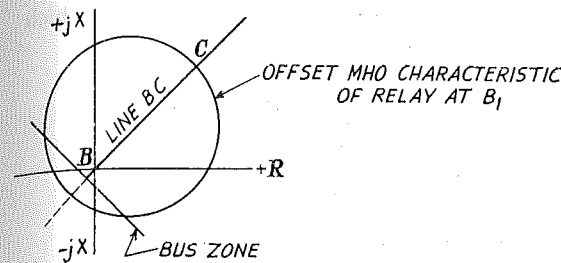

Fig. 30.16 (a) Off-set Mho characteristic to cover bus-bar zone.

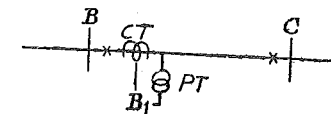

Fig. 30.16 (b).

30.9.5. Offset Mho Characteristic (Ref. Sec. 42.7)

The offset Mho characteristic encloses the origin of R - X axis. The main applications off-set Mho relay are following :

- Bus bar back-up protection
- Carrier starter unit in carrier Aided Distance Blocking Schemes
- Power Swing Blocking

Referring to Fig. 30.16 the Mho characteristic at B_1 is offset so as to enclose origin B and cover the bus bar zone at B .

(Hatched Area indicates that impedance characteristic has much more of +ve torque region which is beyond that of Mho characteristic).

Referring to Fig. 30.17 during the power swing locus of impedance measured by relay moves along the curve. As soon as it comes within the positive torque region of the offset Mho characteristic (Point P , the offset Mho relay acts and blocks the measuring relay for line BC . Therefore, the relay does not operate during power swings. (Details about Power Swing : Sec. 42.9)

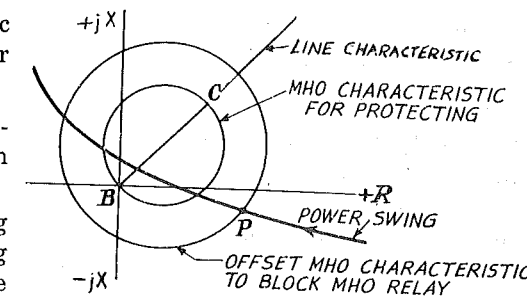

Fig. 30.17. Blocking during power swings.

30.10. DISTANCE SCHEMES

Distance schemes comprise set of protective systems. The choice of Distance scheme depends upon

- distance between relaying points, number of stations in series
- speed of operation desired.
- system configuration.
- other protections provided for the line.
- whether directional feature necessary
- whether high speed auto-reclosure provided.
- stability considerations, etc.

There are several alternative schemes from which choice is made. The schemes may be divided into the following three broad groups:

1. Distance schemes designed for phase faults only.
2. Non-switched schemes for phase faults as well as earth faults.

Such schemes have separate distance relays for phase faults and earth faults. Thus such schemes have several measuring elements.

3. Switched schemes having a single set of measuring element (for all kinds of fault) to which an appropriate measured quantity is applied according to type of fault.

4. Static distance schemes (Ref. Ch. 42.)

Distance schemes comprise the following components :

- | | |
|---------------------|----------------------|
| — starting elements | — measuring elements |
| — zone timer | — tripping relays. |

30.11. STARTING ELEMENT (FAULT DETECTORS)

Starting Elements are used with distance schemes having one or more measuring elements. The tasks of starting elements are the following :

- To switch the measuring element to correct input quantity, depending upon type of faults, in case of distance relay with single measuring element.
- Selecting of correct phase for tripping instructions, if single phase auto reclosure is used.
- Changing distance steps or reversing the direction of measuring element after a certain time lag.
- To give non-directional back-up to measuring elements.
- To prepare carrier equipment to receive a possible instruction.

The **starting element** also called fault detector acts first and switches the **measuring element** to appropriate input quantity.

In switched schemes, there is only a single measuring element which is switched to appropriate phase by starting element and their auxiliaries, depending upon the type of fault. The choice of scheme is made from standard schemes (examples in Table 30.1). In non-switched schemes, for each type of fault there is separate measuring element.

Types of Starting Elements

- | | |
|------------------------------|---------------------------|
| — Overcurrent Starters | — Undervoltage Starters |
| — Impedance Starters | — Minimum Impedance type. |
| — Compounded Impedance type. | |

In the event of a fault the starting elements will operate first and apply the secondary voltage and current of the faulty phase or phase to the measuring element.

For the majority of applications overcurrent starting will be adequate, but where required, for example in a resistance earthed system, undervoltage starting can be added.

When impedance starting is required (see above) the over-current and undervoltage elements are replaced by the impedance starting-elements. These are normally connected to select correctly the faulty phase in the case of phase faults. In the case of an earth fault, the connections of the three impedance starting-element are switched by means of the residual-current starting element to select correctly the faulty phase.

Minimum Impedance Starters

As starting element of distance relays in e.h.v. system minimum-impedance relays are preferred because the minimum short-circuit current in such system at low loads is often less than the maximum service current at peak load. The minimum impedance relay compares the voltage and the current ; its functional principle being described in Figs. 30.18 and 30.19.

For the protection of long and/of heavily loaded ones, the voltage applied to minimum-impedance relays can be compounded to enable the starting elements to earth further along the line. At the same time a much heavier load can be carried without the starting elements picking up.

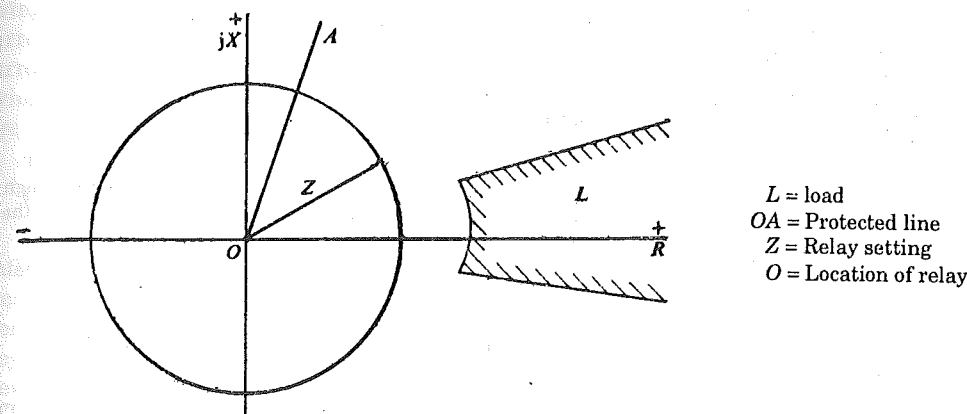

Fig. 30.18. Characteristics of an impedance relay on R-X plane.

30.12. STEPPED CHARACTERISTIC

The distance relays of early day used to have Inverse characteristic of Distance vs. Time. Now such characteristic is no more preferred and distance relays have *stepped characteristic*.

The stepped characteristic may be either single stepped (Fig. 30.11) or three stepped, (Fig. 30.12).

Single Stepped Distance-Time Characteristic

Single step distance relays can be used where high set instantaneous overcurrent relays cannot be used. The typical applications of single-step distance protection are protection of transformer feeder, protection of single section transmission lines, protection of bus bars etc. The conventional distance measuring element has instantaneous time-distance characteristics. The operating time becomes infinite at relay reach point. The distance relay is set for a value say Z corresponding to length of line L . Then if a fault occurs within length L , the ideal distance relay operate instantaneously.

However the d.c. component of wave, fault resistance, influence the relay measurement and cause over-reach or under reach.

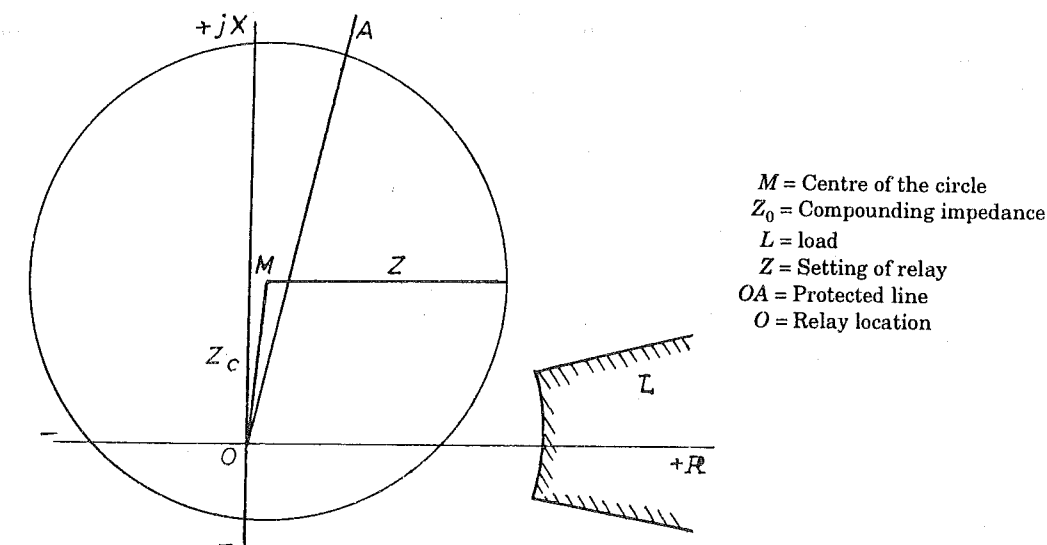

Fig. 30.19. Characteristics of a modified impedance relay in the R-X plane.

Over-reach. When short circuit occurs, the current wave has d.c. component which causes a distance relay to over-reach, i.e. to operate for a large impedance than desired. The tendency to over-reach is minimized by adjusting the voltage to 90 to 80% of its normal value.

Effect of arc resistance, Under-reach. The arc resistance is approximately given by

$$R_{arc} = \frac{2.9 \times 10^4 L}{I^{1.4}}$$

where R_{arc} = Resistance of arc, Ohm

L = Length of arc in m. in open standstill air

I = Fault current Amperes.

Due to the extra arc resistance the distance measured by impedance relays inaccurate. The distance relay will measure an impedance $Z_f + R_{arc}$, where Z_f is impedance of line.

By adding Z_f and R_{arc} the measured point on R - X diagram goes out of impedance circle and relay does not operate even though the fault is within the protection zone. This is called *Under-reach*.

30.13. THREE STEP DISTANCE-TIME CHARACTERISTIC

The transmission lines having successive line sections can be protected by means of three-zone distance protection schemes. By such schemes, quick protection can be obtained and back-up of the sections as well as adjoining lines/bus bars can also be provided.

Referring to Fig. 30.12, the distance relay R_A , located at section A has a 3-step characteristic given by dashed line marked tA_1, tA_2, tA_3, tA_1 , is called the first step and covers about 80 per cent of the first line section AB, and gives instantaneous protection. tA_2 is the second step of relay at station A (R_A) and covers the remaining portion of section AB and about 20 to 50 per cent of the next section (BC). The third step having timing tA_3 covers the entire remaining line. The steps are obtained by one of the following methods :

- Changing taps on auxiliary voltage transformer,
- Switching resistance in relay restraint circuit at pre-set time intervals by means of time-element.
- Separate measuring element for zone 2 and zone 3.

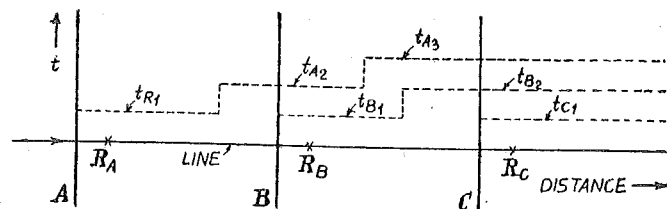

AB = Section I
Beyond C = Section III
RA, RB, RC = Relays
 t_{B1}, t_{B2} = Times RB stages.

BC = Section II
A, B, C = Stations
 t_{A1}, t_{A2}, t_{A3} = Times of RA stages
 t_{C1} = Times of RC stages.

Fig. 30.12. Three step characteristic of distance relay.

30.14. POWER SWINGS (Ref. Sec. 42.9)

Sudden change in load conditions in the system cause power swings between the load and generating station. The starting elements (*SE*) in distance scheme generally respond to power

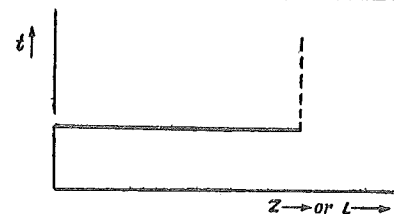

Fig. 30.11. Single-step characteristic of high speed impedance relay : above certain Z , the relay is inoperative.
For smallest Z the relay operates in time t_1 .

swings. Overcurrent *SE* is readily affected. During power swings, there is a heavy flow of equalizing current in transmission lines, current caused by swing flows equally in all phases causing the overcurrent *SE* to pick up in all phases. Minimum impedance *SE* responds to ratio V/I . During power swing, voltage also drops at certain points of the system in addition of equalizing currents. Therefore, such starting relay of all three phases can pick up during heavy power swing.

Thus overcurrent *SE* or impedance *SE* operate during power swings.

Hence the measuring element (*ME*) has to decide whether to operate the relay or to block it.

In general distance relays having mho characteristic are less susceptible to power swings because of their narrow characteristic. Generally during power-swings an out-of-step blocking relay operates. If measuring element operates within a certain time after operation of blocking relay, then tripping is allowed. Modern distance relays are stable over a wide range of power swings, they do not trip unselectively, if power swing reverts to normal condition fairly soon. If the condition prevails, the relay trips (Ref. Sec. 30.8.5.)

30.15. CARRIER ASSISTED DISTANCE PROTECTION (Ref. Sec. 30.19)

While protecting a transmission line the following are the desirable features :

- Simultaneous opening of circuit-breakers at both ends of the line for internal faults.
- Simultaneous reclosure.
- Discrimination between internal and external faults.
- Single pole switching.
- Independent phase relaying, etc.
- Distance relays are used in conjunction with carrier channel.

30.15.1. Carrier Transfer (Intertripping)

Carrier signal is transmitted to the other end of the section to bring about simultaneous tripping of the line-section. This is called Transfer trip or Intertrip technique. After the tripping, the auto-reclosure relays takes over.

With stepped time-distance characteristics of distance relays, the first distance step (R_A) is generally to cover about 80 per cent of first line section. The relay at remote end (R_B) is arranged in a similar way, but in opposite direction (Fig. 30.13).

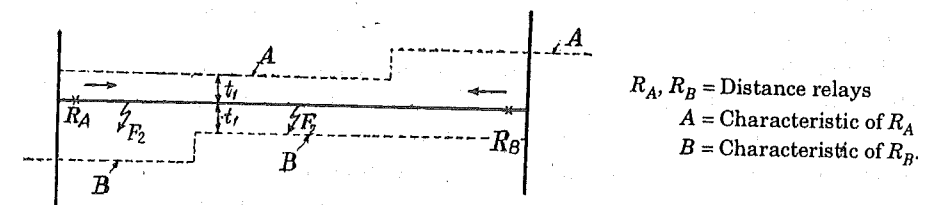

Fig. 30.13. Explaining Carriers Transfer.

Carrier transfer is explained by means of Fig. 30.13. If fault occurs in the middle of the section, the distance relays at both end (R_A and R_B) will trip with time t_1 of the first step. However, if the fault occurs near the end of the line section, (say F_2 near R_A), the relay at P remote end (R_B) will operate with time t_2 whereas relay at local end (R_A) will operate with time t_1 resulting in non-simultaneous operating of circuit-breakers at both the ends. This is not desirable from stability and auto-reclosure considerations.

The nearer relay (R_A in this case) is therefore, made to send a carrier signal to the remote end (R_B) to bring about simultaneous tripping of the circuit-breakers at both ends. After operation of the relays and circuit-breakers, auto-reclosure relay takes over.

The scheme for carrier transfer is illustrated in Fig. 30.14. The relay step 1-circuit initiates the transmission signal sent by the carrier transmitter via the line Fig. 30.14 (b). The step 1 relay S_1 initiates the carrier transfer in addition to completion of the trip circuit at local end. A similar set arrangements are provided the remote end.

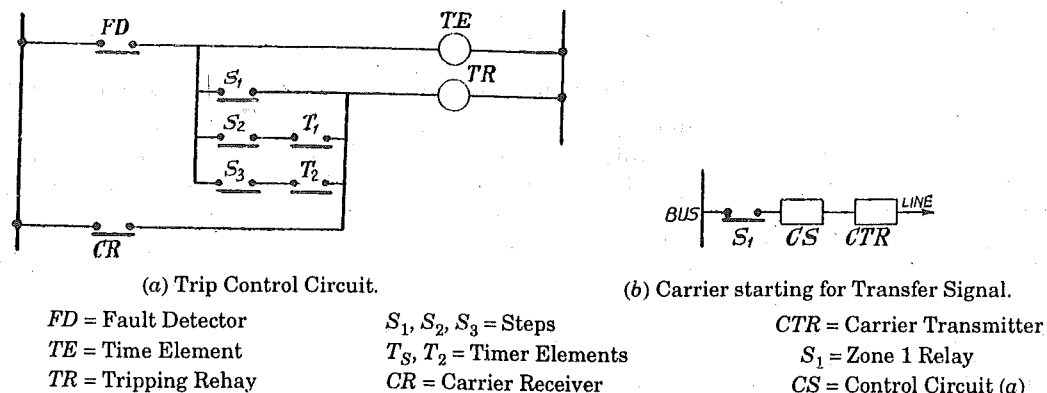

Fig. 30.14. Scheme of carrier receiver transfer relaying.

30.15.2. Carrier Blocking Scheme (Directional Comparison Method)

In this case the distance step is arranged to over-reach. Provision is made to prevent the tripping of the circuit-breakers for faults on next section.

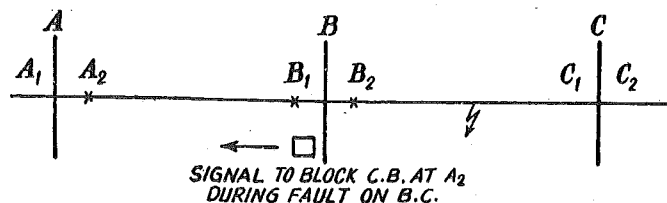

Fig. 30.15 (a) Directional comparison, or Carrier Blocking.

The principle is as follows : "The direction of fault power at two ends of the protected line is compared by means of directional relays. Under internal fault conditions the direction of the fault power must be outwards at one end and inwards at the other end. Under through fault condition the fault must be fed into the line at only one end. (Ref. Fig. 43.13)

The primary protection is given by distance relays. The directional comparison relaying operates in conjunction with the distance relays.

When fault power is flowing outward from the line at one end, the directional relay at that end actuates a carrier signal which block at its local end and at the other end. Suppose fault occurs in adjacent line BC.

The directional relay at B_1 will actuate and it will send signal to station A. Thereby the tripping of CB's at A_1 and B_1 is blocked. If short circuit occurs in the section AB no signal is sent to block tripping A_2 and B_1 .

Thus carrier signal is sent only during fault conditions.

Depending upon the kind of distance relay, various circuit arrangements may be used. During fault on BC very near to B_2 , the distance relay at A_2 will start as it is set with an over-reach of about 20% over the length AB. However, a time delay is provided such that a relay at the A_2 does not operate earlier than receiving blocking signal. If no blocking signal is received, the fault is internal for zone AB and relay at A_2 operates. Thus carrier blocking schemes should have a slight time delay for their first step. By using first blocking signals, this time delay can be cut down. Carrier Blocking schemes have an advantage that the signal is transferred over healthy line.

30.15.3. Carrier Acceleration

In this scheme, a signal received from a relay at opposite end is used to extend the first step from about 80% to about 150% of the reach (length of the protected line) by shunting the timer element of zone 2. The contacts of timer of zone 2 relay are shunted by normally open carrier receiver relay contacts. Thus all faults within protected section can be cleared approximately at the time of first zone. Fig 30.16 explains this principle. For faults near B, in section AB, a carrier timer is shunted. Thereby the second zone time is reduced from tA_2 to tA_1 . A similar characteristic (not shown) is provided at B in direction BA.

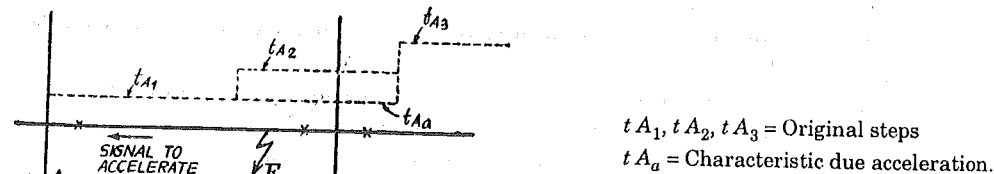

Fig. 30.15 (b) Carrier Acceleration.

30.16. DISTANCE SCHEMES FOR SINGLE POLE AND TRIPLE-POLE AUTO-RECLOSING (Ref. Sec. 44.8)

Distance relays can be arranged in conjunction with single phase or three phase auto-reclosure. In case of switched schemes, the pole selection is made by starting element auxiliaries. In non-switched schemes, it is provided by respective phase measuring elements and their auxiliary elements. However all the three measuring elements may be tripped to ensure whether the fault is on more than one phase.

30.17. CONNECTIONS OF DISTANCE RELAYS

Distance Relays are connected in the secondary circuit of CT's and VT's. The connections should be such that the impedance measured by the relay should be proportional to the distance between relay location and the fault, for all types of faults.

The voltage supplied to relay coil (V_r) must be proportional to the voltage drop upto fault point. The current supplied to relay coil (I_r) should be proportional to fault current. To achieve this, the distance relays should be connected such that they cover the fault loop.

- In three phase systems the faults can be
- phase to phase fault.
- phase to earth fault
- Double phase to earth fault.
- Three phase fault.

Phase to phase fault can occur between R—Y, Y—B, B—R. To cover these faults, distance relay should have three measuring elements (in one casing). Alternatively, a single measuring element switched over to appropriate voltage and current. Fig. 30.16 illustrates a typical connection for phase fault protection. In this scheme there are three measuring elements.

The current coils are connected in star to three secondaries of line CT's. The voltage coils are connected in delta across secondaries of line VT's.

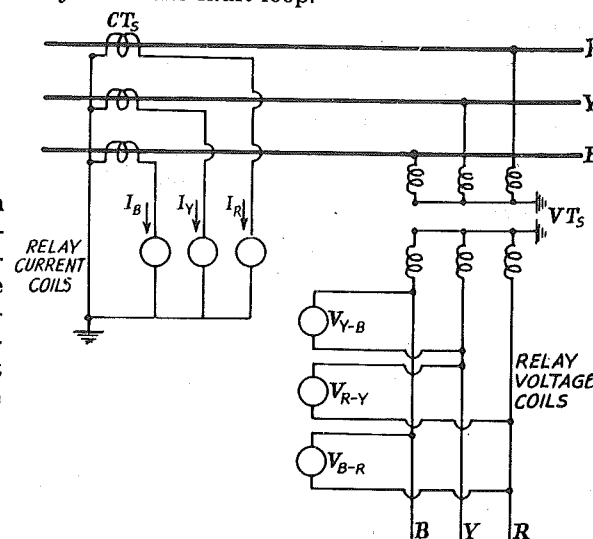

Fig. 30.16. Connections of Distance Relay for Phase Faults.

Connections of distance Earth fault relay (Not shown) are different from the Distance phase fault relays.

PART 30C. PROTECTION OF LINES BASED ON UNIT PRINCIPLE

The unit protection responds to internal faults only. The use of channel to compare conditions at the terminals of a power line, provides the only selective means of high-speed clearing of end zone faults. In many ways pilot protection is analogous to differential protection of buses, transformers and machines.

The advantages of high speed simultaneous clearing of all terminals are :

- Limits the possibilities of conductor burn down due to over-loading and in general minimizes damage to the line.
- Improves transient stability of system by quick disconnection of faulty line.
- Permits high speed reclosing, which is successful, will improve transient stability or minimize outage time or poor voltage conditions on portions of the system load (Refer Ch. 44)

Unit type feeder protection includes pilot wire protection and carrier current protection. Merz-Price or differential circulating current protection was widely used in U.K and U.S.A. In earlier years d.c. pilot schemes were used. Now they are replaced by A.C. pilot schemes discussed in this section.

30.18. PILOT WIRE PROTECTION USING CIRCULATING CURRENT DIFFERENTIAL RELAYING

The differential circulating current protection principle can be readily applied to feeder protection.

Two CT's are connected in each protected line, one at each end. Under healthy/external fault conditions the secondary currents are equal and circulate in pilot wires. The relay is connected between equipotential points of pilot wires. For external faults and normal condition the differential current $I_1 - I_2$ of two CT's is zero and relay does not operate. During internal faults this balance is disturbed and differential current flows through the relay operating coils.

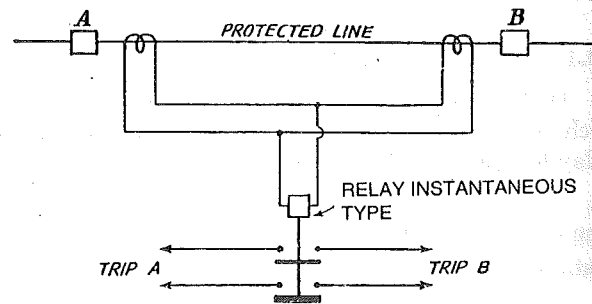

Fig. 30.17. Pilot wire protection of line.

The circuit-breakers at two ends separated by a long distance, there is a need to have relaying going at each end associated circuit-breaker. In line protection (Fig. 34.17), relaying point falls in the middle of the line. This means added difficulties.

To solve this problem the circuit is modified (Fig 30.18) by providing two relays, one at each end.

Another method (Fig. 30.19) is by using split pilot principle which uses a three core cable as pilot.

Pilot wire Relaying using voltage balance. In this method the secondary currents are replaced by or converted to an equivalent voltage source of fairly low impedance. The equivalent at two ends are compared as shown in Fig 30.20. For healthy condition, no current flows through

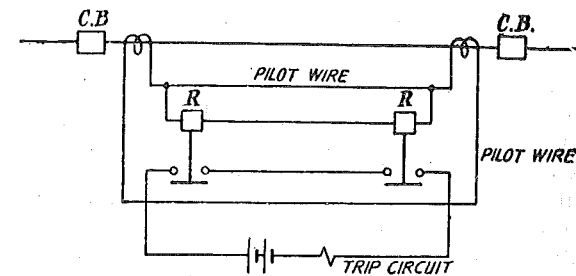

Fig. 30.18. Use of two relays, one at each end.

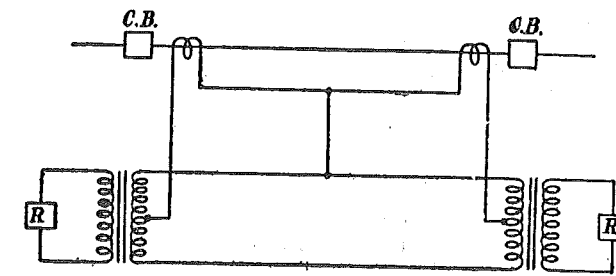

Fig. 30.19. Pilot wire relaying with split pilot connection using 3-core cable for pilot connections.

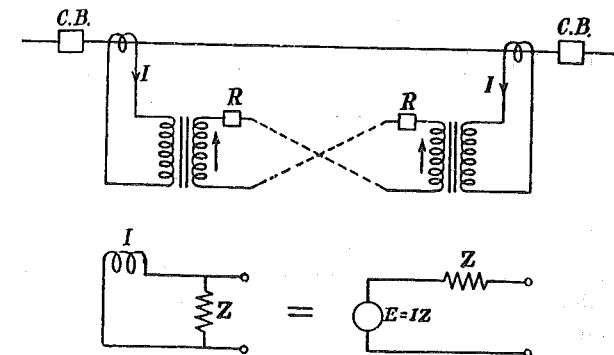

Fig. 30.20. Principle of voltage-balance.

the relay coils. During internal fault current circulates through relay coil. Voltage balance system is basically a differential system (Ref. Sec. 28.7).

Discriminating Factor. Operating current at one terminal or an internal fault to an external fault with same primary current applied from that terminal.

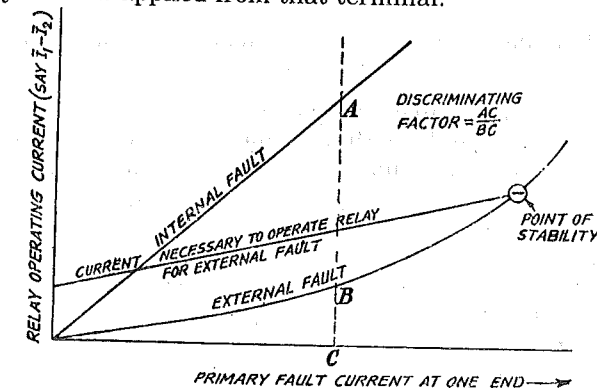

Fig. 30.21. Discrimination factor.

Referring to Fig. 30.22, consider a current differential scheme.

Let I_o be relay operating current, I be the primary current at one end. Keeping primary current I the same, let I_{OI} be the current in relay for internal fault and I_{OE} be current in relay for external fault. Then I_o is plotted against fault current. The ratio of I_{OI} and I_{OE} gives discrimination factor. It is observed that beyond a certain value of fault current, the relay loses stability and operates for external faults. (Ref. Fig. 30.12—Point of Stability)

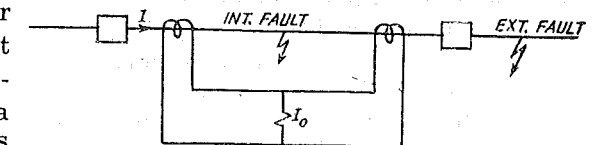

Fig. 30.22. Current differential scheme.

Transley System. This is based on differential balance voltage principle. It has telephone lines as pilot wires. Advantages of higher currents can be used. Arrangement consist of induction relays at either ends. Schematic diagram is shown in Fig. 30.23.

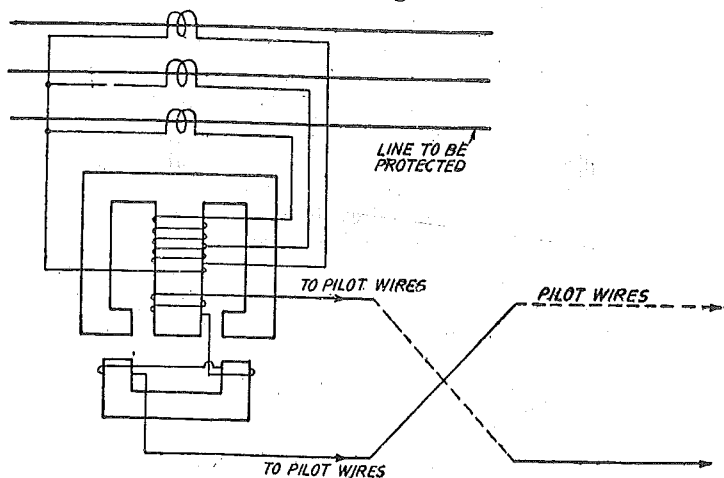

Fig. 30.23. Transley system of balance voltage protection.

Limitations of Pilot Wire Protection of Line. Pilot wire protection needs additional expenditure of Pilot wires, the Pilot wires need supervision to check. Open circuits and short circuits on Pilot wires lead to relay failure.

The Pilot wires are put at the same time along with power conductors. In cable systems, Pilot cables are put in the same trench of power cable.

For short lines of less than 16 km the Pilot wires give most economical form of high speed relaying. For lines upto 16 km Pilot wire protection is popular. It used even for lines upto 50 km. in rare cases. Beyond the length of 16 km. carrier current Pilot relaying is more economical and preferable.

Voltages are induced in pilot wires due to the field of power conductors. This voltage should be limited to 5—15 volts.

Overhead Pilot wires are exposed to lightening and high voltage surges. They must be protected by means of lightning arresters. Similarly they should not come in contact with power circuit. According to the rules the voltage across Pilot is limit to about 200V and current to 200mA.

Pilot Supervision. If Pilot circuit opens or shorts, relaying system fails. The effect as follows :

Pilot fault	Circulating current scheme	Balanced voltage scheme
Short circuit	Fails to trip for internal faults.	Trip on full load.
Open circuit	Trip on full load.	Fails to trip on internal faults.

To avoid this trouble, automatic supervision is usually applied along with overcurrent fault detectors to prevent wrong tripping.

Summation Circuits

The need to economize in the pilot cores has resulted in the use of current summation devices so that the polyphase line currents may be reproduced as a single-phase quantity. This enables the comparison over the pilot channel to the effected on single phase basis and the pilot cores to be reduced to a minimum of two.

Most summation devices include transformers and can, therefore, be used to reduce the burden imposed by the Pilots on the current-transformer by changing the impedance levels. A further advantage is the possibility of isolating the current-transformers from the Pilots. This enables the current-transformers to be earthed and the Pilots to be without earth.

Summation-transformers

The most common device in use is the "Summation-transformer", which is shown in its simplest form in Fig 30.24. A common primary-winding is connected to the line current-transformer outputs, each phase energizing a different number of turns, from line to neutral. The arrangement gives an equivalent secondary output for the various types of fault, as shown by the table of Fig 30.24 ; these can easily be derived for any tapping arrangement by construction of the equivalent ampere-turn vector diagram. Such devices are not perfect as there are complex fault-conditions, such as 2 : 1 : 1 fault-distribution on Y-B-R phase with equal R-Y and Y-B sections, which will give no output. Another example of the limitations of summation transformers is a double earth fault with a resistance earthed neutral. In the ratio of phase fault current to earth fault current is of the right order, it is possible with some double earth-fault, for the output to be zero or very small.

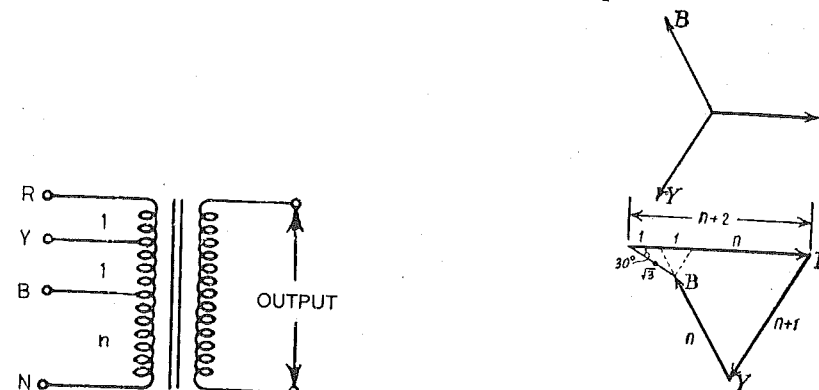

$R-N = n + 2Y-N = n + 1$ $B-N = n$
 $R-Y = 1$ $Y-B = 1$ $B-R = 2$
 $3\text{-phase} = \sqrt{3}$

Equivalent output for Equal fault-current.

Fig. 30.24. Summation-transformer.

SEC. 30D. CARRIER CURRENT PROTECTION OF TRANSMISSION LINES.

30.19. CARRIER CURRENT PROTECTION

This type of protection is used for protection of transmission lines Carrier currents of the frequency range 30 to 200 kc/s in USA and 80 to 500 kc/s (kHz) in UK are transmitted and received through the transmission lines for the purpose of protection.

The schematic diagram of carrier current protection is given in Fig. 30.25.

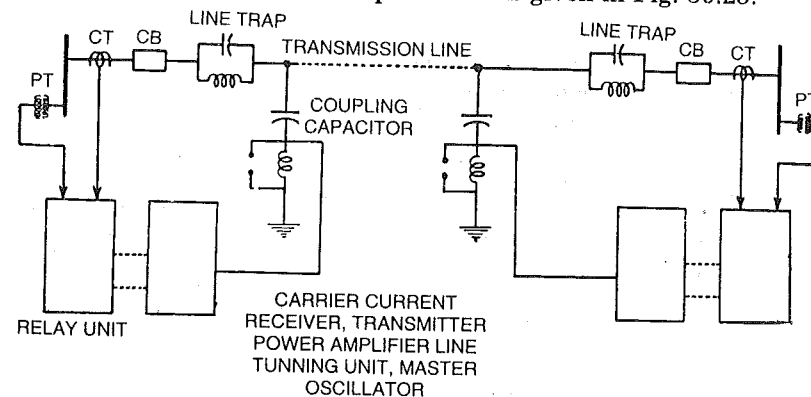

Fig. 30.25. Scheme of carrier current relaying.

Each end of the line is provided with identical carrier current equipment consisting of transmitter, receiver, line-tuning unit, master oscillator, power amplifier, etc.

1. Coupling capacitor. The carrier equipment is connected to the transmission line through 'Coupling Capacitor' which is of such a capacitance that it offers low reactance $\left(\frac{1}{\omega C}\right)$ to carrier frequency but high reactance power frequency. For example, 2000 pF capacitor offers 1.5 megahms to 50 Hz and 150 ohms to 500 KHz.

Thus coupling capacitors allows carrier frequency signals to enter the carrier equipment but does not allow 50 Hz power frequency currents to enter the carrier equipment. To reduce impedance further a low inductance is connected in series with coupling capacitors to form a resonance at carrier frequency.

2. Line Trap Unit. Line trap unit is inserted between busbar and connection of coupling capacitor to the line. It is a parallel tuned circuit comprising L and C . It has a low impedance (less than 0.1 ohm) to 50 Hz and high impedance to carrier frequencies. This unit prevents the high frequency signals from entering the neighbouring line, and the carrier currents flow only in the protected line.

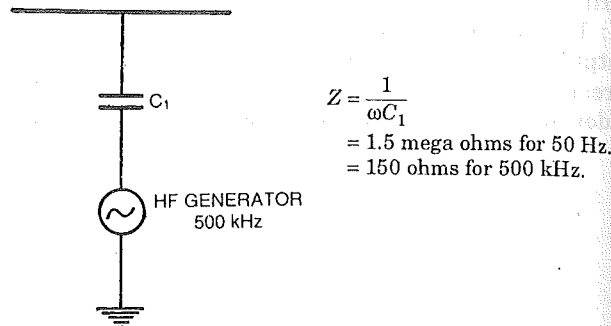

Fig. 30.26. Function of coupling capacitor.

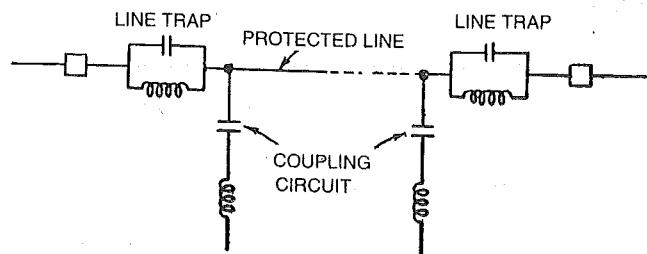

Fig. 30.27. Line Trap Units.

3. Protection and Earthing of Coupling Equipment. Overvoltages on power lines are caused by lightning, switching, faults, etc. produce stress on coupling equipment and line trap unit. Non-linear resistors in series with a protective gap is connected across the line trap unit and inductor of the coupling unit. The gap is adjusted to spark at a set value of overvoltage.

Base of coupling unit is earthed by earth rod in the vicinity to obtain low earth-resistance. Carrier panel usually installed in relay room is connected to station earthing system.

4. Electronic Equipment. There are generally identical units at each end :

(i) Transmitter unit. (ii) Receiver unit (iii) Relay unit.

(i) **Transmitter unit.** Fig. 30.29 gives the general arrangement of power line carrier protection scheme.

Frequencies between 50 to 500 kHz are employed in different frequency bands. Each band has certain band width (say 150—300kHz, 90—115kHz).

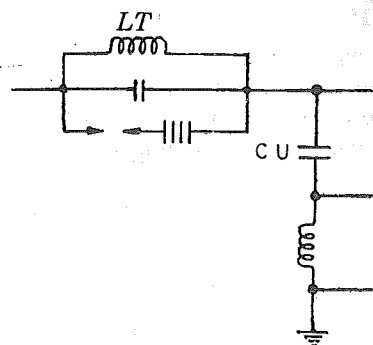

Fig. 30.28. Protective gap for line trap and coupling capacitor.

Carrier frequencies are generated in *oscillator*. The oscillator can be tuned to a particular frequency selected for the application. Or it can be a crystal oscillator with which the operation for a particular band width can be achieved by selecting on appropriate crystal. The output voltage of the oscillator is held constant by voltage stabilizers.

The output of the amplifier is fed into the *amplifier** to overcome the losses in the transmission path between the transmitter and receiver at remote end of the line. Signal attenuation comprises.

- losses in coupling equipment which are constant in the given frequency range.
- line losses which vary with length of line, frequency weather conditions, tee of connections of the line, the size and type of line. The h.f. losses of underground line are higher than overhead line.

The losses in overhead line are affected by weather. In fair weather the attenuation is about 0.1 dB/kHz at 80 kHz rising 0.2 dB/km at 380 kHz. The output of amplifier is of the order of 20 W for a 250 km line. The amplifier should be designed for maximum power over a selected bandwidth.

The *control* of transmitter can be achieved by different methods depending upon the type of protection desired.

Amplifier constantly energized transmission initiated by energizing the oscillator. In this method the oscillator stability and response time is a constraint.

Amplifier and oscillator constantly energized and the signals are initiated by interconnecting the oscillator to the amplifier. The control circuit switches the device which interconnects the oscillator to the amplifier.

(ii) **Receiving unit.** The high frequency signals arriving from remote end are received by Receiver. The receivers, the signal sand feeds to carrier receiving relay unit (Fig. 30.29). Receiving unit comprise.

- An attenuator, which reduces the signals to a safer value.
- Band pass filter, which restricts the acceptance of unwanted signals (signals from adjacent sections, spurious signals.)
- Matching transformer or matching element to match the impedances of line and receiving unit.

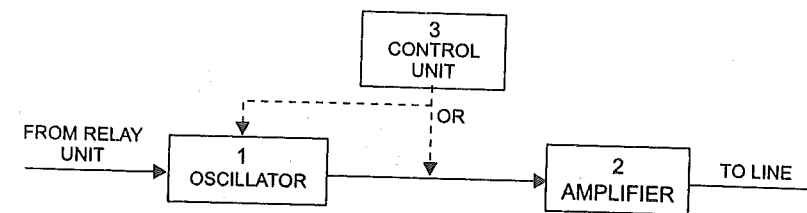

1. Oscillator generates high frequency signals.
2. Amplifier amplifies the signals.
3. Control unit controls the initiation action.

Fig. 30.29. (b) block diagram of transmitting unit.

* Amplifier increase the signals to be transmitted. Attenuator weakens the signals received.

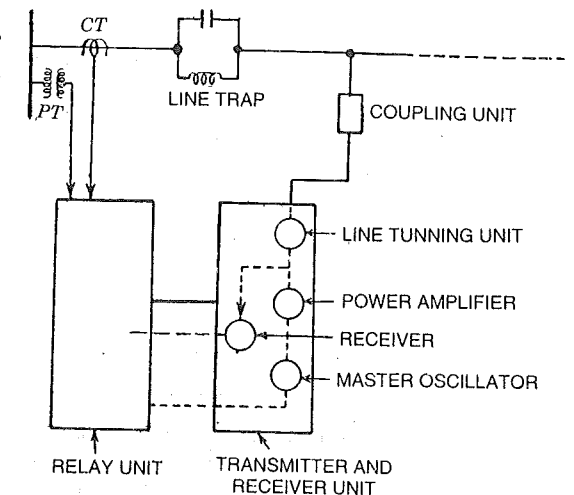

Fig. 30.29. (a) Schematic Diagram of Carrier Current Units.

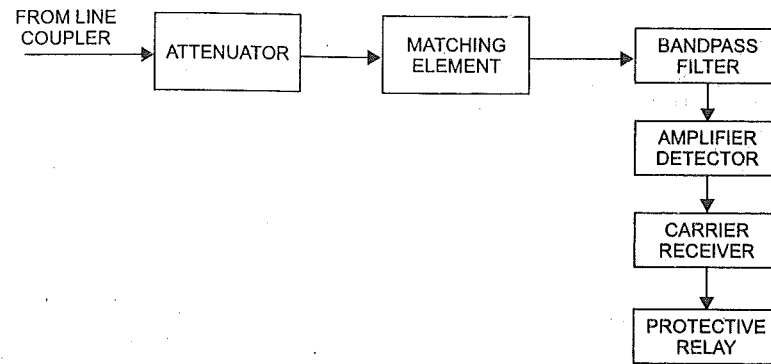

Fig. 30.30. Block diagram of receiving unit.

The spurious signals are caused by short-circuits, radio interference. To avoid the mal-operation due to noise, a setting above 2 milliwatts recommended is given to the receiver. This setting is above the noise level. To avoid operation due to spurious signals, the carrier signals should have higher power level (20 W) and receiver should be set at a higher level (5 milliwatts). Before feeding the signals to amplifier detector, the signals should be attenuated to avoid overloading.

(ii) **Frequency spacing.** Different frequencies are used in adjacent line sections. The wave-traps ensure that the carrier signals do not enter the next line section. The receiver filters filter-out other frequencies.

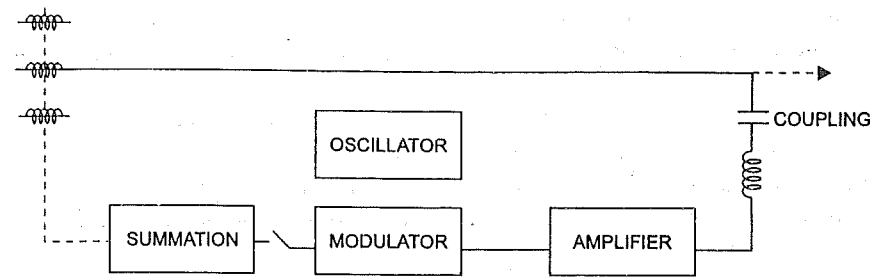

Fig. 30.31. Block diagram of modulator.

The choice of frequency bands for various sections should be co-ordinated.

(iv) **Modulation of high frequency signal.** The modulator modulates 50 Hz signals and the modulated signal is fed so the amplifier and is then transmitted via coupling unit (Fig. 30.31).

The process involves taking half cycle of current and producing the requisite blocks of carrier (Fig. 30.32) by turning the oscillator on. The level of line current at which the oscillator is made on to produce the carrier blocks should be theoretically constant. However, in practice there is a critical minimum current.

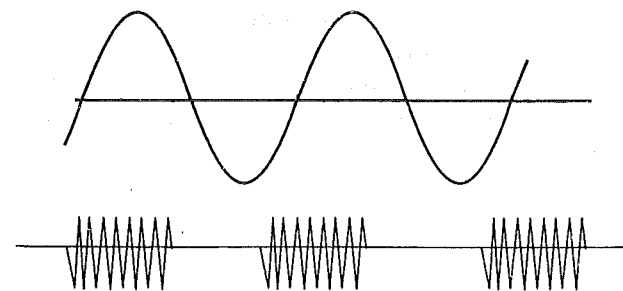

Fig. 30.32. Modulation of line current into high frequency blocks.

30.20. PHASE COMPARISON CARRIER CURRENT PROTECTION

There are different methods of carrier current protection such as :

(1) **Directional comparison method***

* Refer Sec. 30.14 for distance-carrier schemes, Carrier Transfer/Blocking etc.

(2) **Phase comparison method.**

Phase comparison method compares the phase relation between current entering in the protected zone and current leaving the protected zone. The magnitudes of currents are not compared. Phase comparison provides only main protection. Back up protection should be provided in addition. In one of the phase comparison methods signals are sent from each end of the line and received at the other end. The signals are related to the current flow in the main line, as they are derived from CT secondary current. When there is no fault, the signal is sent for alternate 1/2 cycles from each end which result in continuous signal over the line half the cycle from one end, remaining half from the other. The same condition holds good from an external fault. During internal fault the current in one of the lines reverses in phase or differs in phase and remains below the fault detector setting, so that carrier is sent only for half the time. The relay is arranged to sense the absence of signal in the line. Depending upon the setting, the tripping occurs when the phase angle between the two signals reaches a certain value.

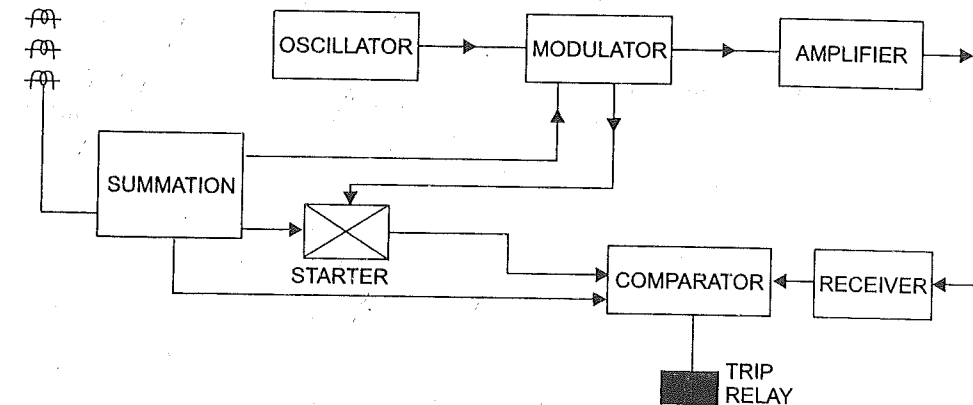

Fig. 30.33. Block diagram of phase comparison circuit.

Referring to Fig. 30.34, for internal fault condition shown on right hand side, the transmitted signals and received signals are almost in phase. The comparator compares these signals. Due to absence of signals for alternate half cycles, the comparator gives output causing operation of trip relay.

Carrier signals are transmitted to the line from both ends. For external faults the effect produced by the sum of these two signals is similar to that obtained when a continuous high frequency carrier is available on the line, and the protection is designed to remain stable under the condition. The sum of these two signals on all internal faults produces an effect similar to the periodic suppression of such a continuous carrier, the duration of each suppression being proportional to the phase-displacement between the primary current at both ends. The protection is designed to operate for phase-displacements greater than a normal angle 30° . Thus for phase-displacements of less than 30° the protection will stabilise. This angle is usually referred to as the stabilising angle of the protection (angle X in Fig. 30.34 (b)).

Fig. 30.34 (a) illustrates the two extreme cases with symmetrical fault conditions. The external-fault condition is implied by the fact that the primary current at both ends is in phase and the internal fault condition by the fact that the two primary currents are 180° out of phase.

As a first step to produce the required carrier-signals the secondary current at one end only (end B) is made 180° out of phase with the primary current by the reversal of the current-transformer connections. Thus for external faults the secondary currents at the two ends are 180° out of phase with each other. (Fig 30.34 (b)).

It will be seen that the carrier-signal produced at both ends takes the form of a continuous carrier which is periodically suppressed. In other words, a high frequency signal is only transmitted on alternative half-cycles of the power-frequency corresponding say to the period when the sec-

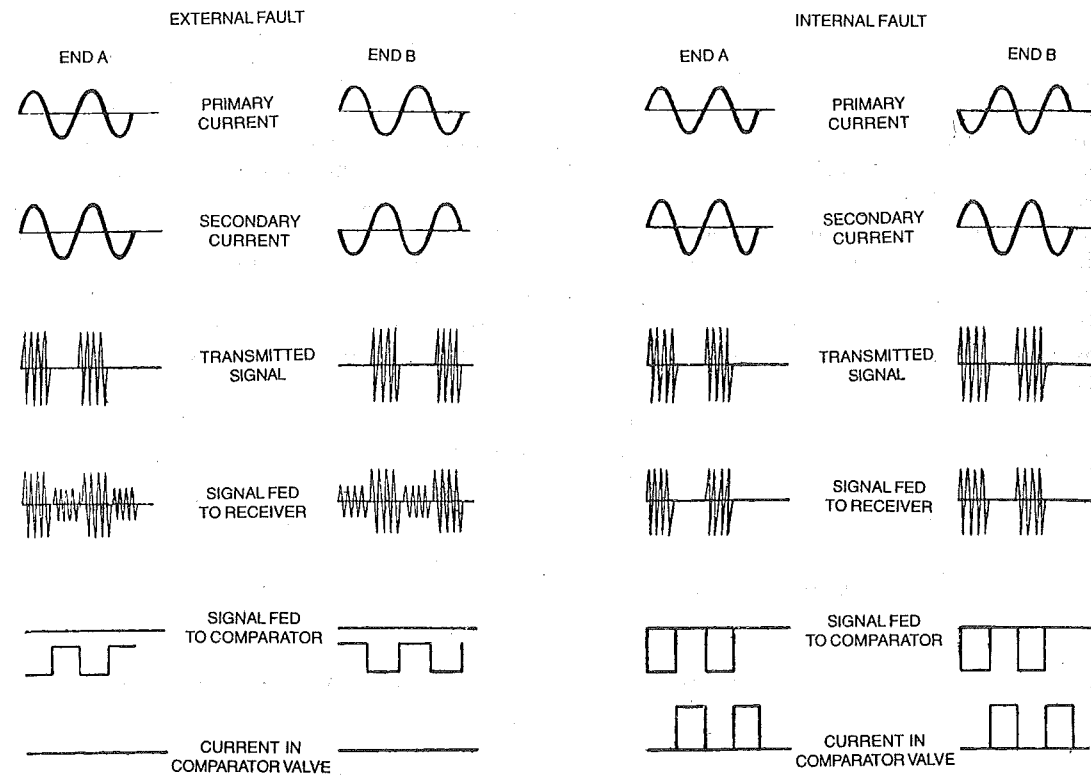

Fig. 30.34 (a). Diagram illustrating the working principle phase comparison method.

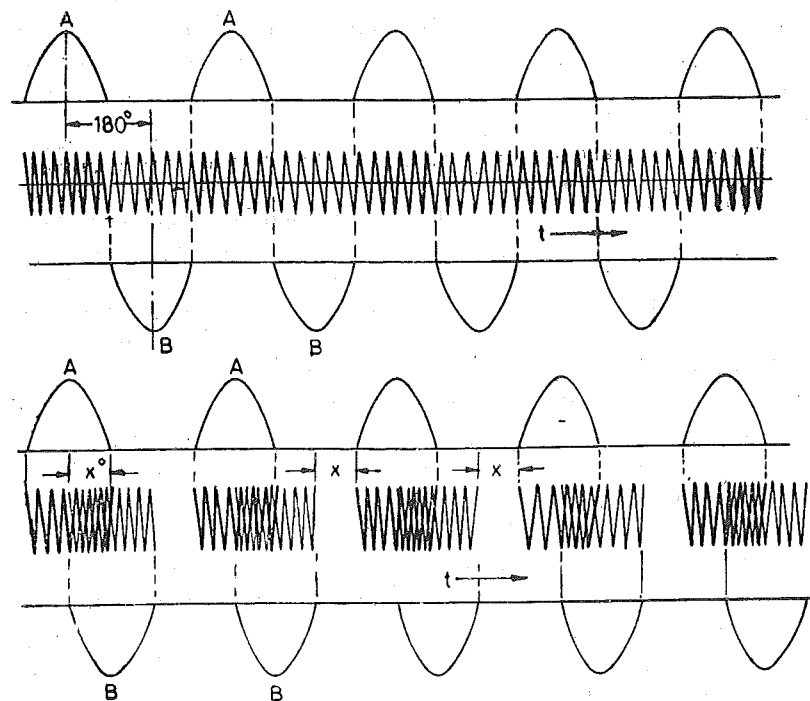

Fig. 30.34 (b)

dary current is positive. The type of high frequency signals is achieved by a process of modulation, whereby the normally consistent magnitude of a high frequency carrier is made to vary in accordance with a square wave-shaped derived from the power current and having the same period (Ref. Fig. 30.32).

30.21. APPLICATIONS OF CARRIER CURRENT RELAYING

Pilot channel such as carrier current over the power line provides simultaneous tripping of circuit-breakers at both the ends of the line in one to three cycles. Thereby high speed fault clearing is obtained, which improves the stability of the power system. Besides there are several other merits of carrier current relaying. These are :

1. Fast, simultaneous operating of circuit-breakers at both ends.
2. Auto-reclosing simultaneous reclosing signal is sent thereby simultaneous (1 to 3 cycles) reclosing of circuit-breaker is obtained.
3. Fast clearing prevents shocks to systems.
4. Tripping due to synchronizing power surges does not occur, yet during internal fault clearing is obtained.
5. For simultaneous faults, carries current protection provides easy discrimination.
6. Fast (2 cycle) and auto-reclosing circuit-breakers such as air blast circuit-breakers require faster relaying. Hence, the carrier current relaying is best suited for fast relaying in conjunction with modern fast circuit-breakers (Ref. Table 44.1)
7. **Other uses of carrier equipment.** The carrier current equipment is used for several other applications besides protection. These are :

(a) **Station to station communication.** In power station, receiving stations and sub-stations telephones are provided. These are connected to carrier current equipment and conversion can be carried out by means of "Current Carrier Communication".

(b) **Control.** Remote control of power station equipment by carrier signals. (Ref. Sec. 46.1)

(c) **Telemetry** (Ref. Sec. 46.5)

30.22. RADIO LINKS OR MICROWAVE LINKS

Radio links are used for all forms of protections otherwise based on power line carrier or pilot wire. The transmission is generally by line of sight and this must take into account the curvature of the earth and topology of the route cover which the transmissions takes place. The suitable range is about 60 km.

Frequency bands used are of the range 80—170 MHz, 470 MHz, 1500 to 7500 MHz. The transmitters and receivers are controlled in the same manner as the carrier current transmitter and receiver. With radio links (microwave pilots) the signals are sent by line of light antenna equipment. Thus the coupling and trapping units are eliminated. In U.S.A., radio links are used for communications, remote control and protection.

These are most expensive, but give fast and reliable service.

Summary

Lines or feeders can be protected by several methods. Each method has some advantages and some limitations. The classes of protective relays used for line protection; roughly in ascending order of cost and complexity are :

- Instantaneous overcurrent
- Directional overcurrent
- Pilot (pilot wire, power line carrier, or microwave).
- Time-overcurrent
- Distance

Graded time lag and grade current overcurrent protection is used for single radial feeders where time lag can be permitted.

Distance relaying is based on measurement of impedance between relay location and fault point. It has three types namely impedance type, reactance type, mho type. The relay operates if the impedance is below the set value. Distance relay is used where time lag cannot be permitted. Differential protection is of unit type. It gives fast relaying. Pilot wire differential relaying used for lines upto 40 km of length.

QUESTIONS

- Describe with the help of neat sketches the graded time lag protection of a radial feeder. What are the disadvantages of such a protection in case of the following?
 - Parallel feeders
 - Interconnected lines
 - Fast relaying.
- Explain the principle of distance relaying applied to protection of radial transmission line. Distinguish between reactance, impedance and mho relays as regards their applications to distance protection.
- In what way is distance relaying superior to overcurrent relaying in case of feeder protection.
- Distinguish between unit protection and non-unit protection. What are the various methods of protecting a transmission line by unit protection and by non-unit protection?
- Explain with the help of neat sketches the set-up of carrier current relaying employed in transmission line protection.
- Explain the principle of
 - Line trap unit
 - Coupling unit.
- Explain the phase comparison method of carrier current protection.
- Explain the directional comparison method of carrier current protection. Why should it be used in impedance or other type of non-unit protection?
- What are the merits of carrier current relaying? Where is it used? Compare pilot wire relaying with carrier current protection.
- Explain why carrier current protection is suitable for important interconnected lines.
- Explain the schemes of pilot wire relaying employed
 - Circulating current method
 - Voltage balance method.
 What are the difficulties in circulating current protection of feeder.
- State the applications of power line carrier signals.
- Select suitable relaying method under the following conditions. Give reasons for your selection.

Case (a) Protection of radial feeder from a power station to receiving station. Length of the feeder about 500 km. There are two stations in between. Time lag cannot be permitted.

(b) An interconnecting line between two power station 16 km apart.

(c) A feeder in case (a), but for following conditions.
The line is fed from both the ends and fast relaying is desired for internal faults.

(d) Distance protection of a feeder of

 - Medium length
 - Short length
 - Very long feeder
 State what type of distance protection will be suitable.
- Discuss the various methods of protection of a transmission line with reference to advantages and disadvantages of each method.
- Explain the principle of any one of the following :
 - Carrier transfer
 - Carrier blocking (Directional comparison)
 - Carrier acceleration
- Explain the 3-steep characteristic of distance relay.
- Explain the difference between 'switch' and 'non-switch' distance schemes.
- Explain the functions of starting element, measuring element and time in distance protection.
- Explain how power-swing affects distance relays.

Protection of Induction Motors

Introduction — Abnormal conditions — Under voltage protection — Contactors — Circuit Breaker — Motor protection — Single phasing protection — Short Circuit protection — Grounding — Protection of motors in general — Summary.

31.1. INTRODUCTION

The type of protection used for a particular motor depends on the switchgear used for its control (starting, stopping, speed variation, etc.) In general two basic protections are provided for every motor which are :

1. Thermal overload protection
2. Short circuit protection.

The switchgear used for motor control falls in two distinct classes:

- (i) Contactor starters with H.R.C. Fuse and thermal over current relays.
- (ii) Circuit-breakers and associated protective relays.

Contactors and fuses are used for motors upto approximately 150 kw. For larger motors, circuit-breakers are used.

Contractors are available for a wide range of a.c and d.c. duties (Ref. Sec. 15.10).

In general contactors can be used where current to be interrupted is limited to about six times rated current. The rated current is a little higher than the full load current of the motor (Ref. sec. 15.13).

Direct acting overload trip devices such as thermal overload relay can be incorporated with the contactor starter. The protection against short circuits is provided by HRC Fuses. The fuse selection depends upon starting current. The fuse should blow at currents more than those which can be interrupted by the contactor.

In case of voltage loss the coil is de-energised and the contactor opens. The motor has to be started again. Hence the contactor starter provides no volt release. Generally start, stop, reverse buttons are provided along with the starter. Large motors are provided with various relaying schemes and a circuit-breaker. The circuit breaker is air-break type or vacuum or SF₆. Air-break type circuit-breakers are more popular. The closing mechanisms are manually operated or solenoid operated or spring closing type. Solenoid closing is suitable for remote controlled motors and larger motors. Generally overload trip devices operating direct on the tripping mechanisms form and integral part of the circuit-breaker.

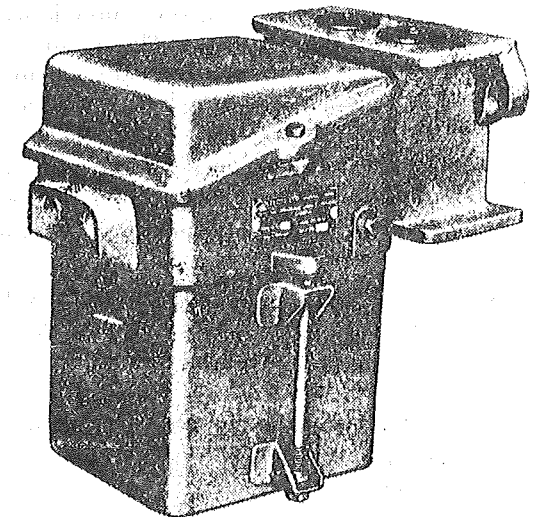

Fig. 31.1. Oil immersed direct on line starter.
(Courtesy : Jyoti Ltd., India.)

Motors rated upto 1000V are usually protected by HRC Fuses. Motors rated between 660 V and 2200 V are protected by direct acting overcurrent trip device associated with circuit-breaker. Differential protection is applied to motors rated above 3.3 kV, 1500 kW.

31.2. ABNORMAL OPERATING CONDITIONS AND CAUSES OF FAILURES IN INDUCTION MOTORS

Three phase induction motors are very widely used for industrial use. The abnormal conditions can be classified follows :

1. *Mechanical overloads*
 - sustained overloads
 - stalling
2. *Abnormal supply conditions*
 - loss of supply voltage
 - phase sequence reversal of supply voltage
 - overvoltage
 - under frequency.
3. *Faults in starting supply/circuit*
 - interruptions in phases
 - short circuit in supply cable.
4. *Internal Faults in Motor itself*
(Caused by 1, 2, 3 above)
 - phase to phase faults
 - failure to phase (open circuit)
 - prolonged starting or locked rotor
 - unbalanced supply voltage
 - undervoltage
 - blowing of fuse/single phasing
 - phase to earth faults
 - mechanical failure.

The abnormal conditions are summarised below.

- *Prolonged overloading.* It is caused by mechanical loading, short time cyclic overloading. Overloading results in temperature rise of winding and deterioration of insulation resulting in winding fault. Hence motor should be provided with overload protection.
- *Single phasing.* One of the supply lines gets disconnected due to blowing of a fuse or open circuit in one of the three supply connections. In such cases the motor continues to run on a single phase supply. If the motor is loaded to its rated full load, it will draw excessive currents on single phasing. The winding get overheated and damage is caused. The single phasing causes unbalanced load resulting in excessive heating of rotor due to negative sequence component of unbalanced current. Static single phasing relays are becoming very popular.
- *Stalling.* If the motor does not start due to excessive load, it draws heavy current. It should be immediately disconnected from supply.
- *Stator earth faults.* Faults in motor winding are mainly caused by failure of insulation due to temperature rise.
- *Phase to phase faults.* These are relatively rare due to enough insulation between phases. Earth faults are relatively more likely.
- *Inter-turn faults.* These grow into earth faults. No separate protection is generally provided against inter-turn faults.
- *Rotor faults.* These are likely to occur in wound rotor motors, due to insulation failure.
- *Failure of bearing.* This causes locking up of rotor. The motor should be disconnected. Bearing should be replaced.
- *Unbalanced supply voltage.* This causes heating up of rotor due to negative sequence currents in stator winding.
- *Supply undervoltage.* The undervoltage supply cause increase in motor current for the same load.

- *Fault in starter or associated circuit.* The choice of protection for a motor is depends upon the size of the motor, its importance in the plant, nature of load. Table 31.1 gives an idea about the motor protection practice.

31.3. PROTECTION REQUIREMENTS

Motor protection should be simple and economical. Cost of protective system should be within about 5% of motor cost. The motor protection should not operate during starting and permissible overloads. The choice of motor-protection scheme depends upon the following :

- Size of motor, rated voltage, kW.
- Type : squirrel-cage or wound rotor.
- Type of starter, switchgear and control gear.
- Cost of motor and driven equipment.
- Importance of process, whether essential service motor or not ?
- Type of load, starting currents, possible abnormal conditions, etc.

31.4. PROTECTION OF LOW VOLTAGE INDUCTION MOTOR. (BELOW 1000V AC)

31.4.1. Scheme of Starting Circuit

These are most widely used industrial motors. [Ref. Fig. 31.1 (b)].

The motor (8) is connected to three phase supply *via* the main circuit (shown dark) comprising (1) Fuse ; (2) Isolating switch ; (3) thermal relay ; (4) Contactor. The auxiliary control circuit (shown thin) (which carries only control current) comprises (5) control coil (6) ON push button usually green normally off (7) OFF push button usually red and normally closed.

Table 31.1. Protection Chart for Induction Motors

Abnormal condition	Alternate forms of protection from which choice is made	Remarks
Overloads	<ul style="list-style-type: none"> — Over load release — Thermal overload relays — Inverse overcurrent relays — Miniature circuit-breaker with built in trip coils 	<ul style="list-style-type: none"> — Overload protection given for almost all motors — Should not trip during starting currents
Phase faults and earth faults	<ul style="list-style-type: none"> — HRC fuses — High-set instantaneous over-current relays — Differential protection 	<ul style="list-style-type: none"> — Differential protection becomes economical for motors above about 1000 kW. Below this high set instantaneous protection is preferred
Undervoltage	<ul style="list-style-type: none"> — Under voltage release — Under voltage relays 	<ul style="list-style-type: none"> — Under voltage release incorporated with every starter — Under voltage relay used in certain applications
Unbalanced voltage	<ul style="list-style-type: none"> — Negative phase sequence relays 	<ul style="list-style-type: none"> — Only in special applications
Reverse phase sequence	<ul style="list-style-type: none"> — Phase reversal protection 	<ul style="list-style-type: none"> — Generally at supply point — Prevents reversal of running.
Single phasing	<ul style="list-style-type: none"> — Usual thermal overload relays — Special single phase preventer 	<ul style="list-style-type: none"> — Recently developed static single phasing devices becoming popular. — Unbalance protection
Stalling	<ul style="list-style-type: none"> — Thermal relays — Instantaneous O.C. Relays 	<ul style="list-style-type: none"> — Instantaneous trip
Rotor faults	<ul style="list-style-type: none"> — Instantaneous overcurrent relays 	<ul style="list-style-type: none"> — Only for wound rotor motors
Switching surges	<ul style="list-style-type: none"> — RC surge suppressor 	<ul style="list-style-type: none"> — 100 ohm, 0.1 μF connected between phase and ground

The operation is as follows :

When push button (6) is pressed by the operator control coil (5) gets voltage from supply.

The coil current flows through contact of (6) and (7). The energized coil lifts contactor (4) and closes Main contact (RYB) and auxiliary contacts (C). The ON push button (6) is then shunted by auxiliary contact (C). Motor starts.

If motor is to be stopped, OFF button (7) is pressed. The control coil is de-energized. The contactor opens by spring action and gravity. Motor stops.

If supply voltage fails, control coil is de-energized and contactor opens.

During overloads, the thermal relay (3) operates and thereby control circuit is internally disconnected. HRC fuses (1) provide very rapid short-circuit protection*. Current is cut-off by HRC fuse even before it reaches prospective peak. (Ref. Ch. 14).

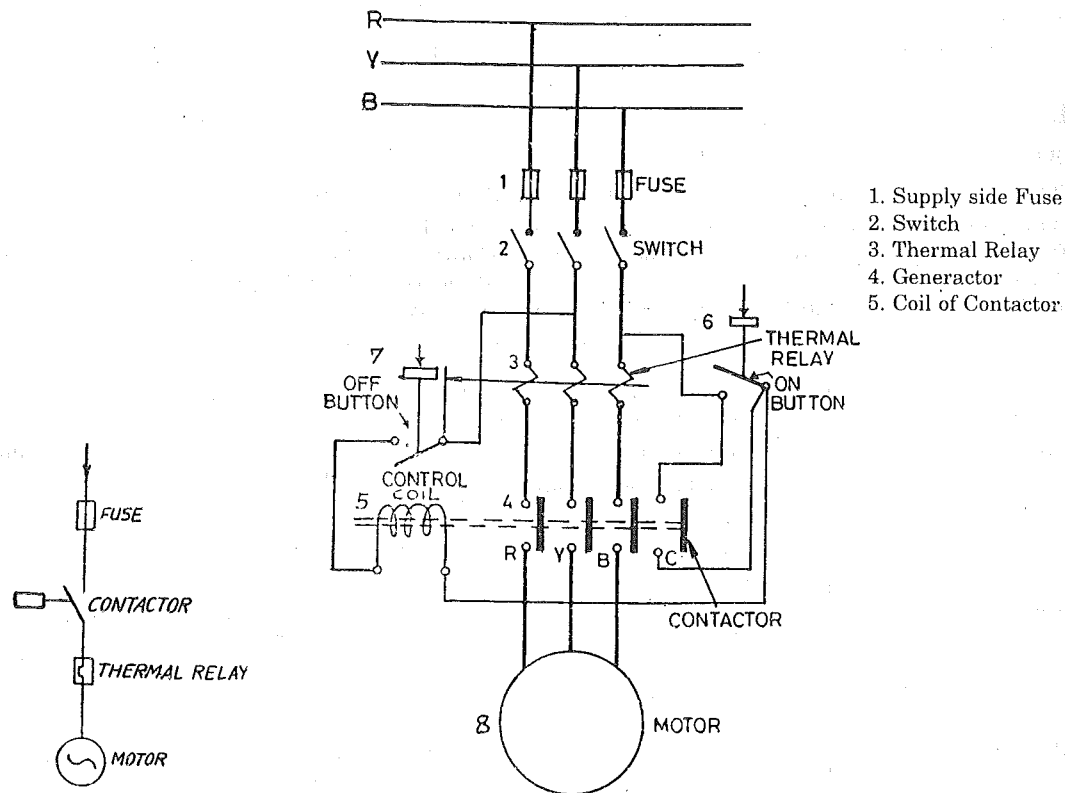

Fig. 31.1 (a). The fuse provided S.C. protection*, thermal relay provides overload protection.

Fig. 31.1 (b) Circuit of magnetic contactor starter, for low voltage induction motor.

The selection of thermal relay (3) is such that for normal starting conditions, the relay does not operate. A setting range is provided for adjustment for different variations in load conditions. It is wrong to go on increasing the setting if the motor trips during starting. The starter should be selected properly. (Ref. Tables 31.2 and 31.3).

31.4.2. Bimetal Overload Devices**

These are very popular. In case of 3-phase motors triple pole bimetal relays are generally employed. Bending of one or more bimetal strips causes movement of a common lever which in

* Ref. Ch. 14 for applications of HRC fuses for motor protection.

** Courtesy : "Over-load Protection of Motors" Mr. V.S. Bhatia, Siemens India Ltd.

turn operates the trip contact in case of overloads. The bimetal strips are either heated directly by current flowing through them or by special heater coil through which motor current flows. In case of bigger motors, they are connected in the secondary circuit of CT's. Bimetal relays can usually be set in a certain range. Most of them are provided with additional bimetal strip to enable ambient temperature compensation. Further, bimetal strips can be self-setting type or hand resetting type. In the latter, the trip mechanism locks itself in operated condition until reset mechanically.

While selecting the bimetal-overload devices for motor protection, the following aspects should be considered.

- Characteristic of relay, characteristic of motor
- Nature of loading
- Type of starting, starting current
- Protection against overloads
- Protection against single phasing.

31.4.3. Short Circuit Protection by HRC Fuses (Ref. Ch. 14)

Short circuit protection of motor, connecting feeder and starter requires careful study. The overload protective device (OLPD) and short circuit protective devices (SCPD) employed for motor protection shall be well coordinated. The range of current between 1.5 to 10 times rated current is generally termed as overload range. The motor switching device for AC-3 duty can successfully make and break over-load currents in this range. Fault currents exceeding 10 times the rated current can be considered as short circuit currents and these should be covered by short circuit protecting devices (SCPD). The SCPD may be in one of the following forms :

- HRC Fuse
- Short circuit release opening the circuit-breaker
- Instantaneous high set overcurrent relay which trips the circuit-breaker.

By proper selection of short circuit protective devices, it is possible to prevent undue damage to the motor, starter in the event of a short circuit. The back-up protection of circuit-breakers through HRC fuses is now an accepted practice. It enables the use of economical circuit breakers of low breaking capacity.

Table 31.2. Relay Selection Chart
Direct-on-line Motor Starters

3 ph 50 c/s 400/440 V motors		Full load line current in Amp.	Relay range Amp.	Back-up fuse rating in Amp. HRC fuses	
HP	kW			Max.	min.
10	7.5	13.6	13—20	50	25
12.5	9.4	17	13—20	50	25
15	11	20	20—30	80	35
20	15	28	20—30	80	60
25	18	35	30—45	100	60
30	22	40	30—45	100	60
35	26	47	45—63	125	80
40	30	55	45—63	125	80

Table 31.3. Relay Selection Chart
Automatic Star Delta Starters

3 ph 50 c/s 400/440 V motors		Full load line current Amp. I_n	$\frac{I_n}{\sqrt{3}}$	Relay range Amp.	Back-up fuse rating Amp. HRC fuses	
H.P.	kW				Max.	Min.
20	15	28	16	13—20	60	60
25	18	35	21	20—30	100	60
30	22	40	24	20—30	100	60
35	26	47	28	20—30	100	80
40	30	55	33	30—35	125	80
50	37.5	66	40	30—45	125	100
60	44	80	48	45—63	160	100
75	55	95	57	45—63	160	125

(Courtesy : Larson & Toubro Ltd., Bombay)

31.5. PROTECTION OF LARGE MOTORS (Ref. Sec. 43.7)

Large motors need protection against various abnormal conditions.

Several types of protective relays are developed to suit various applications. These relays sense the abnormal condition and trip the trip circuit of motor circuit breaker. The protection provided for large 3-phase motors takes into accounts overloads, short circuits and in some specially developed relays for motor protection, protection against unbalanced load is also incorporated. Large motors are provided with protection against following :

- Faults in windings and associated circuits
- Reduction of loss of supply voltage
- Phase unbalance, and single phasing
- Switching overvoltages
- Excessive overloads
- Phase reversal.
- Surges (Ref. Sec. 18.12)

Types of relay available for motor protection.

- Thermal protection only
- Thermal protection, Instantaneous overcurrent protection
- Thermal Instantaneous Three Phase Overcurrent, Instantaneous Unbalance, Single phasing.
- Thermal, Instantaneous three phase overcurrent, Instantaneous Unbalance, Single phasing and Instantaneous Earth fault.

The characteristic of the relays are such that the time reduces with increase in current.

Protection against short circuits is provided by high set instantaneous overcurrent and earth fault relays. Attraction armature type relays are used in some cases. The typical settings of these relays are :

- (a) 4 to 8 or 8 to 16 times full load current for instantaneous overcurrent element.
- (b) 0.2 to 0.4 times full load current for instantaneous earth fault current.

31.6. OVERLOAD PROTECTION OF INDUCTION MOTORS

The overload protective devices can be grouped as :

- Those which respond to motor current, e.g. bimetal relays, Eutectic alloy relays, electromagnetic relays, static relays. These relays opened the control circuit of the main contactor or close the trip of circuit-breaker.

- Those which respond to winding temperature, e.g., resistor devices embedded in slots, thermostats, thermistors etc. Such devices are embedded in slots and serve to supervise the winding temperature and trip the switching device.

The current sensing overload protecting devices can sense the following abnormal conditions :

1. Overloads, undervoltage
2. Single phasing
3. Locked rotor, stalling
4. Heavy starting
5. Continuous overloads
6. Heavy breaking.

However, the following conditions can be sensed only by embedded thermal devices :

1. Temperature rise due to higher ambient temperature.
2. Temperature rise due to failure of cooling.
3. Temperature rise due to other causes.

The details about Thermal Overload protection are described below.

The purpose of thermal-overload protection is to protect the motor insulation from excessive thermal stresses. During full load, the temperature of motor winding reaches almost maximum permissible unit (dependent on insulation class). During abnormal condition, the temperature exceeds the safe limit and the life of insulation is reduced.

The temperature of stator winding rises exponentially with time under moderate overloads.

The rate of temperature rise is determined by losses and thermal time constant of the stator. The heat loss from motor to surrounding air depends upon ambient temperature, ventilation and design aspects.

The time taken to reach limit of temperature rise and the shape of current *versus* time curve depends on load on the machine. For any machine, the thermal withstand curves can be drawn for 'cold' condition and 'warm' condition. The 'replica' type thermal relay operates with a thermal facsimile of the motor, i.e. the characteristic of such relay is an approximate replica of motor heating curve.

The relay is compensated for ambient temperature variation so that it can protect the motor for both cold start and hot start conditions.

The characteristic of replica relay and motor heating curve is plotted on the same current versus time curve. The relay trips at point where the motor heating curve crosses the relay characteristic. (Ref. 31.3.)

In practice, motor heating curves are not readily available. The thermal time constant or the motor can vary widely (15 minutes to 1 hour). Hence the relay characteristic should be selected and set to suit the protection requirement of particular motor.

The operating conditions resulting in temperature rise should also be considered. If motor is required for frequent starting, its temperature rise more rapid.

Referring to Fig. 31.3 curve A indicates characteristic of motor heating to reach maximum permissible temperature in 15 minutes for moderate overload (1.3 times full load current). The relay will trip according to characteristic B. e.g. for overload of 200%, the relay will trip in less than 4 seconds. Motor can withstand 200% overload for 4 minutes.

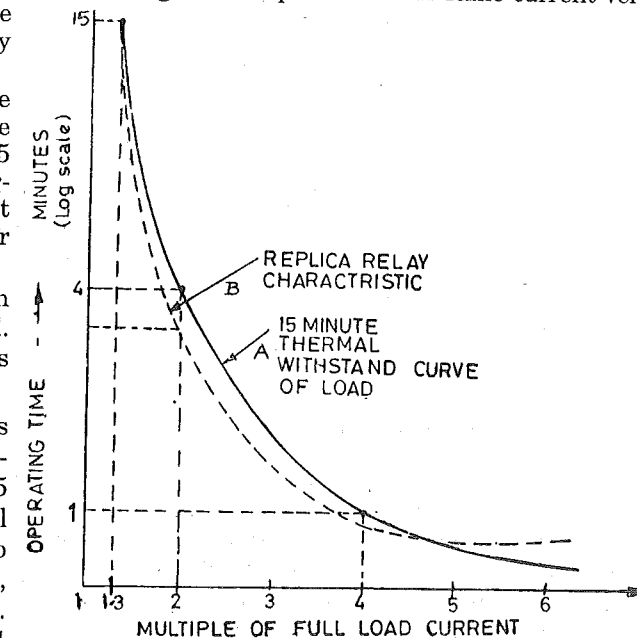

Fig. 31.3. Explaining Characteristic of Induction Motor Heating and Replica Relay.

31.7. PROTECTION AGAINST UNBALANCE

The voltage supplied to three phase induction motor can be unbalanced due to any of the following reasons :

- single phase loads on distribution service line
- blown out fuse in power factor correcting plant
- short circuit within or outside the motor
- phase failure by blown fuse. (single phasing)

The unbalanced voltage itself may not be harmful but the negative sequence currents caused by unbalanced voltage results in rotating magnetic field revolving in opposite direction. This field induces double frequency induced currents in the rotor body and conductors giving rise to heat due to copper losses (Ref. Table 31.4)

The rotor gets heated and the temperature of motor winding may reach above safe limit.

The unbalanced protection provided to a motor should prevent prolonged unbalanced condition, but should not disconnect the motor for permissible unbalance of short duration. The permissible loading depends upon the percentage unbalance and the ratio of positive sequence impedance to negative sequence impedance. (Ref. Table 31.5)

The unbalance protection is not provided, the motor should be derated to 40 to 60% of its rated full load capacity.

The unbalance voltage protection can be based upon the following methods :

1. Bimetallic relays arranged to trip faster for unbalanced currents.
2. Single phase relays sensing overcurrent in heavily loaded phases.
3. Phase unbalance relays.

Table 31.4. Derating factors of Induction Motor Under Unbalanced Supply Voltage Condition

Voltage unbalance $V_2/V_1 \times 100$	Derating factor for full load current		
	$\frac{Z_1}{Z_2} = 4$	$\frac{Z_1}{Z_2} = 6$	$\frac{Z_1}{Z_2} = 8$
1	—	—	—
5	0.96	0.93	0.9
8	0.92	0.88	0.72
10	0.9	0.8	0.56
12	0.9	0.7	0.3
15	0.9	0.4	0

Note. 1. This factor is to be applied if unbalance protection is not given.

2. Z_1/Z_2 is approximately equal to the ratio of starting current to full load current.

Table 31.5. Relation between Voltage Unbalanced and Copper Losses in Motor

% Voltage unbalance	1	2	3	5
% Stator loss *	101	102	106	115
% Rotor loss *	105	112	130	175

*For full load as per cent of losses during balanced voltage condition.

For smaller motors the cost of separate phase unbalance relay, is not justified. The unbalance protection is given by (1) and (2) on page 700. Additional phase failure relay (single phasing preventer) is provided where essential. For larger motors, additional unbalanced current relays are provided. The secondary currents of CT's are fed to negative phase sequence filter. The output of the negative sequence filter is given to a overcurrent unit or static level detector. The setting is based on the Z_1/Z_2 ratio and permissible time for per cent unbalances (Also Ref. 33-11 for Negative Sequence Circuit).

31.8. PROTECTION AGAINST SINGLE-PHASING (PHASE FAILURE)

A 3-phase induction motor continuous to run even if one of the supply lines is disconnected. The whole power is then supplied through the two windings and they are likely to get overheated. The single phasing causes unbalanced stator currents. The negative sequence component of unbalanced current causes heating of rotor and temperature rise. For small motors, separate protection against single phasing is generally not necessary as the thermal relays sense the increased current in healthy phases due to single phasing and thereby offer adequate protection.

In case of large motors (say 50 kW and above) even a modest unbalance can cause damage of motor winding due to overheating. Further, if motor is stalled due to losses of one phase, severe damage to rotor is possible while starting. Therefore, a separate single phasing protection is desirable.

Single phasing is extreme unbalance condition for a three phase motor. Such a condition can be caused by blowing of fuse in the supply circuit or due to improper contact in a switch or a contactor.

During single phasing, the current in healthy phases increases by $\sqrt{3}$ times. This increases the heating in motor windings. The unbalanced stator currents have a negative sequence component. This component causes magnetic flux rotating in opposite direction to the main flux. Thereby double frequency currents are induced in rotor body and rotor conductors. Rotor heating caused by these currents is very high. This heating is not detected by replica type thermal relays protecting the stator winding. Hence single phasing causes major damage to motor rotor. The phase overcurrent relays act slowly. Hence it cannot give instantaneous protection against single phasing.

In some applications like elevator motors, where it is dangerous to eliminate plugging, inching and reversing, the motor should be disconnected instantaneously when single phasing occurs. The phase unbalance relays (Ref. Sec. 31.10) are provided for large motors. But they are with time lag depending upon magnitude of unbalance.

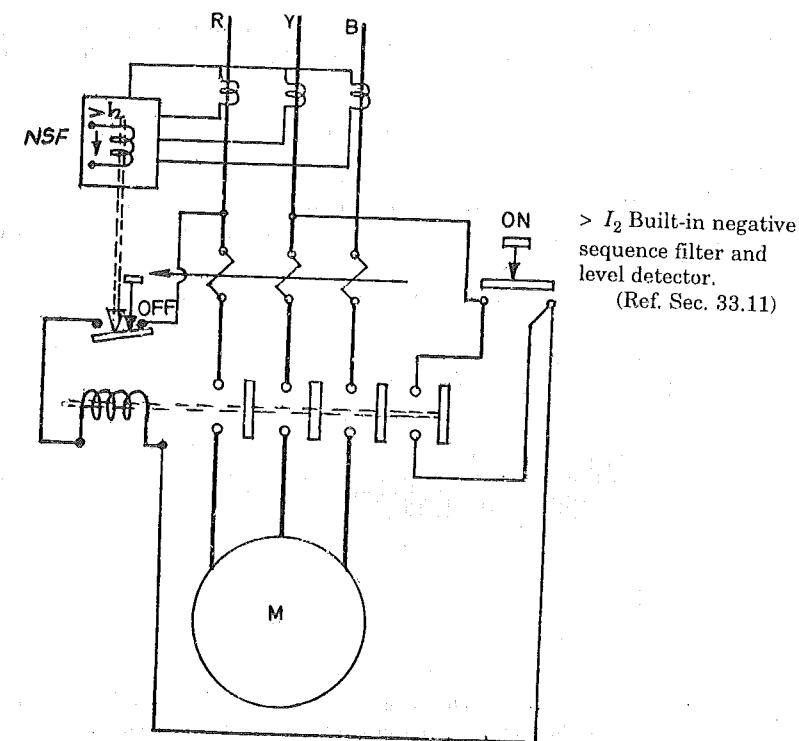

Fig. 31.4. Connections of single phasing preventer.

Single phasing preventers are used for small motors. These are connected to secondaries of line CT's. These contain a negative sequence filter. The output of the negative sequence filter is fed to a level detector (Ref. Fig. 31.4) which sends tripping command to the starter or circuit breaker when the negative sequence current exceeds a pre-set limit.

31.9. PHASE REVERSAL RELAY

The direction of rotation of an induction motor depends upon the phase sequence of the supply voltage. Phase reversal occurs when the supply connections are changed after repairs. Assuming after the repairs (at local load point or supply sub-station) the phase sequence of supply is reversed, the motor will run in wrong direction. In some applications, phase reversal is dangerous, e.g. elevators, cranes, hoists, trams etc. In such applications phase reversal relays should be provided. The phase reversal relay may be provided at main incoming substation of industrial works.

The phase reversal relay based on electromagnetic principle comprises a disc motor driven by magnetic system actuated by secondaries of two line CT's or VT's.

For correct phase sequence (RYB) the disc exerts torque in positive direction so as to keep the auxiliary contacts closed. When phase reversal takes place, the torque reverses and the disc rotates in opposite direction to open the contacts. Thereby the magnetic coil of starter can be de-energized or circuit breaker can be tripped. The *solid-state* phase reversal relays and phase failure relay senses the phase reversal or phase failure. Under abnormal condition it sends tripping command to output stage (which is a auxiliary relay or static device).

31.10. PHASE TO PHASE FAULT PROTECTION

The phase to phase fault short-circuit in stator winding causes burn-out of coils and stampings. Hence the motor should be disconnected from supply very quickly. Fast overcurrent relays are provided for phase to phase short-circuit protection.

The relays giving short-circuit protection to the motor should not act during starting currents. The setting of instantaneous overcurrent relays for phase faults should not be below the starting characteristic of the motor.

Therefore, the short-circuit protection characteristic is set just above the maximum starting current the motor.

While switching on the motor, starting current has d.c. transient and a.c. component (Ref. Sec. 3.4). The overcurrent relay set for short-circuit protection should not operate due to d.c. component. To avoid to high setting, it is a usual practice to provide a definite time lag of 2 to 4 cycles for overcurrent protection against phase faults. Thereby, the relay does not operate for initial high

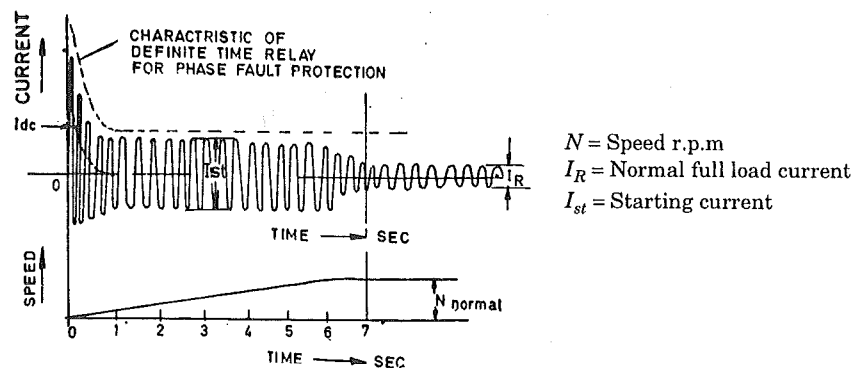

Fig. 31.5. Starting characteristic of squirrel cage induction motor co-ordinated with over-current relay for phase faults.

value of d.c. component. After three-four cycles, value of d.c. component in starting current reduces and the relay does not pick-up due to the same. (Fig. 31.5).

Limitations of Overcurrent Relays. With higher setting of overcurrent relays above starting characteristic, (say above 5 to 7 times full load current), the fault current may be less than the pick-up value of relay. This can happen for phase faults near the neutral point of the star connected motor. Although the probability of such a fault is less, the fault can cause extensive damage as it will not be cleared instantaneously.

The most sensitive and quick protection for all phase faults in the motor is possible by *Circulating Current Differential Protection* (Ref. Ch. 28). The biased differential protection prevents mal-operation due to d.c. component and CT errors.

Slip Ring Induction Motors. The starting current of slipping induction motors is limited to about 1.25 times full load current by means of resistance in rotor circuit. Hence overcurrent relays set to about 1.4 to 1.6 times rotated full load current provide satisfactory protection against phase faults.

Overload and Phase Fault Protection of Large Motors*

The characteristics of IDMT relays (inverse definite minimum time) for motor protection should be matched with the motor heating curve (Fig. 31.6). Thermal protection usually given adequate protection at light and medium long time overloads but are usually not enough for very heavy overloads. High set instantaneous overload relay do not give adequate protection against overloads. Hence the schemes of overcurrent protection of large motors include various combinations of :

- thermal overcurrent relay
- inverse long time relay
- instantaneous overcurrent relays.

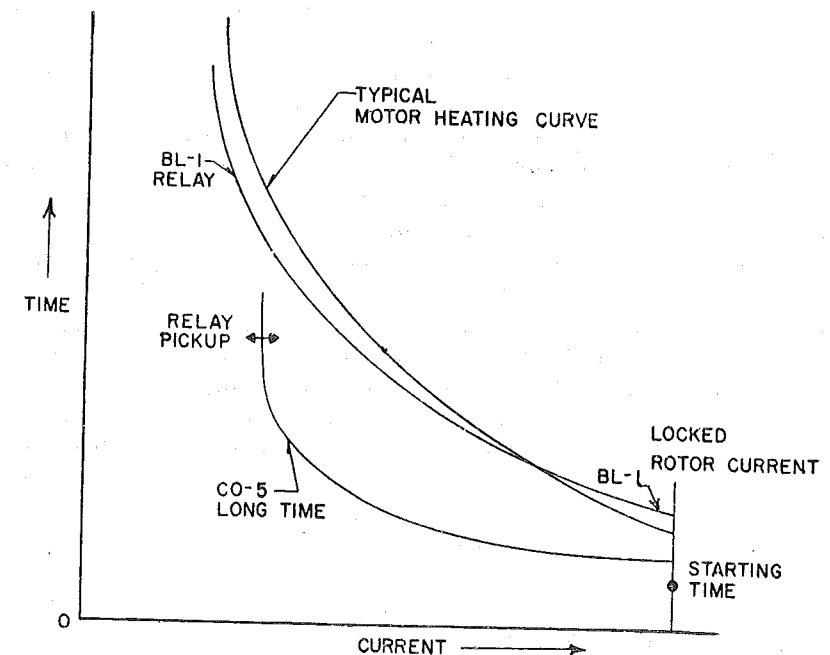

Fig. 31.6. Typical motor and relay characteristics.

Table 31.6. Overcurrent Protection for Motors*
(Earth-fault Relays Considered Separately)

Scheme	Relays applied	Action (Note 4)	Typical Settings
1.	2 thermal over-current	Trip or alarm	$100\% I_R$ (Note 1)
	1 long time ind. over-current	Trip or alarm	$300-350\% I_R$ (Note 2)
	3 instantaneous over-current	Trip	above max start I (Note 3)
2.	2 long time ind. over-current	Trip	$300-125\% I_R$ (Note 2)
	1 long time ind. over-current	Alarm	$115-125\% I_R$
	2 instantaneous over-current	Trip	above max I_{st} (Note 3)
3.	2 long time ind. over-current	Trip or alarm	$125-150\% I_R$ (Note 2)
	2 instantaneous over-current	Trip	above max I_{st} (Note 3)
4.	2 thermal over-current	Trip or alarm	$100\% I_R$ (Note 1)
	2 instantaneous over-current	Trip	above max I_{st} (Note 3)

I_R is rated (full load) motor current.

I_{st} is starting current.

Courtesy: Westinghouse Electric Corporation

*Notes. 1. Replica type relay such as BL-1. Adjustment is change in contact setting. Normal setting provides operation in 60 minutes at $125\% I_R$. Can be set at 25 minutes at 125% current.

2. Time selected so that operation occurs on locked rotor current but not on motor starting when starting time is less than locked rotor time. Where data are not available, this setting can be obtained by successive motor starts and advancing the time setting until relay operation does not occur, then add around 1-5 sec to the relay operating time. Typical setting might be 10 sec. on locked rotor current magnitude. If the relay are used for alarm only settings are reduced to 115% except where service factors or short time overload rating exist.

3. It is difficult to determine as d.c. offset currents may occur particularly when starting large motors. Setting is best obtained by successive starts to determine the no operation setting and then increasing pick-up approximately 10% . Typical settings might be 160 to 170% of locked rotor current although settings as 250% may be required. This may be 12 to 15 times rated motor current.

4. Decision to trip or alarm depends on emphasis placed on service continuity and motor protection. For essential motors of power house auxiliaries (where failure would cause shut-down of generating capacity) alarms are frequently used so that operator can take corrective measures to avoid shunt-down or transfer generation before shut-down.

5. Replica type relay attempts to duplicate on a small scale within the relay operating unit, the heating characteristic of the motor. The current from CT secondary passes through relay and its characteristic approximately parallel that of the machine as illustrated in Fig. 31.6. The BL-1 relay has two spiral-wound bimetallic springs. One is actuated by the heat produced by the applied current while the other, by the ambient temperature surrounding the relay. This provides ambient temperature compensation so that relay operates on the same time current curve approximately independent on the temperature of the air surrounding the relay.

The BL-1 relay is available with one or two thermal overload units with instantaneous trip attachments for applications.

31.11. STATOR EARTH-FAULT PROTECTION

Earth-fault protection is set to disconnect the motor from supply as early as possible so that the damage to winding and laminations is minimum.

Zero Sequence Current Transformer (ZSCT) or core balance type protection (Ref. Sec. 27.9) is very convenient method of protection of motors from earth-faults (Ref. 31.7). This method is espe-

cially suitable for system neutral earthed through resistance. In such systems, earth-fault currents are so low (due to resistance earthing) that phase overcurrent relays cannot be set to pick-up for earth faults. (Ref. Fig. 27.11 (b)—Core Balance CT)

Where the supply source is earthed, an inverse, very inverse, or instantaneous induction type relay is connected in the current transformer neutral. These sources usually have neutral impedance to limit the ground current so that sensitive ground relay settings are required. Typical settings are $1/5$ of the minimum fault current for a solid fault at the machine terminals. Time dial setting around 1 are used which give operations of $4-5$ cycles at 500% pick-up.

Occasionally the high in-rush current of direct on-line starting of large motors will cause the grounded relays to operate. This results from unequal saturation of the current transformers which causes a false residual current in the secondary or relay circuits. Two instead of three phase relays tend to increase the effect.

As a thumb-rule, no trouble should occur is the phase burdens are limited so that the voltage developed by the current transformer during starting is less than 75% of the $10 P$ accuracy rating of the current transformer. A practical solution to prevent relay operation, should trouble develop, is to increase the ground relay burden by using a lower tap. This forces all three transformers to saturate more nearly together and effectively reduce the false residual current. An alternate solution is to connect a resistor or reactor in series with the ground relay (earth faults relay).

The trend in 3.3 to 11 KV sub-stations and industrial power systems is towards higher neutral impedance and appreciably less ground fault current. This increases the problem of obtaining a very sensitive relay setting that will not operate on the false residual current of the starting inrush. This is the best solved by using a window type current transformer which has a single secondary winding surrounding all three phase conductors (Fig. 31.7). This eliminates the false residual and permits applying a very sensitive instantaneous earth-fault relay. An alternative is to use a directional overcurrent relay with the current of voltage polarizing coil connected in the ground source neutral or across the neutral resistor.

31.12. FAULTS IN ROTOR WINDING

In slip-ring induction motor, rotor faults are possible. The increase in rotor current is reflected on stator current and the stator over-current protection can thereby act. The setting of stator over-current relay is generally of the order of 1.6 times full load current. This is enough to detect the rotor faults.

Inter-turn Faults. Inter-turn faults are difficult to be, detected. The method adopted for generator stator winding inter-turn faults can be adopted for motors. But it is too complex and is not practicable.

Grounding or Earthing (Ref. Ch. 18)

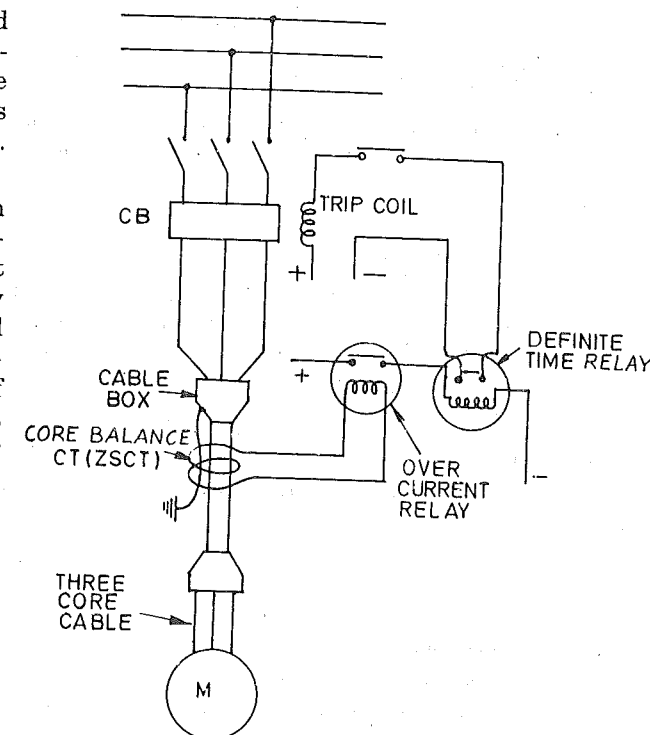

Fig. 31.7. Connections of core balance CT (Zero Sequence CT) for earth-fault protection of motor

In low voltage circuits the neutral point of supply should be earthed. In ungrounded systems a single line to ground fault on one line causes increase in voltage of healthy lines with respect of neutral by $\sqrt{3}$ times. This can damage motor insulation.

To avoid this, the neutral point of supply, should be earthed at every voltage level. Cascade failure of motors can occur if supply neutral is not earthed (Ref. Sec. 18.6.2.)

Summary (Refer Table 31.1)

The protection of motor is normally provided along with stator or switchgear.

Contactors starters or circuit-breakers are used for motor switching.

Thermal relays provided overload protection, single phasing protection. This circuit protection is provided by fuses or instantaneous relays. Protection against unbalanced supply voltage is provided by negative phase sequence relays.

H.R.C. fuses are used for short circuit protection of motor. They should be co-ordinated with overload relays.

Abnormal condition is motors include : faults, under voltage, single phasing, unbalanced voltages, overloads etc.

QUESTIONS

- Describe contactors starter of a three phase induction motor. State what protective measures are provided along with the starter ?
- Describe the principle of operation of thermal relay used for motor protection.
- State the various abnormal conditions in a 1200 h.p. Induction motor and protection provided against each.
- Distinguish between overload protection, short circuit protection and earth fault protection of motor.
- Explain how to select a fuse for motor. How to co-ordinate it with circuit breaker or contactor?
- Explain the various methods of short circuit and earth fault protection of motors.
- Which protections are provided for essential service motors?
- Discuss the causes of motor failure of both electrical and mechanical origin.
- In a factory, a 15 kW motor is to be provided with a starter. However a starter for 35 kW motor is readily available in the store. Can this starter be used ? Give technical considerations.
- It was found that the thermal relays tripped while starting the motor was started without load the thermal relay did not trip. What can be the various causes of tripping during starting?
- Explain the term "Single Phasing". In what form the protection is provided in case of
 - Fractional horse power motor
 - Large motor above 150 h.p.
- State whether correction or wrong. Write corrected statements if necessary.
 - Squirrel-cage motors can fail by rotor insulation failure.
 - In motor protection, thermal relay provide short circuit protection.
 - Phase sequence of supply determines the direction of rotation of motor.
 - Differential protection if provided for 100 h.p. motor.
 - Differential protection does not sense overloading of motors.
 - Undervoltage of supply reduce starting current of motor.

Ref. Sec. 43.7 and 43.8 for static protection scheme for motors.

1. Ref. Sec. 18.12. Protection against switching overvoltages. Vacuum circuit-breakers tend to chop the current giving switching voltage surges. RC surge suppressors are connected with such switchgear to protect motor insulation.

2. Thyristor-control of induction motors gives harmonic contents in the supply wave form. Harmonics cause addition heating in the magnetic circuit. The harmonic content in supply would be within certain limits. The voltage waveform should be sinusoidal with permissible deviation less than 3 per cent suitable harmonic filters should be provided on supply side.

Protection of Transformers

General — Protection Chart — Buchholz Relay — Sudden Pressure Relay — Biased Differential or Merz Price Protection — Problems arising in Merz Price System — Harmonic Restraint — Overcurrent Relays — Interlock protection — Restricted earth fault protection — Overfluxing protection — Protection of Arc-furnace transformers — Safety devices.

32.1. PROTECTION REQUIREMENTS

Protective equipment for transformer protection includes gas relays which give an alarm on incipient faults, differential system of protection which gives protection on phase to phase faults plus phase to ground faults, other protective relays, and surge arresters which give protection to the insulation from high voltage surges (Ref. Table 32.1)

A *Through Fault* in one which is beyond the protected zone of the transformer, but fed through the transformer. The unit protection of the transformer (usually differential current protection) should not operate for through faults. The overload relaying may be provided to operate with a time lag to provide back-up protection. Internal faults are those in the protected zone of the transformer. These faults can be between phase-to-phase and phase-to-ground. Generally they result from failure of insulation due to temperature rise or deterioration of transformer oil. Incipient faults are initially minor faults causing gradual damage. These faults grow into serious faults. Incipient fault include loose connections in conducting path, sparking, small arcing, etc.

The faults occurring in power transformers are earth-faults phase-to-phase faults, inter-turns faults and overheating from overloading or from some internal cause such as core-heating. Of these the most common are earth-faults ; inter-turns faults ; but the latter develop rapidly into earth-faults and, therefore, only earth-fault protection is generally provided.

The choice of protection for any given power-transformer depends upon a number of factors, such as its size, importance, and whether it has no-load or off-load tap changer.

The following information is necessary while selecting the protection scheme for a power transformer.

1. Particulars of transformer

- | | |
|--|--------------------------|
| (a) kVA | (b) Voltage ratio |
| (c) Connections of windings | (d) Percentage reactance |
| (e) Neutral point earthing, value of resistance | |
| (f) Value of system earthing resistance | |
| (g) Whether indoor or outdoor, dry or oil filled | |
| (h) With or without conservator. | |

2. Length and cross-section of connecting leads between CT's and relay panel.

3. Fault level at power transformer terminals.

4. Network diagram showing position of transformer, load characteristics.

The general practice of protection of power transformer is given in Table 32.1.

The faults in transformer can be caused by failure of insulating materials due to dust, moisture, voids weakening of winding due to external short-circuits.

The surge arresters provided at the bus-bars or at transformer terminals spark-over at about 80% of impulse insulation-level of the transformer and protect the transformer against surges. (Ref. Ch. 18).

Table 32.1. Power Transformer Protection

Abnormal condition	Protection	Remarks
Incipient faults below oil level resulting in decomposition of oil, faults between phases and between phase and ground.	Buchholz relay sounds alarm (Gas actuated relay). Sudden pressure relay Pressure relief valve	Buchholz relay used for transformers of rating 500 kVA and above.
Large internal faults phase-to-phase, phase to-ground, below oil level.	1. Buchholz relay trips the circuit-breaker.	Buchholz relay too slow and less sensitive. Buchholz relay for tapchanger also.
Faults in tap-changer.	2. Percentage differential protection. 3. High speed high set over-current relay.	Percentage differential protection used for transformers of and above 5 MVA.
Saturation of magnetic circuit	1. Over fluxing protection 2. Overvoltage protection	For important generator transformer and feeder transformers.
Earth faults	1. Differential protection.	For transformers of and above 5 MVA.
	2. Earth fault relay.	(a) Instantaneous Restricted E.F. Relay. (b) Time lag E.F. Relay.
Through faults	1. Graded time lag overcurrent relay 2. HRC Fuses (Ref. Ch. 14)	Protection of distribution transformers. Small distribution transformers upto 500 kVA
Overloads	1. Thermal overload relays. 2. Temperature relays sound alarm.	Generally temperature indicators are provided on the transformers. Temp. increase is indicated on control board also. Fans started at certain temp.
High voltage surges due lightning, switching (Ref. Ch. 18)	1. Horn gaps. 2. Surge arresters. 3. R-C Surge suppressors	Not favoured In addition to arresters for incoming lines.
Small distribution transformers		Only H.V. fuses for earth faults protection and phase fault protection. Overload protection generally not provided. (Fig. 14.12, 14.15).
		For more important transformers of about 500 kVA Overcurrent relays Instantaneous earth fault relays
Transformer in important locations, ratings 500 kVA above		Restricted earth-fault protection Overcurrent and E.F. protection Buchholz relay
Transformer of about 5 MVA and above		Differential protection, Restricted earth fault protection, Overcurrent protection, Overfluxing protection, Buchholz Relays, Sudden pressure relays.

Undervoltage and overvoltage relays : wherever necessary.
Reverse power relay : for parallel transformers. (Sec. 32.12).

32.2. SAFETY DEVICES WITH POWER TRANSFORMERS

The electrical portion systems can sense the abnormal conditions by measuring current/voltage. Besides electrical relays, a power transformer can be provided with the following safety and monitoring devices.

- | | |
|------------------------------------|---------------------------------|
| (a) Fluid level gauge | (b) Vacuum gauge |
| (c) Pressure/vacuum switch | (d) Sudden Pressure Relay |
| (e) Pressure Relief Valve | (f) Fluid temperature Indicator |
| (g) Hot spot temperature indicator | (h) Gas temperature indicator |

32.3. LOW OIL LEVEL—FLUID LEVEL GAUGE

Low oil level is a harmful condition because internal insulation clearance, creepages etc. between leads, bushings and tanks are exposed to air when the oil drops below the specified level. Low oil level could result from (1) initial mistake to fill sufficient oil upto the mark (2) Leakage of oil through the tank.

If the cooling tubes are partially cool or nearly at ambient temperature, it is an indication that the oil is not circulating in the cooling tubes or oil level has dropped below the desired level. The cooling tubes are warm and level indicator gives an alarm, it may be a false alarm and level indicator needs checking. Its position may be improper.

The level indicator has a float and an arm. The float is suspended in the oil. When the oil level drops down, the float tilts the arm thereby closing the alarm contacts. Both low and high level alarm contacts are provided.

32.4. GAS ACTUATED DEVICES

During internal faults below oil level, the heat of arc causes decomposition of oil. The gases formed by decomposition are gathered in the air cushion and the conservator of the transformer. The rate of gas generation depends upon fault current and arc voltage.

The arc voltage is of the order of 50 to 200 volts and the rate of gas generation is of the order of 50 to 200 cubic centimetres per kilowatt sec. The fault may be inter-turn fault, earth fault or phase to phase fault.

The gases generated by the arc can be used for detecting these faults. The following devices are used.

- pressure relief devices
- rate of rise pressure relay
- gas accumulator relay (Buchholz Relay).

32.4.1. Pressure Relief and Pressure Relay

This is different from rate of rise pressure relay.

Pressure relay and pressure relief device is mounted on transformer tank. It releases gas pressure to the atmosphere during.

- high overload peaks
- prolonged overloads
- arcing faults within oil.

The pressure relief valve is spring loaded and has a seal-seat. (Fig. 32.1 a). When the pressure inside the tank increases above a certain value, the force on movable sub-assembly exceeds the spring force and the valve operates (Fig 32.1 b). The alarm contacts are closed. After release of pressure the valve may be manually reset (not shown in figure).

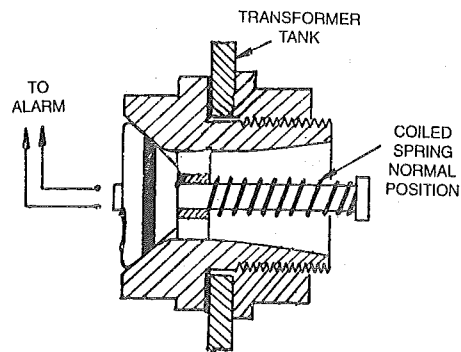

(a) Normal Position.

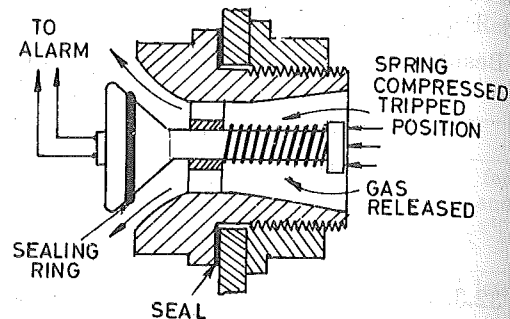

(b) During internal pressure.

Fig. 32.1. Pressure relief device and sudden pressure relay for transformer protection.

32.4.2. Rate-of-Rise Pressure Relay

Rate of rise pressure relay does not respond to static pressure. It responds only to rate of rise pressure resulting from internal arcing. The main pressure sensing element is a pressure actuated micro-switch mounted inside a metallic bellows. Static pressures do not squeeze the bellow. Dynamic pressure squeeze the bellow and operate the micro-switch. (Fig 32.2)

In some designs, oil pressure itself squeezes the bellow filled with special oil.

Rate of rise pressure relay is generally arranged to trip the transformer. It can be mounted on the tank.

32.4.3. Buchholz Relay (Gas Actuated Relay)

1. **Principle.** The incipient faults in transformer tank below oil level actuate Buchholz relay so as to give an alarm. The arc due to fault causes decomposition of transformer oil. The product of decomposition contain more than 70% of hydrogen gas, which being light, rises upwards and tries to go into the conservator. The Buchholz relay is fitted in the pipe leading to the conservator. The gas gets collected in the upper portion of the Buchholz relay, thereby the oil level in the Buchholz relay drops down. The float, floating in the oil in the Buchholz relay tilts down with the lowering oil level. While doing so the mercury switch attached to the float is closed and the mercury switch closes the alarm circuit. Thereby the operators know that there is some incipient fault in the transformer. The transformer is disconnected as early as possible and the gas sample is tested. The testing of gas gives clue regarding the type of insulation failure. Buchholz relay gives an alarm so that the transformer can be disconnected before the incipient fault grows into a serious one.

When a serious short circuit occur in the transformer, the pressure in the tank increases. The oil rushes towards the conservator. While doing so it passes through the Buchholz Relay. The baffles (plates) in the Buchholz relay get pressed by the rushing oil. Thereby they close another switch with in turn closes the trip circuit of circuit-breaker. Thereafter the transformer is removed from the service.

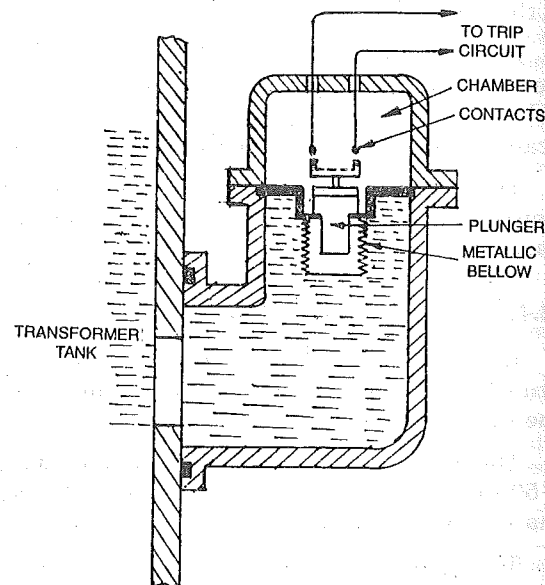

Fig. 32.2. Rate of rise pressure relay.

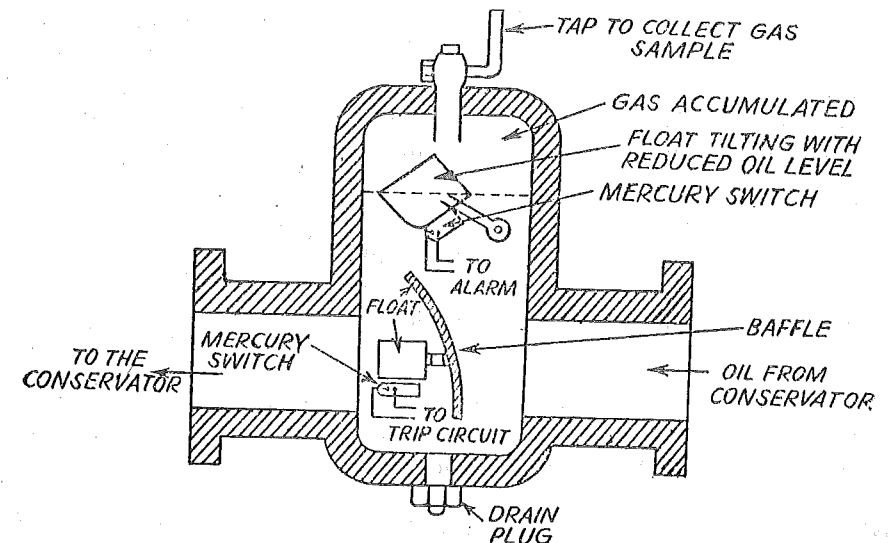

Fig. 32.3. Buchholz relay principle. (Gas Operated Relay)

The decomposition of transformer oil starts at about 350°C. The gas accumulated in the upper portion of the relay can be tapped. The gas is tested for colour, combustibility, chemical test etc. IS 3638-1966 'Application Guide for Gas operated Relay' gives details about analysis and mounting. From its analysis the kind of failure can be predicted. The insulation can be repaired before a major breakdown occurs.

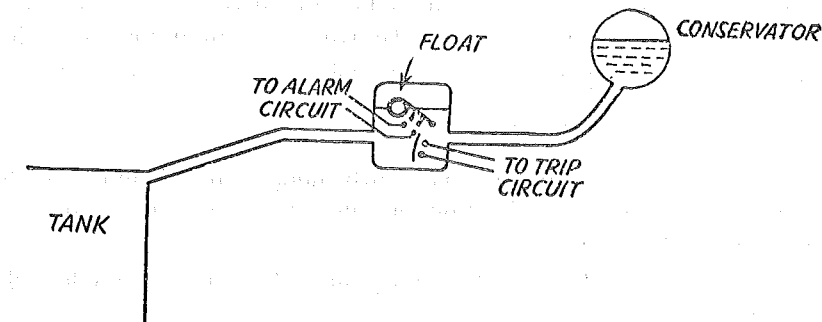

Fig. 32.4. Arrangement of Buchholz relay.

This type of relay can be used only for transformers with conservator. For faults above the oil level, this relay is ignorant. Buchholz relay gives an alarm when the oil level reduces below a certain level due to leakage of oil transformer.

A Buchholz relay is installed in the pipe connecting the transformer tank and the oil conservator (Figs. 32.3, 32.4, 32.5). The following are the guide lines for the installation.

- The angle of inclination of the axis of the pipe with horizontal plane should be between 10 to 11°
- The length of the straight run of the section of the pipe between the relay and the transformer tank should be more than $5D$ (D is the internal diameter of the connecting pipe)
- The length of the straight run of pipe after the Buchholz relay upto the conservator should be more than $3D$.

*The nominal pipe bore diameter is recommended by Standards as 25 mm for transformers upto 1000 kVA, 50 mm for between 1000 to 10,000 kVA and 80 mm for above 10,000 kVA.

Limitations of Buchholz Relay

Only faults below oil levels are detected.

Setting the mercury switch cannot be too sensitive otherwise there can be a false operation by vibrations, earthquakes, mechanical shocks to the pipe, sitting of birds etc.

The relay is slow, minimum operating time is 0.1 second, average time 0.2 second. Such a slow relay is unsatisfactory.

However, it is an excellent relay to bring to notice incipient fault.

Buchholz relays are not provided for transformers below 500 kVA. (This is for economic considerations). A separate Buchholz relay is provided with the tap changer to detect the incipient faults in the tap-changer. This does not respond to a small arcing.

32.5. BIASED DIFFERENTIAL PROTECTION, PERCENTAGE DIFFERENTIAL PROTECTION OF POWER TRANSFORMER (Ref. Ch. 28)

(a) **Description.** The differential protection responds to the vector difference between two similar quantities. In protection of transformer, CT's are connected at each end of the transformer. The CT secondaries are connected in star or delta and pilot wires are connected between the CT's of each end. The CT connections and CT ratios are such that currents fed into the pilot wires from both the ends are equal during normal conditions and for through faults. During the internal faults such as phase to phase or phase to ground, the balance is disturbed. The out of balance current $I_1 - I_2$ flows through the relay operating coils. To avoid unwanted operation on through faults resistor-train bias coil are provided in series with pilot wires. The ampere turns provided by bias coils or restraining coil are proportional to $\frac{I_2 + I_1}{2}$.

As a result the restraining torque increases with through current and relay does not operate due to the difference in CT ratios for high values of short circuit currents. High speed relay element is provided in the Merz Price System.

(b) **CT connections.** Fig. 32.6 gives the connections of CT's for a star side and Fig 32.7 shows connections of a delta side.

— In both cases three current transformers are required at each side of the protected transformer. The connections of CT secondaries are such that during normal conditions and for external faults, no current should flow through the relay operating coils.

There is an inherent phase displacement between vectors representing the voltage induced in high voltage winding and low voltage windings having same marking letter and corresponding neutral points, in case of star-delta transformers. Hence the load currents on H.V. side are displaced in phase with respect to load currents of corresponding phase on L.V. side. The power transformers are grouped according to the phase displacement e.g.,

Group 1 : Star-star, Phase displacement = 0°

Group 2 : Star-star, Phase displacement = 180°

Group 3 : Delta-star, Phase displacement = Minus 30°

Group 4 : Delta-star, Phase displacement = Plus 30°

(Refer. IS : 2026-1962)

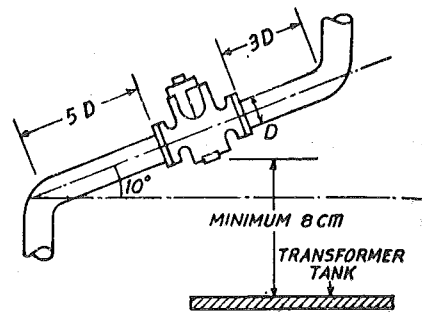

Fig. 32.5. Installation of Buchholz Relay.

In the circulating current differential protection, the phase displacement in line currents on two sides, introduces phase difference in secondary currents of CT's on two sides.

The CT connections should be such that the resultant currents fed into the pilot wires from either sides are displaced in phase by an angle equal to the phase shift between the primary and secondary currents. To get this arrangement, the following rules are followed :

- Secondaries of CT's on star connected side of power transformer are connected in delta (Fig. 32.6).
- Secondaries of CT's connected on delta side of power transformer are connected in star (Fig. 32.7). With such arrangement,

the phase displacement between currents gets cancelled with the phase displacement due to star/delta connections of CT secondaries, and the current fed to pilot wires from both sides are in phase during normal conditions.

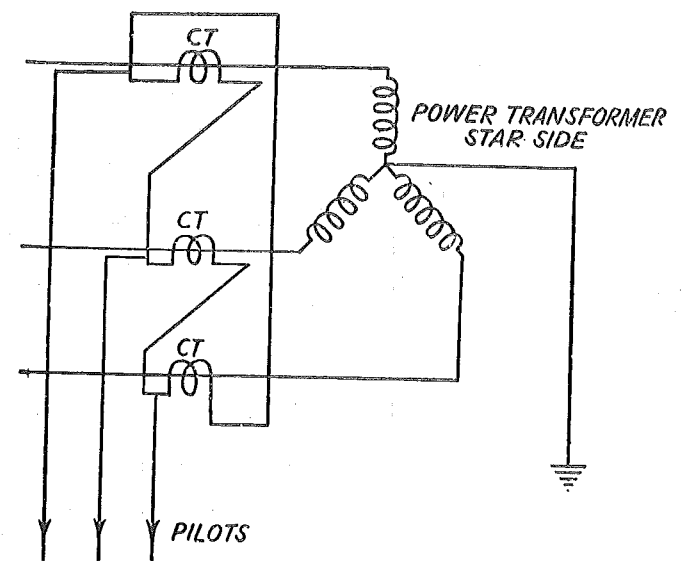

Fig. 32.6. Connection of CT secondaries on star side. (Contd.)

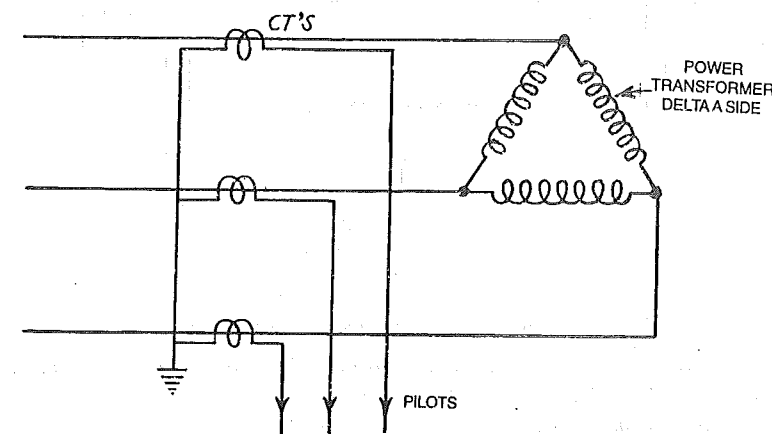

Fig. 32.7. Connections of CT secondaries on delta side.

- The neutrals of CT star and Power Transformer star connections are grounded.
- **CT ratios.** Current ratios of CT's on each side will be different depending upon line currents of power transformer and connections of CT's. The currents fed into pilots from each end should be the same for normal condition. Suppose this current is 5 Amp. then secondary current of delta connected CT will be $5/\sqrt{3}$ Amp. and star connected CT will be 5 Amp.

The star-star transformer comes under group 1 or group 2, having phase displacement of 0° or 180° respectively. The CT secondaries on both sides are connected in delta (Fig. 32.9).

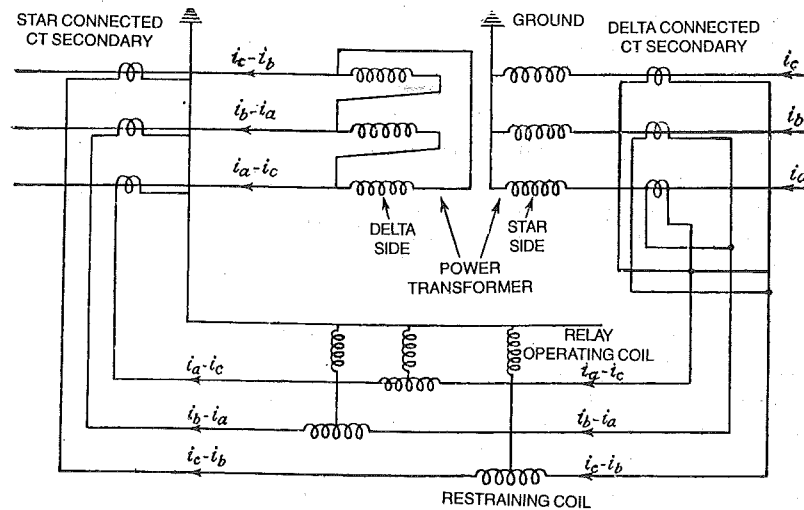

Fig. 32.8. Differential protection of delta Star transformer.

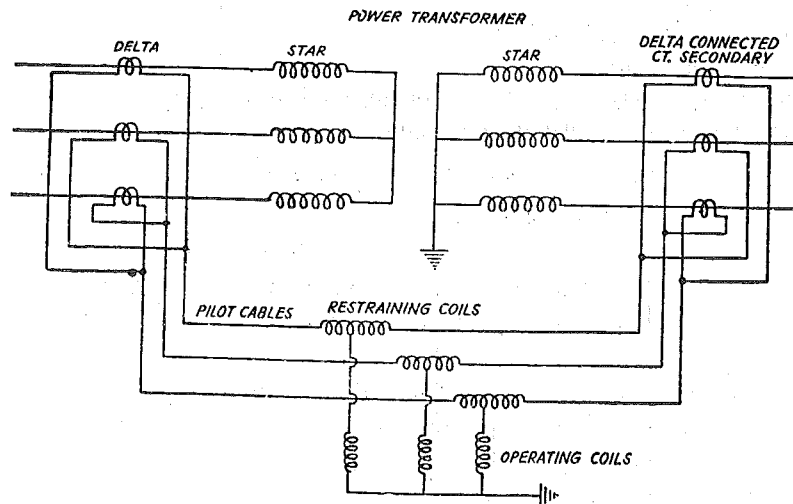

Fig. 32.9. Differential protection of star-star transformer.

Example 32.1. Describe with the help of a neat diagram the connections of differential protection of a transformer. A 3-phase 33/6.6 kV star/delta connected transformer is protected by Differential system. The CT's on LT side have a ratio of 300/5. Show that the CT's on HT side will have a ratio $60 : 5\sqrt{3}$.

Solution. CT's on delta side are star connected. Hence the secondary phase currents are equal to currents in pilot wires. CT's on star connected side are delta connected hence current in secondary is equal to current in pilot wires divided by $\sqrt{3}$.

Assume 300 A is flowing in the lines on LT side

$$\sqrt{3} \times 6.6 \times 300 = \sqrt{3} \times 33 \times I$$

I = Current in HT lines

$$= \frac{6.6 \times 300}{33} = 60A.$$

which is primary current of CT on HT side.

Currents in pilot wires. On the delta side of transformers the CT secondaries are star connected. Their secondary current is 5 Amp. Hence current fed in pilot wires from LT side is 5 Amperes. Same current is fed from CT connections on HT side which are delta connected.

Hence secondary current of CT's on HT side is

$$\frac{5}{\sqrt{3}} \text{ Amp.}$$

Hence CT ratio on HT side is

$$60 : \frac{5}{\sqrt{3}}$$

Example 32.2. A 30 MVA, 11.5 kV/69 kV, star-delta power-transformer is to be protected by differential protection. The high voltage side phase lags behind low voltage side phase by 30° . Formulate the complete differential protection for the transformer by selecting CT ratios, CT connections. The continuous current carrying capacity of restraining coils of the differential relay should not exceed 5 Amp. CT ratio is 3000/5 on 11.5 kV side. Determine CT ratio on 69 kV side.

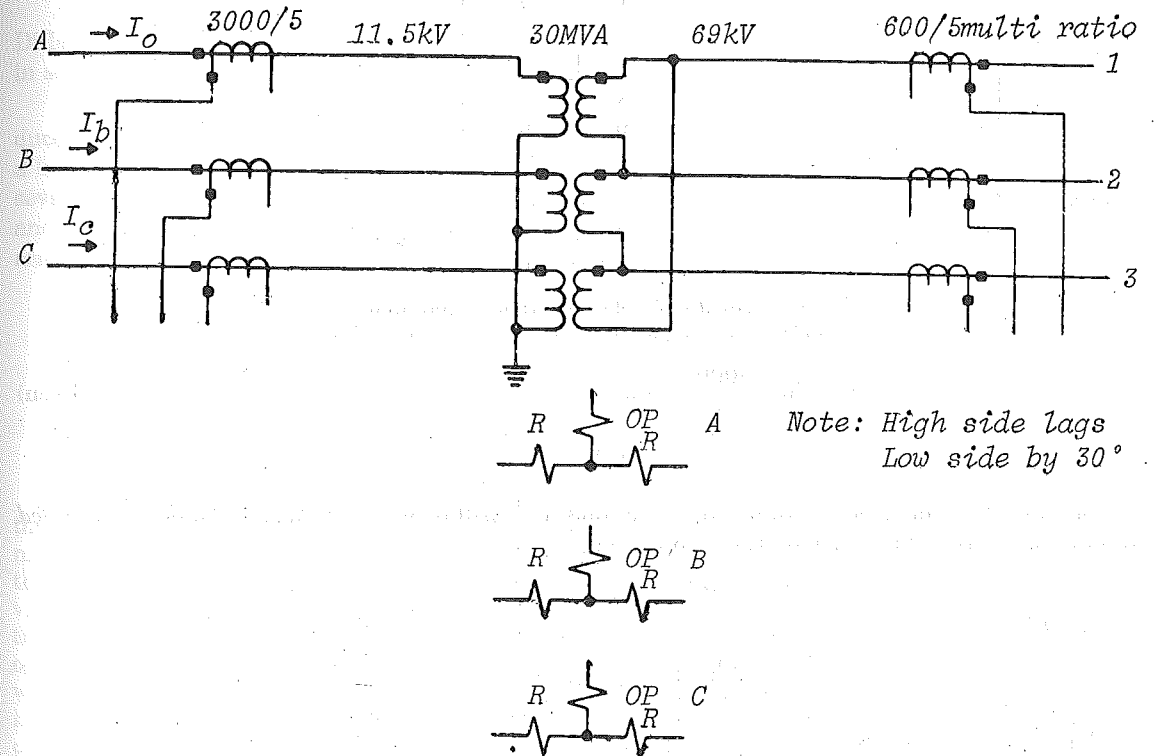

Fig. 32.10. (a) Connecting differential relays.

*Courtesy : Westinghouse Electric Corporation, U.S.A.

***Procedure.** Draw work sheet for connection of differential relays showing the main transformer CT's, operating and restraining coils of CT's (Fig. 33.10). Connect the pilot wires with operating coils and restraining coils as described in the earlier section.

Calculate the full load current of transformer on HV side and LV side. Select CT ratio.

Solution. Calculate full load current for a 30 MVA, 11.5 star/69 delta power transformer.

On 11.5 kV side

$$I_p = \frac{30,000}{\sqrt{3} \times 11.5} = 1505 \text{ A.}$$

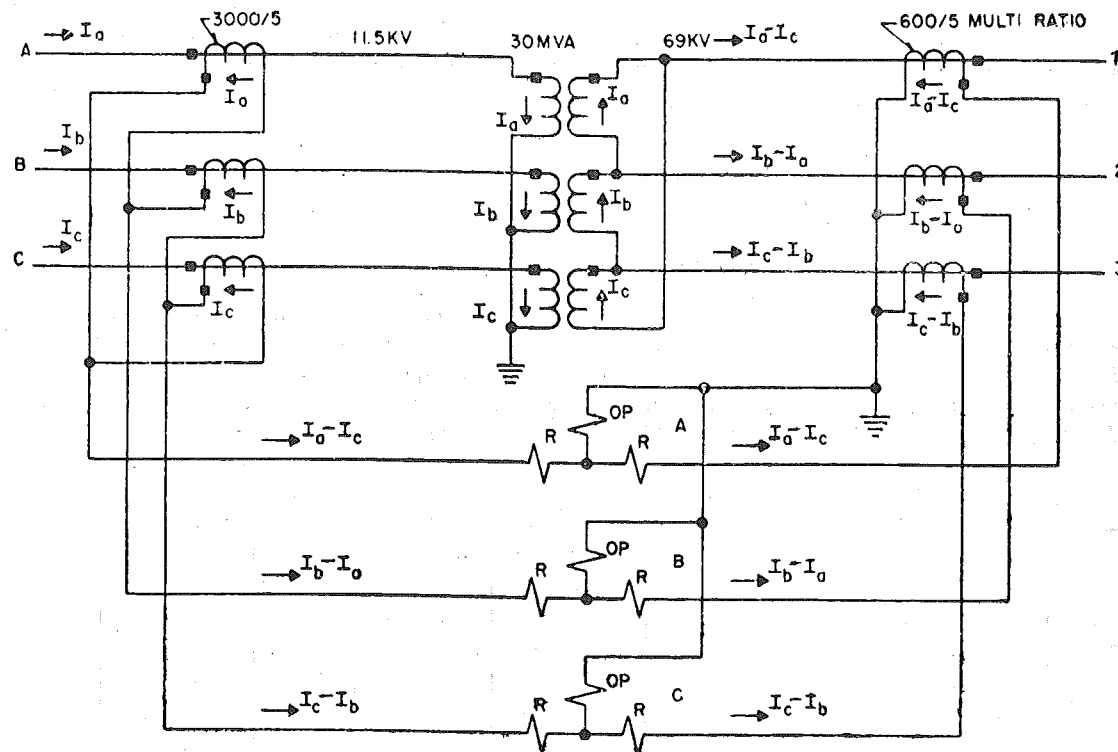

Fig. 32.10. (b) Complete diagram of protection.
*Courtesy : Westinghouse Electric Corporation, U.S.A.

$$CT \text{ ratio} = \frac{3000}{5} = 600$$

...(Given)

$$I_s = \frac{1505}{600} = 2.51 \text{ A.}$$

Since 11.5 kV side is star connected, CT secondaries will be delta connected. Hence current fed into pilot wires from 11.5 kV side CT secondaries is

$$\sqrt{3} \times 2.51 = 4.35 \text{ A.}$$

On 69 kV Side

$$I_p = \frac{30,000}{\sqrt{3} \times 69} = 251 \text{ A.}$$

CT ratio to be selected.

Current in secondary of CT's = Current in pilot wires. Since 69 kV side CT secondaries are connected in star = 4.35 A.

Hence CT ratio = $\frac{251}{4.35} = 57.7$

Select CT ratio 60

Secondary current = 5 A.

Primary current, $60 \times 5 = 300$

CT ratio on 69 kV side = 300/5

Fig. 29.8 (a) and (b) illustrate CT connections.

32.6. PROBLEMS ARISING IN DIFFERENTIAL PROTECTION APPLIED TO TRANSFORMERS

Simple differential protection system is inadequate because the following difficulties arise.

(1) Difference in lengths of pilot wires on either sides of relays. The difficulty is overcome by connecting adjustable resistors to pilot wires. These are adjusted on site to get equipotential points on pilot wires. Taps can be provided on operating coil and restraining coil of relay for adjusting the balance.

(2) Difference in C.T. ratios due to ratio error difference at high values of short circuit currents. Because of this difference the relay operates for through faults. This difficulty is overcome by using biased differential relay for percentage differential relay. In such a relay a restraining coil is connected to pilot wires. The current flowing through restraining coil can be taken as $(I_1 + I_2)/2$.

With increase in through current the restraining torque increases too, and the current due to CT inaccuracy is not enough to cause relay operation. The characteristic of such a relay is given earlier.

(3) Tap changing alters the ratio of voltage (and currents) between H.V. side and L.V. side. Differential protection should be provided with bias (Restrain) which exceeds the effect of variation in secondary current due to tap changing.

(4) **Magnetizing current inrush.** When the transformer is energized, initially there is no induced e.m.f., the condition is similar to switching of an inductive circuit. The resistance being low a large inrush of magnetizing currents takes place. The magnitude of this current inrush can be several times that of load current. The magnitude of inrush currents depends on circuit conditions and voltage at the instant of switching. Maximum peak values equal to 6 to 8 times the rated current can occur.

The factors which influence the magnitude and duration of magnetizing current inrush include :

- size of transformer
- size of power system
- type of magnetic material in the core
- residual flux in the transformer before switching in
- how the transformer is energized.

Maximum inrush current occurs if the transformer is energized when the voltage wave is passing through zero. At this instant, the current and flux should be maximum in highly inductive circuit and in half a wave the flux should change in direction to attain maximum value in the other half-cycles. If there is residual flux in the transformer, the required flux may be in the same or opposite direction. Accordingly the magnetizing current will be less or more. If the magnetizing current is more, it will saturate the core and increase the magnetizing current component further.

The inrush currents decays rapidly for the first few cycles and then very slowly. Sometimes they take 4 to 6 seconds to subside. In high resistance path, the inrush currents decay more rapidly.

The time constant of the circuit (L/R) is not constant because L is variable due to change in permeability of the core material. The losses damp the inrush currents. The time constants of inrush currents vary from 0.2 seconds to 1 minute, depending upon whether the transformer is small or large.

The wave shapes of inrush current in three phases are different as shown in Fig. 32.11.

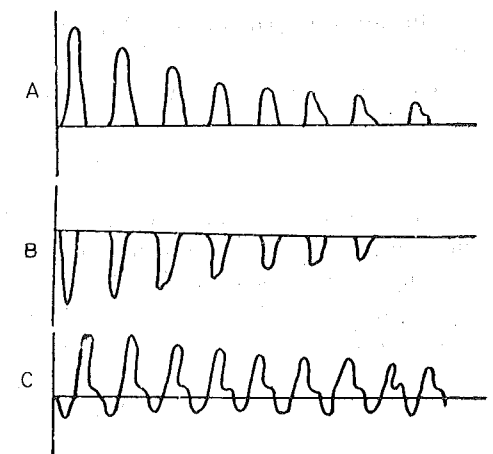

Fig. 32.11. Typical magnetizing current inrush waveforms in three phases.

Inrush currents are seen only by the primary side CTs. They do not reflect on secondary side.

The inrush of magnetizing current will, therefore, cause the operation of differential protection system unless some special modification is done.

Formerly, the relay was provided with time lag of 0.2 second. By this time the inrush will vanish and relay does not trip unnecessary. But what about the protection of the transformer during this period?

While commissioning, one does not know whether there is a fault or not. Providing a time lag is therefore risky. There are several reported incidents that the relay was tripped due to internal fault during switching on for the first time. The engineers thought that the relay has tripped due to magnetizing current inrush. They made the relay in-operative and switched on the transformer. Since there was a fault and relay was inoperative the transformer was damaged.

Next development was desensitizing the relay for short period of 0.1 second during switching. After this time the shunt across the relay coil is removed. This method also leads to the same danger mentioned above. The latest method adopted in transformer protection is *Harmonic current restraint*.

32.7. HARMONIC RESTRAINT AND HARMONIC BLOCKING

The initial inrush of magnetizing currents have a high component of even and odd harmonics. Table 32.3 gives a typical analysis.

Harmonic component of short circuit currents is negligible. This principle is used for restraining the relay from operation during initial current inrush. The harmonic restraint differential relay remains sensitive to fault currents but does not operate due to magnetizing currents.

Table 32.3

Harmonic components in magnetizing current	Amplitude as a % of Fundamental
2nd	63.0
3rd	26.8
4th	5.1
5th	4.1
6th	3.7
7th	2.4

The operating coil of the relay receives fundamental component of current only. The restraining coil receives rectified sum of fundamental and harmonic component.

Thereby, inrush currents having more harmonic content give more restraining torque and the relay does not operate.

Harmonic blocking. The harmonic component of inrush current is used for blocking a separate blocking relay whose contacts are in series with the contacts of the differential relay. The blocking relay contains a 100 Hz blocking filter in operating coil and 50 Hz blocking filter in restraining coil. During inrush currents, the 2nd harmonic component is predominant and the blocking relay is blocked. The blocking relay contacts remain open.

During short circuits, 50 Hz component is predominant. Hence blocking relay operates and relay contact circuit is closed.

32.8. DIFFERENTIAL PROTECTION OF THREE-WINDING TRANSFORMER

The principle of differential protection can be adopted for three winding transformer. (Ref. Fig. 32.12).

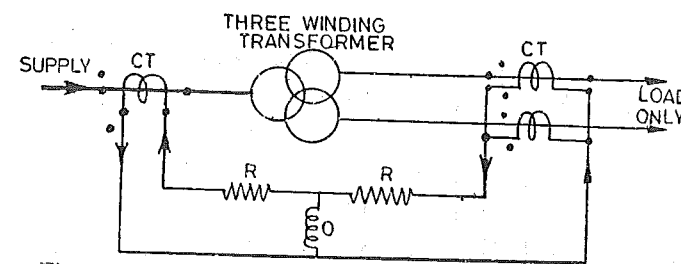

Fig. 32.12. (a) Differential protection of three-winding transformer, feeding loads only. (Single line diagram).

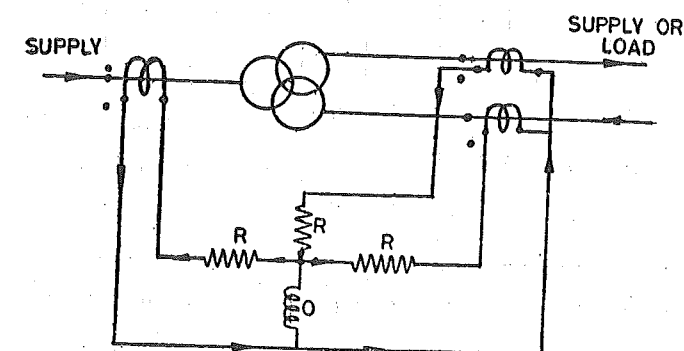

Fig. 32.12. (b) Differential protection of three winding transformer with supply on three side (Single line diagram).

To achieve current balance in pilot wires, ratio adjusting (current balancing) transformers are used in some schemes. The relay unit used in such protection have three restraining coils and one operating coil.

32.9. DIFFERENTIAL PROTECTION OF AUTO-TRANSFORMERS

The principle of differential protection can be applied to three phase auto-transformers. The connections of CT secondaries differs for earth-fault protection alone and combined phase fault and earth fault protection. (Ref. Fig. 32.13).

The Kirchhoff's current law states that the vector sum of component currents entering (or leaving) a point in electric circuit is zero. Thus the CT secondaries can be so connected that during normal condition and external faults, the vector sum of currents in relay operating coil is zero. During internal faults, this balance is disturbed and relay operates.

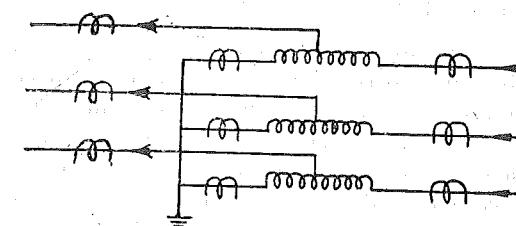
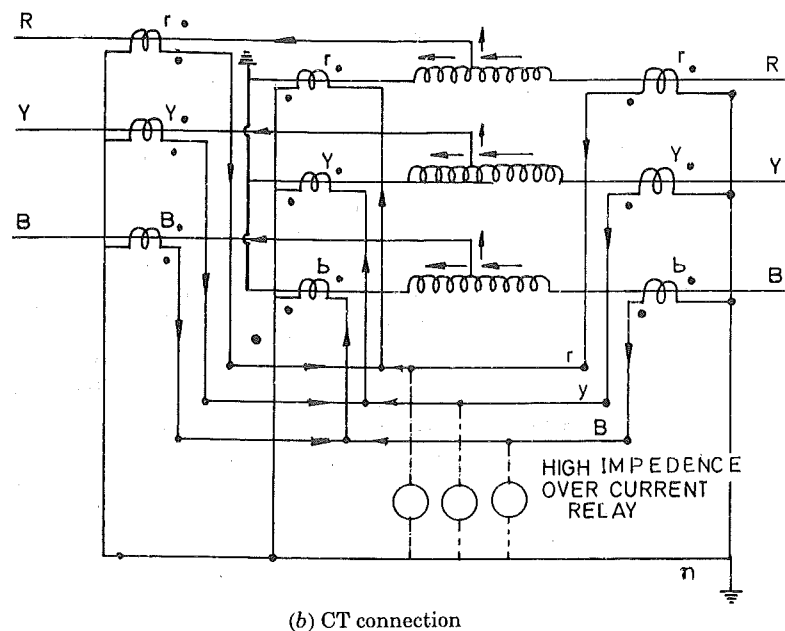

Fig. 32.13. (a) Location of CT's.

Procedure of connections is as follows :

- Draw the diagram of auto transformer. Indicate three sets of CT's [Fig. 32.12 (a)].
- Connect the one end of each set of CT in star.
- Connect other end of each CT of a phase to pilot wire for same phase (say r, y, b).
- Connect star points of CT secondaries to common pilot wire 'n'. Provide one earthing.
- Connect relays between $r-n, y-n, b-n$ of pilot wires.



(b) CT connection
Fig. 32.13. Protection of Auto-transformer from phase faults and earth faults.

32.10. EARTH-FAULT PROTECTION (Refer Sec. 27.6)

- Earth fault protection of transformer can be in one or more forms such as
- restricted earth-fault protection by differential protection (Ref. Sec. 28.3, 33.4).
 - additional/separate restricted earth-fault protection.
 - leakage to frame protection (Ref. Sec. 27.10).
 - neutral current relays (Ref. Sec. 27.7).

Leakage-to-Frame Protection for Small Transformers

Principle explained in Sec. 27.10 can be used for small transformers.

32.11. RESTRICTED EARTH FAULT PROTECTION

Earth fault relays connected in residual circuit of line CT's [Fig. 32.15] give protection against earth faults on the delta or unearthed star connected windings of transformers. Earth faults on secondary side are not reflected on primary side, when the primary winding is delta connected or has unearthed star point. In such cases, an earth fault relay connected in residual circuit of 3 CT's on primary side operates on internal earth faults in primary windings only. Because earth faults on secondary side do not produce zero sequence currents on primary side. Restricted earth fault protection may then be used for high speed tripping for faults on star connected earthed secondary winding of power transformer.

In Fig. 32.16 the star connected side is protected by **Restricted Earth Fault Protection**. An earth fault (F_1) beyond the transformer causes the currents I_2 and I_1 in CT secondaries as shown in Fig. 32.16. Therefore, the resultant current in earth fault relay is negligible.

For earth fault within the transformer star connected winding (F_2), only I_2 flows and I_1 is negligible. Hence I_2 flows through the earth fault relay. Thus restricted earth fault-relay does not operate for earth fault beyond the protected zone of the transformer.

When fault occurs very near the neutral point of the transformer, the voltage available for driving earth fault current is small. Hence fault current would be low. If the relay is to sense such faults, it has to be too sensitive and would therefore operate for spurious signals, external faults

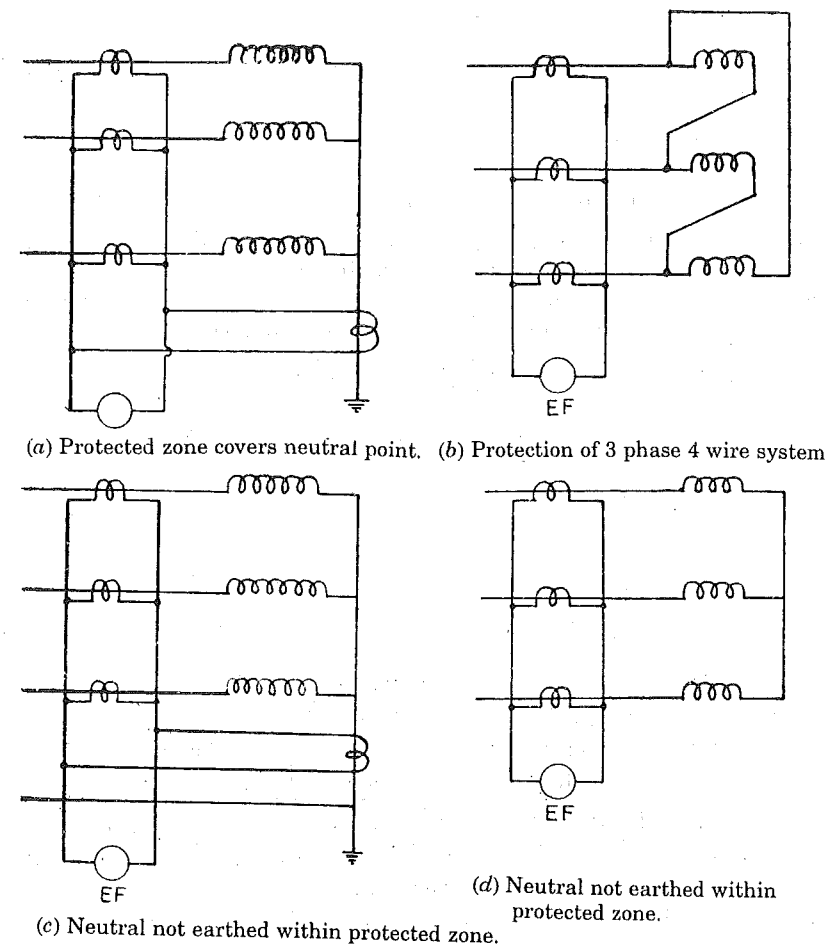

(a) Protected zone covers neutral point. (b) Protection of 3 phase 4 wire system.
(c) Neutral not earthed within protected zone. (d) Neutral not earthed within protected zone.
Fig. 32.15. Restricted earth fault protection (Earth faults with the boundary of CT's are detected).

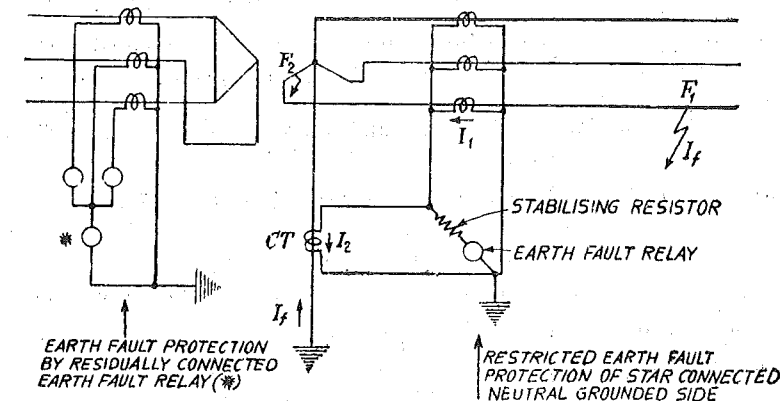

Fig. 32.16. Earth fault protection of transformers.

and switching surges. Hence the practice is to set the relay such that it operates for earth fault current of the order of 15% of rated winding current. Such setting protects restricted portion of the winding. Hence the name restricted earth fault protection (Ref. Sec. 33.4).

32.12. PROTECTION OF TRANSFORMERS IN PARALLEL

The following protections are necessary in case of transformers operating in parallel :

- Overcurrent protection
- Earth-fault protection
- Directional overcurrent and Directional earth fault relays on secondary side to prevent the healthy section feeding into faulty section.

Fig. 32.17 illustrates the scheme. The feedback is prevented by operation of directional overcurrent relay of faster setting. By operation of this directional overcurrent relay, the corresponding CB is quickly tripped and the feedback from healthy section is prevented. The current coils of d.o.c. relay and o.c. relay on secondary side may be connected in series.

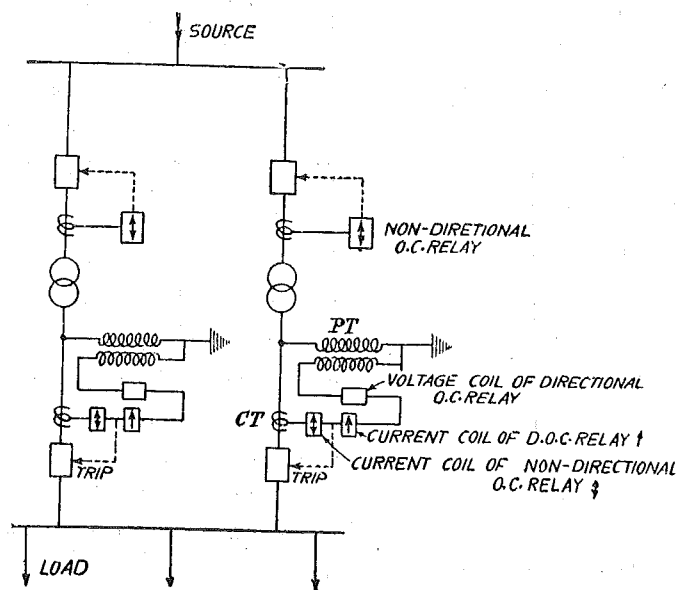

Fig. 32.17. Protection of parallel transformers.

32.13. OVERCURRENT PROTECTION OF POWER TRANSFORMERS

Differential protection is generally uneconomical for power transformers below about 5 MVA. In such cases, overcurrent protection is employed as main protection against phase faults. For transformers above about 5 MVA, if differential protection is used as a main protection, overcurrent protection is used in addition, as a back-up for sustained through faults. Earth fault protection is provided in addition to phase fault protection.

For small distribution transformers below 500 kVA, overcurrent protection may be provided simply by means of fuse on H.V. side, as such transformers are installed in unattended sub-stations, circuit breakers and relays are not provided. [Ref. Fig. 14.12(c)].

External short-circuits (Through Faults)

As per the various standards on distribution transformers, power transformers and regulating transformers, the transformer should be capable of withstanding the mechanical and thermal stresses caused by external short-circuits with following conditions.

- the magnitude of r.m.s. value of symmetrical current in any winding does not exceed 25 times the base current in that winding.
- the duration of external short-circuit is limited to time period indicated in the table. (intermediate values obtained by interpolation)

Table 32.4*

R.M.S. Value of Symmetrical current in a winding (Times base current)	Time period in seconds	Transformer % Impedance
25	2	4
20	3	5
16.6	4	6
14.4	5	7

*Ref. ANSI C 57 12.00 — 1968.

Through faults are not detected by differential protection of transformer. If the through faults persist of longer duration, the transformer gets damaged by thermal stresses. The through faults are detected by overcurrent relays, overcurrent relays with undervoltage blocking, zero sequence protection, negative sequence protection.

The setting of overcurrent protection for through faults covers transformer, station busbar and portion of a transmission line. The overcurrent protection for through faults provides back-up protection to differential protection for internal faults.

The overcurrent due to faults are accompanied by voltage drop, negative phase sequence currents. Earth faults are accompanied by zero phase sequence currents.

32.13.1. Overload Protection

The permissible overload and their duration depends upon the type of cooling and insulation class of transformer. Higher overloads are permissible for a shorter duration (Table 32.5).

Table 32.5. Permissible Duration of Overload

Overload % :	125	150	175	200	300
Duration (Minutes) :	125	45	15	10	1

Hence for sub-station transformers, overload protection is generally arranged to initiate alarm. In unattended stations, overload protection is arranged to trip the breaker after a requisite time delay.

The transformers with utility equipment are prone to sudden overloads. (Furnace transformers, transformers for Motors). The overload protection for such transformers is also given requisite time delay.

While selecting the overcurrent protection of transformer, the following aspects need consideration.

- Magnetizing current inrush: IDMT relays are not affected by the current inrush as they have enough time lag. Instantaneous overcurrent relays should be high set to avoid mal-operation.
- The fault currents on primary side and secondary side of power transformers are different for phase-phase faults. Lower value should be selected for setting of overcurrent relays.
- Primary full load current should be considered while setting the overcurrent relay.
- The setting of IDMT overcurrent relay is generally 125 per cent of transformer rating to take care of normal overloads. Enough time delay should be provided as per the application.
- The setting of instantaneous overcurrent relay on primary side should be more than asymmetrical value of fault current for 3 phase fault on secondary side of transformer. This setting is generally adequate to take care of magnetizing current inrush.
- Same set of current transformers should not be used for differential protection and overcurrent protection.

[Refer Sec. 27.5, 27.7 for connections of overcurrent protection and earth fault protection].

32.14. THERMAL OVER-HEATING PROTECTION OF LARGE TRANSFORMERS

Thermocouples or resistor temperature detectors are kept near each winding. These are connected to a bridge circuit. When temperature increases above safe value, an alarm is sounded. If measures are not taken, the circuit breaker is tripped after a certain temperature. Some typical settings for oil temperatures are as follows :

Switch on fans	:	60°C.
Alarm	:	95°C.
Trip	:	120°C.

Oil Temperature Indicator Thermometer

An oil thermometer, which is common with all oil-filled transformers, can be considered as a partially effective protective device when equipped with alarm contacts connected to give remote warning of abnormally high oil temperature. Its location is such that it naturally monitors the hottest fluid that exists in the transformer. The same thermometer is often used to start fan motors on transformers equipped with automatic air blast to increase the nameplate kVA rating.

The thermometer cannot be relied upon as a fault-detecting device. Transformer oil has a much longer time constant than the windings themselves, hence is many times more sluggish in response to changes in loading losses which directly affect winding temperature. Thus the thermometer's temperature warning will vary between being too conservative or too pessimistic, depending on the rate and direction of change in loading.

Alarm contacts used in conjunction with an oil thermometer are adjustable but are typically set in a sequence that brings on fans at a liquid temperature of 60°C and actuate a switch contact should the temperature reach 90°C. For a typical design in a 30°C ambient, the fans are brought into operation at about 90 per cent rated load whereas the alarm is given at about 130 per cent rated load. These percentages will vary with each manufacture for each design and are dependent upon the actual ambient temperature. The percent loadings will be somewhat lower at ambient above 30°C and higher at ambients under 30°C.

Switches are usually capable of readjustment through a range of $\pm 10^\circ\text{C}$, thus allowing compensation for some of the factors mentioned above.

Hot Spot Thermometer (Winding Temperature Device)

The thermometer bulb is located in a pocket near the winding. The bulb is surrounded by hot circulating oil. The bulb is also heated by a small heater connected across CT secondary. Thereby the heat given to the bulb is a function of load current as well as the temperature of oil near winding. The device is matched with heating curve of the transformer winding.

The reading of hot spot thermometer is related to actual thermal condition of transformer than that of oil temperature indicator. However due to the necessity of closely matching its artificial bimetal gradient to the theoretically hottest spot winding gradient, a short time heavy overload will often register higher on the dial than a long-time light overload.

32.15. OVER-FLUXING PROTECTION

The flux density 'B' in transformer core is proportional to V/f . ($B \propto V/f$). Power transformers are designed to withstand $(V_n/f_n \times 1.1)$ continuously, where V_n is normal highest r.m.s. voltage and f_n is standard frequency. Core design is such that higher V/f causes higher core loss and core heating. The capability for V/f for higher values is limited to a few minutes.

$\frac{v/f}{v_n/f_n}$	1.1	1.2	1.25	1.3	1.4
Duration of Withstand limit (minutes)	Continuous	2	1	0.5	0

High V/f can occur in Generator Transformers and Unit-auxiliary transformers if full excitation is applied to generator before full synchronous speed is reached. V/f relay (Volts/Hertz) relay is

provided in the automatic voltage regulator of generator. The relay blocks and prevents increasing excitation current before full speed and frequency is reached.

In V/f relay, a resistance and capacitance are connected to secondary of VT. The voltage drop across the resistance is a function of V/f , where V is the line to earth voltage and f is frequency. This voltage is fed to the volts 'per Hertz' relay.

The magnetic flux density in the transformer core is a function of V/f . Hence the relay senses magnetic flux condition. Overfluxing relay is provided with enough time lag. Overfluxing relay is not necessary for substation transformers. In substations, V/f relays are provided for load shedding (Sec. 45.7)

32.16. PROTECTION OF ARC FURNACE TRANSFORMERS

Furnace transformers are subjected to repeated short circuits during the melting process. Inverse time overcurrent relays are provided for both phase faults and earth faults.

Induction type inverse overcurrent-relays are used for short circuit and overcurrent protection of Furnace Transformer. The setting is such that for current of the order 300 to 400 per cent of full load current, faster tripping is obtained. For overcurrent of the order of 150 per cent, enough time delay provide so that the relay does not trip during normal current surges.

The time delay should be such that the relay should not operate during initial magnetizing current inrush. High speed overcurrent relays are provided on secondary side. These are set to pick up instantaneously for currents more than full load secondary current but slightly less than the corresponding setting on relays on HT side.

Backup breaker is provided in the main sub-station which is set to interrupt short circuits in the HT side of the furnace transformer.

Differential protection schemes have been developed for arc furnace transformers and have been used in several installation.

32.16.1. Power Supply Requirements of Arc Furnace Plants

While selecting the power supply for an arc furnace plant the fault level at the point of connection of the furnace should be adequate. Hence, the power line should be taken from the sub-station bus having adequate fault level. If the fault at a bus is inadequate the power should be taken from the bus of yet higher voltage level, having desired fault level. The expression given below can be taken as a guide rule.

$$S_a = K \cdot 80, T \text{ mva}$$

where S_a = Fault level at the point of connection of furnace transformer (MVA)

$T \text{ mva}$ = Nominal rating of furnace transformer (MVA)

K = Multiplying factor to take into account, the number of arc furnaces in the plant

$K = 1$ for one furnace

$A = 1.2$ for two furnaces

Choice of Voltage. The choice of voltage for feeding the arc furnace plant is determined by the voltage-levels of the buses in the sub-station and their fault levels. The fault level requirements of the supply are calculated as described above.

kVA Rating of Intermediate Step-down Transformer that feeds that arc furnace plant.

The furnace transformers are given a nominal kVA rating such that they can be safely overloaded by about 20% during the melt down periods. In other words :

$$(T \text{ mva}) \text{ max} = 1.2 (T \text{ mva}) \quad \dots(2)$$

where, $(T \text{ mva})$ = Nominal MVA rating of the furnace transformer.

$(T \text{ mva}) \text{ max}$ = The rated apparent power the furnace transformer can supply.

*Overvoltage relays should be provided in bus-bar protection to avoid transformer failure do to temporary overvoltage.

32.17. PROTECTION OF RECTIFIER TRANSFORMER

Protection of rectifier transformer depends upon type and class of rectifier *i.e.* whether diode or thyristor rectifier. Static relays having characteristics closely matching the overload characteristics of the rectifier are preferable. The general practice is as follows :

- Overload protection. Very inverse or extremely inverse over-current relay for protection of rectifier transformer.
- Faults in rectifier : (a) HRC fuses for protection of rectifier
(b) Overload relays on primary side of transformer as a backup.

32.18. PROTECTION OF GROUNDING TRANSFORMER

The CT secondaries are delta connected. An overcurrent relay with time lag is inserted in the delta. The zero sequence currents circulate in this delta. The time setting of this relay is selected to co-ordinate with thermal rating of the earthing resistor (if used) or with time setting of other earth fault relays. The earthing transformer is disconnected by opening the circuit-breaker, on a persistent earth fault.

The other three relays provide protection against faults in the grounding transformer. These are instantaneous relays, set between 25 to 50 per cent of continuous current-rating of grounding transformer. Buchholz relay is also used. Earth fault protection is provided by residually connected relay (not shown in the figure).

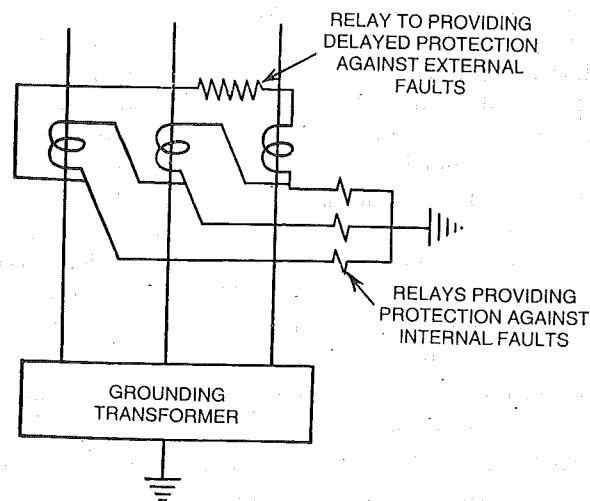

Fig. 32.18. Protection of grounding transformers.

SUMMARY

The protections provided for a transformer are summarised in Tables 32.1 and 32.2.

Buchholz relay is used transformers with conservators. It is connected in the pipe between the tank and the conservators. It gives an alarm on incipient faults below oil level.

Differential protection is used for phase to phase and phase to ground faults. Harmonic restraint is used for preventing the relay operation due to magnetizing current inrush during switching. Biased or percentage differential relaying is used to prevent wrong operation due to inaccuracies of CT ratios. The secondaries on star connected side are connected in delta. The secondaries on delta connected side are connected in star.

Restricted earth fault protection is provided to prevent operation on external earth faults and to give sensitive earth fault protection.

The overload protection is given by overcurrent relays and thermal relays. V/f relays are for overfluxing protection and surge arresters for protection against switching/lightning surges.

QUESTIONS

1. With the help of net sketches explain the protections of a star-delta power transformer, against the following abnormal conditions :
(a) Phase to phase fault (b) Earth fault (c) High voltage surges.

2. Describe the principle of Differential System of Protection applied to a power transformer. What are the difficulties experienced and how are they overcome?
3. Explain the meaning of percentage differential protection. Why is it necessary to provide a bias coil?
4. Explain why densensitizing of relay was not satisfactory process in transformer protection. What is the principle of Harmonic Restraint?
5. What is the meaning of restricted earth fault protection? A 10,000 kVA, 11/6.6 kV transformer has 11 kV star connected side. The neutral point is earthed through an impedance. Calculate the impedance magnitude to provide protection to 90% winding from phase to earth fault.
6. A star-delta, 11kV/6.6kV transformer is protected by means of Differential Protection system. The 6.6 kV delta is connected side has CT of ratio 600/5. Calculate CT ratio of HT side.
7. Describe the principle of Differential Protection system applied to Delta-Star connected transformer.
8. Describe in brief the various protections to be provided to a 20 MVA transformer and a 250 kVA Transformer.
9. Explain the Buchholz relay with reference to
(a) Principle of operation (b) Installation
(c) Difficulties (d) Merits
(e) Limitations.
10. Distinguish between :
(a) Through faults and internal faults. (b) Incipient faults and serious faults.
11. Write notes on :
(a) Protection of Arc Furnace Transformer. (b) Harmonic Restraint
(c) Overfluxing Protection.
12. The bus bar voltage of a 220 kV substation shot-up to 280 kV while frequency was 48 Hz. Which protections would operate and protect the 220 kV/110 kV power transformers in the substation?

Protection of Generators

Introduction — Protection Chart — Faults on Generator — Differential Protection of Generator — Problems — Turn to turn Fault — Stator Overheating — Reverse Power — Rotor Earth Fault — Field Suppression — Unbalanced Loads — Back-up Protection — Overspeed — Bearing Insulation — Protection of Large Generator — Transformers Units — Protection of small standby Generators — Summary.

33.1. INTRODUCTION

Protection of turbo-generators is the most complex and elaborate. The reasons being the following :

- Generator is a large machine and is connected to busbars. It is accompanied by unit-transformers, auxiliary transformer and bus system.
- It is accompanied by excitation system, prime mover, voltage regulator, cooling system etc. Hence it is not a single equipment. The protection of generator should be co-ordinated with associated equipment.
- It is a costly and important equipment. It should not be shut off as far possible because that would result in power shortage and emergency.

Modern Turbo-generators have the following typical ratings.

60 MW	11.8 kV
120 MW	13.8 kV
500 MW	22 kV

Generator unit upto 500 MW have been installed in India.

1000 MW unit capacity Turbo-generators has been installed in U.K. during 1970's.

A generator is protected against several fault. Table 33.1 gives data about the present practice of alternator protection. Several other abnormal conditions give an alarm and indication. Static protection schemes have been developed for generator protection.

Table 33.1. Generator Protection

	Below 1 MW	Above 1 MW	Above 10 MW	Above 100 MW
1. Differential			*	*
2. Restricted earth fault			*	*
3. Stator turn to turn fault				*
4. Time over current	*	*		
5. Temperature (Thermo-Detector)		*	*	*
6. Negative sequence current		*	*	*
7. Loss of load			*	*
8. Loss of input-anti-motoring		*	*	*
9. Loss of field			*	*
10. Loss of synchronism			*	*
11. Overspeed	*			
12. Over-voltage	*			
13. Rotor-earth Faults			*	*
14. Back-up overcurrent	*	*	*	*
15. Bearing temperature			*	*
16. Bearing insulation		*	*	*

In unit system of generator connection, generator is connected to LV side of the main step-up transformer and H.V. side of unit auxiliary step-down transformer (Fig. 33.1). The H.V. side of the main transformer is connected to bus *via* switchgear, from where power is transmitted into the Grid. The unit auxiliary transformer feeds the power to the auxiliaries directly, concerned with the unit. The generator and main transformer form a 'unit' and each unit has a boiler, turbine, condenser and other auxiliary systems.

While selecting the scheme for generator protection, the protection of the complete unit and the stability of the system due to disturbance, in the generator should be considered in addition to the protection of the generator itself.

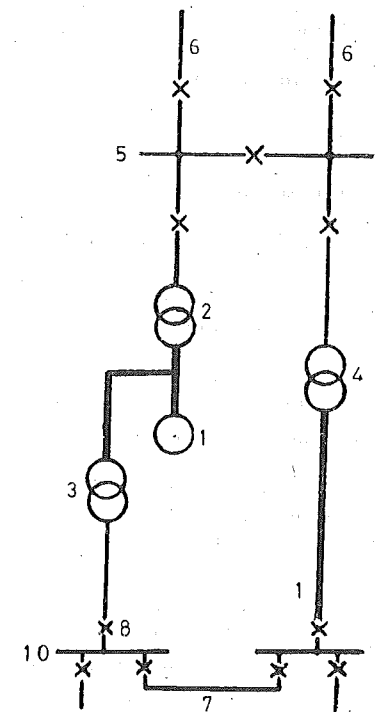

1. Generator (Indoor)
2. Main Transformer (Outdoor)
3. Unit auxiliary transformer (Usually outdoor)
4. Station Service Transformer. (Usually outdoor)
5. H.V. bus. (Outdoor)
6. Transmission line. (Outdoor, overhead)
7. Inter-connection between the Unit Auxiliary Switchgear and Station Service Switchgear.
8. Circuit Breaker. (Indoor)
9. Station Service Switchgear. (Indoor)
10. Unit Auxiliary Switchgear. (Indoor)

Fig. 33.1. Generator connections in unit system. (Refer Table 33.2).

The protection of generator-transformer unit can be divided into three groups :

- Protective relays to detect faults or abnormal conditions external to the unit.
- Protective relays to detect faults internal to the unit.
- Devices associated with the unit *e.g.*, over-speed safeguards, temperature measuring devices for bearings, windings etc. Some of these would an alarm and some cause tripping.

The protection of a large Generator-Transformer unit can be grouped as follows :

- Preventive measures forming part of the generator protection scheme, indicating systems and alarms.
- Protective systems for generator-transformers together.
- Protective system for generator.
- Protective systems for main transformer.
- Protective systems for unit-auxiliary transformer.

(Refer Table 33.1, 33.2). (Refer Sec. 17.5).

33.2. ABNORMAL CONDITIONS AND PROTECTION SYSTEMS (Ref. Table 33.3).

Table 32.2. Protection of Large Generator-Transformer Unit

Protection of Generator Transformer together	Generator-transformer overall differential protection
Generator protection	Generator differential protection* Stator earth fault protection** Negative phase sequence protection*** Against-unbalanced loading Inter-turn fault protection Reverse power protection Field failure protection Rotor earth fault protection*** Temperature sensors in slots Overcurrent relays in stator and rotor circuits Surge arresters for surge overvoltage R-C Surge suppressors
Protection of unit auxiliary transformer	Differential protection* Restricted earth fault protection* Buchholz relay Overcurrent protection, overvoltage protection Winding and oil temperature sensors
Protection of main transformer	HV Overcurrent Protection, overfluxing protection HV Restricted earth fault protection Buchholz relay Winding and oil temperature sensors Surge arresters on HV side
Preventive measures — Sound alarm on control panel	Continuous monitoring of outlet temperature of gaseous of liquid coolants Flow monitors Low boiler pressure alarm/trip Lubrication oil failure Emergency trip Low vacuum

* Trip generator c.b. close throttle valves, opened field c.b., one auxiliary c.b.

** Close emergency throttle valves main c.b. opened only after operation of interlock reverse power relay.

*** Trip main circuit breaker only. (Refer Fig. 33.1).

33.2.1. External Faults.

During external faults with large short-circuit currents, severe mechanical stress will be imposed on the stator windings. If any mechanical defects already exist in the winding, these may be further aggravated. The temperature rise is however, relatively slow and a dangerous temperature level may be obtained after about 10 seconds. With asymmetrical faults, severe vibrations and overheating of the rotor may occur.

The external faults such as faults on bus-bars are not covered by generators protection zone. Hence differential protection of generator does not responds to external fault.

The *overcurrent and earth fault protection of generator* provides back-up protection to external faults, while the primary protection as provided by the protective system of respective equipment (e.g. bus-bars, transmission lines).

33.2.2. Thermal overloading.

Continued overloading may increase the winding temperature to such an extent that the insulation will be damaged and its useful life reduced.

Temperature rise can also be caused by failure of cooling system. In large machines thermal elements (thermo-couples or resistance thermometers) are embedded in the stator slots and cooling system.

The electrical overcurrent protection is generally set at higher value for responding the excessive overloads. Hence it cannot sense the continuous overloads of less value. Neither can it sense the failure of cooling system.

33.2.3. Unbalanced loading.

Continued unbalanced loads, equal to or more than 10 per cent of the rated current cause dangerous heating of the cylindrical rotor in turbo-generators. Salient pole rotors in hydro-generators often include damper windings and are, therefore, much less affected by unbalance loading (negative phase-sequence currents).

Unbalanced loading on generator can be due to

- unsymmetrical faults in the system near the generating station.
- mal-operation of a circuit-breaker near generating station, the three phases not being cleared.

Negative sequence protection senses unbalanced loading of generators.

33.2.4. Stator Winding Faults.

Stator winding faults involve armature winding and must therefore be cleared quickly by complete shutdown of the generator. Only opening the circuit does not help since the e.m.f. is induced in the stator winding itself. The field is opened and de-energized by "Field Suppression" (Ref. Sec. 33.16).

The stator faults include.

- (1) Phase-to-phase faults.
- (2) Phase-to-earth faults.
- (3) Stator inter-turn faults.

Phase to phase faults and phase inter-turn faults are less common. Inter turn faults are more difficult to be detected.

Phase to Earth faults. These faults normally occur in the armature slots. The damage at the point of fault is directly related to the selected neutral earthing resistor. With fault currents less than 20 A, negligible burning of the iron core will result if the machine is tripped within some seconds. The repair work than amounts to changing the damaged coil without restacking of core laminations.

If, however, the earthing resistor is selected to pass a much larger earth-fault current (> 200 A) severe burning of the stator core will take place, necessitating restacking of laminations. Even when a high speed earth-fault differential protection is used, severe damage may be caused owing to the large time constant of the field-circuit and the relatively long time required to completely suppress the field flux. In the case of high earth-fault currents it is therefore normal practice to install a circuit breaker in the neutral of the generator in order to reduce the total fault-clearance time.

Circulating current biased differential protection provides the earth fault protection. However the sensitivity of such a protection for earth faults depends upon the resistance in neutral to earth connection and the position of earth fault in the winding.

A separate and *sensitive earth fault protection* is generally necessary for generators with resistance earthing.

Phase to phase faults. Short circuits between the stator windings very rarely occur because the insulation in a slot between coils of different phases is at least twice as large as the insulation between one coil and the iron core. However a phase to earth fault may cause a phase-to-phase fault within the slots. If a phase-to-phase fault should occur, this is most likely to be located at the end-connections of the armature windings, i.e. in the overhanging parts outside the slots. A fault of this nature causes severe arcing with high temperatures, melting of copper and risk of fire if the insulation is not made of fire-resistant, non-flammable material. Since the short-circuit currents in this case do not pass *via* the stator core, the limitations will not be particularly damaged. The repair work may therefore be limited to replacing the affected coil and mechanical parts of the end-structure.

With acknowledgements to ASEA Sweden ; Brown Boveri, Switzerland.

Circulating current biased differential protection gives adequate and fast protection against phase-to-phase faults in the generator zone. (Ref. Sec. 33.3).

— **Stator Inter-turn faults.** Short circuits between the turns of one coil may occur if the stator winding is made up of multiturn coils. Such faults may develop owing to incoming current surges with a steep wave-front which may cause a high voltage ($L di/dt$) across the turns at the entrance of the stator winding.

If, however, the stator winding is made up of single-turn coils, with only one coil per slot, it is, of course, impossible to have an inter-turn fault. If there are two coils per slot the insulation between the coils is of such dimensions that an inter-turn fault is not likely to occur.

For large machines (> 50 MVA), it is the normal practice in some countries to use single-turn coils whereas in the U.S.A. and Canada multi-turn coils are used. In the latter countries, therefore, the inter-turn, or split-phase, protection has become very popular.

Differential protection and overcurrent protection does not sense inter-turn faults. *Stator interturn fault protection detects the inter-turn faults.*

33.2.5. Field Winding Faults.

Rotor faults include rotor inter-turn fault and conductor-to-earth faults. These are caused by mechanical and temperature stresses.

The field system is normally not connected to the earth so that a single earth fault does not give rise to any fault current. A second earth fault will short circuit part of the winding and may thereby produce an unsymmetrical field system, giving unbalanced force on the rotor. Such a force will cause, excess pressure on bearing and shaft distortion, if not cleared quickly.

The unbalanced loading on generator gives rise to negative sequence currents which cause negative sequence component of magnetic field. The negative sequence field rotates in opposite direction of the main field and induces e.m.f.'s. in rotor winding. Thus the unbalanced loading causes rotor heating.

Reduced excitation may occur due to short circuit or an open circuit in field or exciter circuits or a fault in automatic voltage regulator. If the field circuit breaker opens by mistake, the fully loaded generator falls out of step within 1 second, and continues to run as an induction generator drawing reactive power from the bus. To avoid this, a tripping scheme is so arranged that opening of field circuit breaker causes the tripping of generator unit breaker.

'Rotor earth fault protection' is provided for large generators.

Rotor temperature indicators are used with large sets for detecting rotor overheating due to unbalanced loading of generator.

33.2.6. Overvoltages (Ref. Sec. 18.11)

Atmospheric surge-voltages are caused by direct lightning strokes to the aerial lines in the H.V. system. Induced and capacitively transferred voltage surges can, however, reach the generator via the unit transformer. The amplitude and the duration of the surge on the generator side depends on the type of lightning arresters used on the H.V. side and also on the actual configuration of the H.V. busbar.

To protect generators from severe voltage surges, surge arresters and surge capacitors and often used. In the case of smaller machines directly connected to a distribution network comprising overhead lines, such protective devices are of prime importance.

Switching Surges. Switching operations may cause relatively high transient overvoltage if restriking occurs across the contacts of the circuit-breakers. These transients are similar to those obtained during intermittent earth faults (arcing grounds) and may be limited by using modern circuit-breakers.

Arcing Grounds. The amplitude of the transient voltages during arcing grounds may theoretically, under the most unfavourable conditions of arc-restriking, reach a value of 5 times normal line to neutral peak voltage. By means of the resistance earthing of the generator neutral these over-voltages will be reduced to a maximum value of about 2.5 times the rated peak voltage. In the case of generator-transformer units, stray voltages may appear at the generator neutral during an earth fault in the HV network. This is due to the capacitive coupling between the HV and LV windings of the step up transformer. The magnitude of these stray voltages depends on: (a) the method of neutral earthing of the HV network, i.e., effectively earthed or reactance earthed (Petersen-coil)

and (b) the step up transformer inter-winding capacitance, and (c) the ohmic value of the generator neutral earth resistor.

When the HV system is directly earthed, the voltage across the generator earthing resistor, during an HV earth fault will be small and can normally be disregarded. However, if the HV network is Petersen coil earthed, the neutral displacement voltage of the generator can reach the normal setting of the earth fault protection. This problem must therefore be investigated for each particular installation, and can be solved by either increasing the earth-fault relay setting or reducing the ohmic value of the generator earthing resistor.

Surge arresters and R-C surge suppressors installed between the generator circuit-breaker and the generator may also assist in reducing some of the highest switching surges. (Ref. Sec. 18.12)

Specially developed indoor type surge arresters are connected near generator terminals. These comprise three star connected unit plus another unit between star point and earth and thus provide overvoltage protection for all phases and between phases. Capacitors rated about 0.1 μF to earth are fitted to absorb surge voltages.

33.2.7. Other Abnormal Conditions.

Loss of excitation results in loss of synchronism and slightly increased speed. The machine continues to run as an induction generator, drawing excitation current from bus bars, the damper winding acts like a squirrel cage. The currents are taken at a high lagging power factor and magnitude is of the order of full load current. This causes overheating of stator winding and rotor winding. This condition should not be allowed to persist for a long time. The field should be either restored or the machine should be shut off, before system stability is lost.

Field-failure protection or loss of field protection is provided for generators. (Ref. sec. 33.13).

In addition to the above mentioned electrical faults, the running of a machine can be endangered by relatively minor mechanical defects in any of the auxiliary apparatus associated with the prime mover.

Loss of Synchronism. If the machine loses synchronism with respect to the network after a short circuit has been interrupted, a certain amount of slip is generally permissible, providing that the stator current does not exceed 85% of the maximum asymmetric short current with a solid short-circuit at the terminals.

Wrong Synchronization. Present day requirements stipulate that a generator must be short-circuit proof. However, with low reactance of the network and at the unit-connected transformer, in the event of wrong synchronization the current can be higher than under short-circuit conditions. This is not permissible. In other words wrong synchronization must not occur. Preventive measures must therefore be taken. In particular, uncontrolled reclosure after complete isolation of the generator from the network must be avoided because this quickly results in an excessive phase angle. In this connection it must also be noted that the recovery voltage in the network following interruption of a short circuit can lead to considerable stresses.

Asynchronous Running without Excitation. If asynchronous running is permitted by the manufacturer and requested by the operator for emergency conditions, it must be monitored. It must be decided whether asynchronous running is to be carried out with open or short-circuited rotor. Slip and stator current must not be allowed to exceed the specified limits.

Local Overheating. Local overheating can occur in generators for various reasons and it is often a difficult matter to locate these with the usual protection equipment. Normally, emission products, in the form of gas, mist or smoke escape and these can be used for tripping a signal. An analysis of these products provides a basis for decision.

Leakage in Hydrogen Circuit. Hydrogen losses are predetermined on the basis of gas consumption. However, continuous direct display is not recommended because temperature fluctuations in the generator cause variations in pressure and therefore gas make up is not directly related to losses. Consequently, long term monitoring is more suitable. It is only hydrogen leakage into the pure water system which is detected separately by the gas blow-off device in the pure water tank. Other points of leakage are not directly detected. It is essential for adequate ventilation to be provided in the vicinity of the generator and terminal box. Special attention must be paid to the

cooling water circuit because any hydrogen carried along by the water is a danger factor and must therefore be prevented.

Moisture in the Generator Winding. Moisture in the generator is to be avoided. Moisture detectors and drains must be provided at all points where liquids can collect. The situation can arise where the make up hydrogen is moist and can thus introduce moisture into the generator even if the cooling water circuits are absolutely leakproof. This can be overcome by a gas drying plant which must be kept operational by the staff.

Oxygen in Pure Water Circuit. Dissolved oxygen in the pure water circuit leads to wear at the copper of the hollow conductors of windings with direct cooling. At hydrogen cushion of adequate pressure in the pure water compensating tank reduces the oxygen content to a minimum. Continuous supervision of oxygen content thus becomes superfluous.

Overspeeding may occur as a result of a fault in the turbine governor or its associated equipment. If the main generator circuit-breaker is tripped while full electrical power is being delivered to the network, dangerous overspeeding is prevented by the normal actions of the governor. It is essential, therefore, that the normal working of the governor be supervised by some additional protective devices. Over-frequency and Under-frequency Protection : Ref. Ch. 45.

Motoring of generator will occur if the driving torque of the prime mover is reduced below the total losses of the turbo-generator unit. Active power will then be drawn from the network in order to maintain synchronous running, and the generator will work as a synchronous motor. If this is allowed to persist (> 20 seconds), serious over-heating of the steam turbine blades may occur, depending on the type turbine and the design limits imposed by the manufacturer.

Table 33.3. Some Abnormal Conditions and Protection Systems

S.No.	Abnormal Condition	Effect	Protection
1.	Thermal overloading — continuous overloading — failure of cooling system	Overheating of stator winding and insulation failure.	Thermocouples of resistance thermometer imbedded in stator slots and cooling system. Stator over-load protection with overcurrent relays.
2.	External fault fed by generator	Unbalanced loading stresses on winding and shaft, excessive heating for prolonged short-circuit.	Negative phase sequence protection for large machines. Overload protection for small generators.
3.	Stator faults — phase to phase — phase to earth — inter-turn	Winding burn-out, welding of core laminations, shut down.	Biased differential protection, sensitive earth-fault protection, interturn fault protection.
4.	Rotor earth faults	Single fault does not harm second fault causes unbalanced magnetic forces causing damage to shaft, bearings.	Rotor earth-fault protection.
5.	Loss of field — Tripping of field circuit-breaker.	Generator runs as induction generator deriving excitation currents from bus-bar. Speed increases slightly.	'Loss of field' or 'Field failure' protection.
6.	Motoring of generator. When input to prime mover stops, the generator draws power from bus-bars and runs a synchronous motor in the same direction.	Effect depends upon type of prime mover and the power drawn from the bus during motoring.	Reverse power protection by Directional power relays direct the reversal of power.
7.	Over-voltages.	Insulation failure	Lightning arresters connected near generator terminals.
8.	Over-fluxing of Generator Transformer and Auxiliary Transformer	Heating of core	V/f relay. Connected in voltage regulator circuit generator.
9.	Under-frequency	Failure of blades of steam turbines	Frequency Relays (Ref. Ch. 45)

Reverse-power protection achieved by directional power relays are incorporated in the generator protection scheme. (Ref. Sec. 26.16).

Vibrations may occur owing to unbalanced loads or certain types of mechanical faults. Vibration detectors are usually mounted on the generator bearing pedestal.

Excessive bearing temperature may arise due to mechanical faults, impurities in the lubricating oil or defects in the oil circulation system. These fault may be detected by means of a temperature monitoring device embedded in the bearing.

Bearing Current. An induced e.m.f. of some volts may be developed in shaft of a generator owing to certain magnetic dissimilarities in the armature field. If the bearing pedestals at each side of the generator are earthed, the induced e.m.f. will be impressed across the thin oil films of the bearings. A breakdown of the oil-film insulation in the two bearings can give rise to heavy bearing currents owing to the very small resistance of the shaft and the external circuit thus developed.

Consequently, the bearing pedestal farthest from the prime mover is usually insulated from earth and the insulation supervised by a suitable relay. Further, to prevent the rotor and the shaft from being electrostatically charged, the shaft is usually earthed *via* a slipring and a 200 ohm resistor. This resistor also contributes by taking the injected a.c. leakage current of the field circuit earth-fault protective scheme.

33.3. PERCENTAGE DIFFERENTIAL PROTECTION OF ALTERNATOR STATOR WINDINGS

(Also called Biased Differential Protection or Merz-Price Protection) (Ref. Ch. 28).

(a) **Principle.** The differential protection is that which responds to the vector difference between two or more similar electrical quantities. In generator protection, the current transformers are provided at each end of the generator armature windings. When there is no fault in the windings and for through faults, the currents in the pilot wires fed from CT connections are equal. The differential current $I_1 - I_2$ is zero. When fault occurs inside the protected winding, the balance is disturbed and the differential current $I_1 - I_2$ flows through the operating coil of relays causing relay operation. Thereby the generator circuit-breaker is tripped. The field is disconnected and discharged through a suitable impedance (Ref. Ch. 28).

(b) **Connections of CT's for differential protection of generator.** Fig. 33.2 illustrates connection of CT's for a star-connected generator. Fig. 33.3 illustrates connections for a delta connected generator.

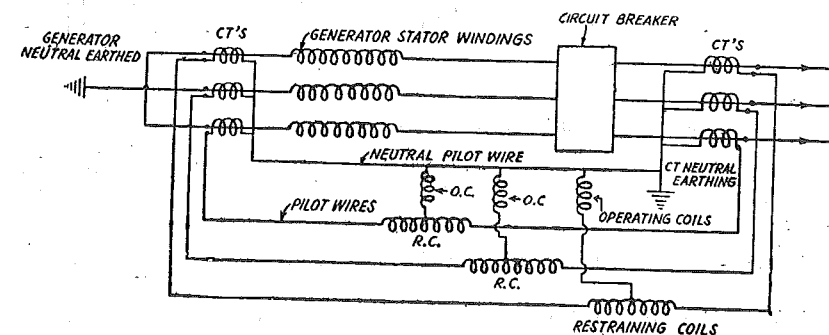

Fig. 33.2. Percentage differential relaying of a star connected generator, for phase-phase faults.

The percentage differential relay has an operating coil and a restraining coil, one for each phase. The restraining coil is connected centrally in pilot wires. The operating coil is connected between mid-point of restrains coil neutral pilot wire (Ref. Sec. 28.4).

The CT connections are as shown in Fig. 33.3.

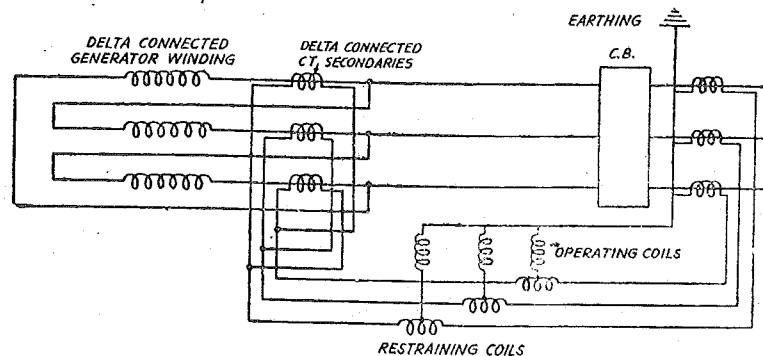

Fig. 33.3. Percentage differential relay of a delta connected generator, for phase-phase fault.

Typical protective arrangement of a generator connected to bus bars is shown in Fig. 33.4.

Differential relay provides fast protection to the stator winding against phase to phase faults and phase to ground faults. If neutral is not grounded or is grounded through impedance, additional sensitive ground fault relaying should be provided. Differential protection is recommended for generators above 2 MVA rating. Separate sets of CT's are used for each protection. Desirable features of generator differential protection are :

- high speed operation, about 15 ms. with static protection
- low setting
- full stability on external faults.

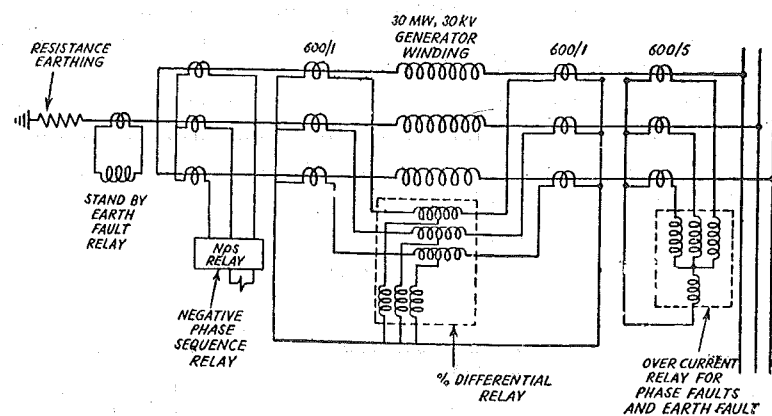

Fig. 33.4. Protection of a direct connected generator.

Differential protection which protects only generator is arranged to trip main circuit breaker and to suppress the field.

Differential protection does not respond to through faults and overloads.

Differential protection gives a complete protection to generator windings against phase to phase faults.

The biasing of the differential relay eliminates the problems associated with CT's. (Ref. Sec. 28.6).

The protection against earth faults by differential is influenced by the magnitude of earth-fault current. The magnitude of earth-fault current depends upon value of the reactance/reactance connected between neutral and earth; and the position of earth fault in generator winding. When the generator winding is earthed through impedance, a separate additional earth fault protection is necessary in addition to differential protection. The differential protection provides earth-fault protection to about 85% of generator winding.

33.4. RESTRICTED EARTH-FAULT PROTECTION BY DIFFERENTIAL SYSTEM

When neutral is solidly grounded, it is possible to protect complete alternator of transformer winding against phase to ground fault.

However, neutral is earthed through resistance to limit earth-fault currents.

With resistance earthing, it is not possible to protect complete winding from earth-fault and the % of winding protected depends on the value of neutral earthing resistor and the relay setting. While selecting the value of resistor and earth-fault relay setting, the following aspects should be kept in mind :

- The current rating of resistor, resistance value, relay setting, etc. should be selected carefully.
- Setting should be such that the protection does not operate for earth-faults on EHV side. Earth faults are not likely to occur near the neutral point due to less voltage w.r.t. earth. It is a usual practice to protect about 80 to 85% of generator winding against earth-faults. The remaining 20 to 15% winding from neutral side left unprotected by the differential protection. In addition to differential protection, a separate earth-fault protection is provided to take care of the complete winding against earth faults. (Ref. Sec. 33.6 (b)).

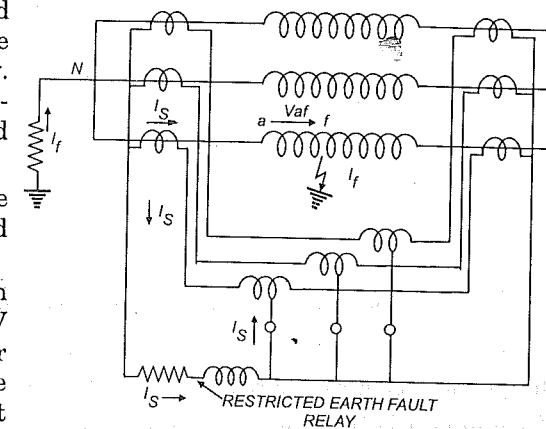

Fig. 33.5. Percentage Differential with protection Restricted Earth fault relay.

The restricted earth-fault relays in the differential protection is explained here. During earth-fault I_f in the alternator winding, the current, I_f flows through a part of the generator winding and neutral to ground circuit. The corresponding secondary current I_s flows through the operating coil and restricted earth-fault coil of the differential protection. The setting of the restricted earth fault relay can be selected independent of the setting of the overcurrent relay.

If the earth-fault I_f occurs at point f of alternator winding V_{af} is available to drive earth-fault current I_f through the neutral to ground connection. If point is nearer to terminal a (nearer to the neutral point) the forcing voltage V_{af} will be relatively less. Hence earth fault current I_f will reduce. It is not practicable to keep the relay setting too sensitive to sense the earth-fault currents of small magnitudes. Because, if too sensitive, the relay may respond during through faults of other faults due to inaccuracies of CT's, saturation of CT's etc. Hence a practice is to protect about 85% of the differential protection against earth-faults. A separate earth-fault protection covers the entire winding against earth-faults. [Sec. 33.6 (b)].

The resistance R limits the earth-fault current. If R is too small (solid earthing) earth fault currents are too large. Hence such a method is not used for large machines. Solid earthing is limited to machines upto 3.3 kV.

For low resistance earthing the resistance R is such that full load current passes through neutral, for a full line to neutral voltage.

Medium resistance earthing is commonly used on generator transformer units. The earth-fault current is restricted to about 200 A for full line to neutral voltage, for a 60 MW unit.

In high resistance earthing maximum earth-fault current is of the order of 10 A. Such earthing is used for distribution transformers and generator transformer units.

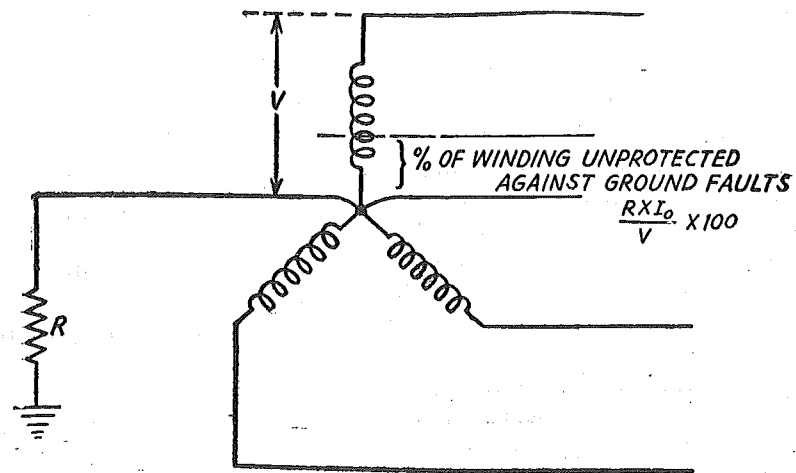

Fig. 33.6. Percentage of unprotected winding against phase to ground faults.

With higher neutral resistance, the earth faults current is reduced, hence lesser percentage of winding is protected by the restricted earth fault protection.

Assuming R is the resistance in neutral connection to the earth and the fault current for line to ground fault is equal to full load current of the generator or transformer, the value of impedance to be inserted in neutral to earth connections is given by,

$$R = \frac{V}{I}$$

where R = impedance in ohms between neutral and ground

V = line to neutral voltage

I = full load current of largest machine or transformer.

If a relay setting of 15% is chosen this affords protection of 85% of the winding of largest machine while a greater percentage of windings of smaller machines running in parallel with the large machine.

$$\% \text{ of winding unprotected} = \frac{R \times I_0 \times 100}{V}$$

R = ohmic value of impedance

I_0 = minimum operating current in primary of CT

V = line to neutral voltage.

If 15% of relay setting is used, I_0 is 15% of full load current of the machine.

Example 33.1. A generator is provided with restricted earth-fault protection. The ratings are 11 kV, 5000 kVA. The percentage of winding protected against phase to ground fault is 80%. The relay setting such that it trips for 25% out of balance. Calculate the resistance to be added in neutral to ground connection.

Solution.

$$V = \frac{11}{\sqrt{3}} \times 1000 = 6340 \text{ V}$$

$$I = \frac{5000}{\sqrt{3} \times 11} = 262 \text{ A}$$

$$I_0 = 262 \times \frac{25}{100} = 65.5 \text{ A}$$

% of winding unprotected

$$= \frac{R \times I_0}{V} \times 100$$

$$20 = \frac{R \times 65.5}{6340} \times 100$$

Hence resistance to be added in the neutral connections is

$$R = \frac{20 \times 6340}{65.5 \times 100} = 1.94 \text{ ohms. Ans.}$$

Example 33.2. The neutral point of a 10,000 V alternator is earthed through a resistance of 10 ohms, the relay is set to operate when there is an out of balance current of 1A. The CT's have a ratio of 1000/5. What percentage of the winding is protected against fault to earth and what must be minimum value of earthing resistance to give 90% protection to each phase winding?

Solution. Out of balance current in pilot wires is 1 Amp. Corresponding current in CT primary will be

$$1 \times \frac{1000}{5} = 200$$

Hence current I_0 for which the relay operates in 200 A.

% of winding unprotected

$$= \frac{R \times I_0}{V} \times 100 = \frac{10 \times 200}{\frac{10,000}{\sqrt{3}}} \times 100 = \frac{20 \times \sqrt{3}}{14} = 34.8\%$$

% of winding protected = $100 - 34.8 = 65.2\%$. Ans.

Resistance to get 90% of winding protection

$$10 = \frac{R \times 200 \times 100}{\frac{10,000}{\sqrt{3}}}$$

$$R = \frac{10 \times 10,000}{200 \times \sqrt{3} \times 100} = 2.88 \text{ ohms. Ans.}$$

In these problems, remember, for largest machine :

$$\% \text{ of winding unprotected} = \frac{R \times I_0}{V} \times 100$$

R = Resistance in neutral connection,

I_0 = Primary current for relay operation,

V = Phase voltage.

Example 33.3. A 3 phase, 2 pole, 11 kV, 10,000 kVA alternator has neutral earthed through a resistance of 7 ohms. The machine has current balance protection which operates upon out of balance current exceed 20% of full load. Determine % of winding protected against earth fault.

Solution.

$$kVA = \sqrt{3} kV I$$

$$I = \frac{10,000}{\sqrt{3} \times 11} = 525 \text{ A.}$$

Out of balance current for which relay operates I_0

$$= \frac{20}{100} \times 525 = 105 \text{ A}$$

Voltage V line to neutral = $\frac{11}{\sqrt{3}} = 6.35 \text{ kV}$

% of winding unprotected against earth fault

$$= \frac{R \times I_0}{V} \times 100 = \frac{7 \times 105 \times 100}{6.35 \times 1000} = 11.6\%.$$

Note : % reactance of generator winding was not considered.

Example 33.4. Fig 33.7 shows percentage differential relay applied to the protection of an alternator winding. The Relay has a 1% slope of characteristic $I_1 - I_2$ vs. $(I_1 + I_2)/2$.

A high resistance ground fault occurred near the grounded neutral end of the generator winding while generator is carrying load. As a consequence, the currents in amperes flowing at each end of the winding are shown in Fig. 33.7. Assuming CT ratio of 400/5 amperes will the relay operate the trip of the breaker.

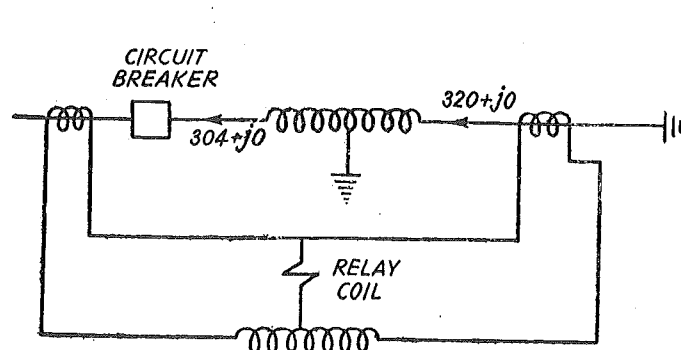

Fig. 33.7 (a)

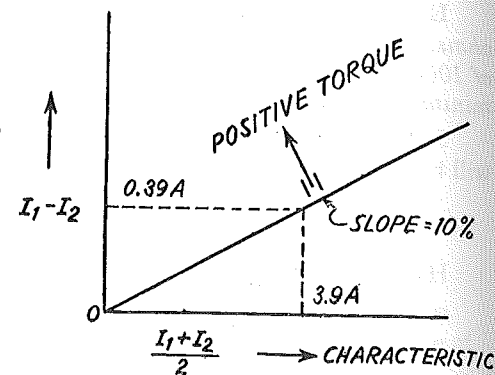

Fig. 33.7 (b)

Solution. CT ratio 400 : 5

Secondary current of CT₁

$$I_1 = \frac{304 + j0}{400} \times 5 = 3.8 + j0 \text{ A}$$

Secondary current of CT₂

$$I_2 = \frac{320 \times 5}{400} = 4 + j0 \text{ A}$$

Directions of current are as shown in Fig. 33.8.

Out of balance current $I_1 - I_2$ flows through the relay coil. i.e.

$$3.8 - 4.0 = -0.2 \text{ A}$$

$$\frac{I_1 + I_2}{2} = \frac{3.8 + 4}{2} = 3.9 \text{ A.}$$

Corresponding point on $I_1 - I_2$ vs. $\frac{I_1 + I_2}{2}$ characteristic is 0.39 A [from the known slope]. The relay operates if out of balance current is above the characteristic. In this problem out of balance current is 0.2 A and therefore in negative torque region. Hence the relay does not operate. **Ans.**

Examples 33.5. A 11 kV, 3 phase Alternator has full load rated current of 200 A. Reactance of armature winding is 15 per cent. The differential protection system is set to operate on earth fault currents of more than 200 A. Find the neutral earthing resistance, which gives earth fault protection to 90% of stator winding.

Solution. In this problem, the alternator reactance should be considered in calculations.

Full load current 200 A.

Let resistance in neutral connection be r ohms. Let reactance per phase be X ohms.

$$\frac{IX}{V} \times 100 = \%X \quad \begin{cases} I = \text{rated current} \\ X = \text{reactance per phase in ohms} \\ V = \text{phase voltage.} \end{cases}$$

$$\frac{200 \times X}{11/\sqrt{3} \times 100} \times 100 = 15$$

$$X = \frac{15 \times 11 \sqrt{3}}{20} = 4.75 \text{ [ohms]}$$

Reactance of unprotected winding = $4.75 \times 0.1 = 0.475$ [ohms]

Voltage induced in 10% unprotected winding

$$= \frac{11000}{\sqrt{3}} \times 0.1 = 635 \text{ volts.}$$

If the voltage is say v and impedance is say Z , then fault current in the loop is $i = v/Z$

$$Z = \sqrt{r^2 + x^2}$$

where r = resistance in neutral connection

x = reactance of 10% winding

v = voltage of 10% winding

Given $i = 200$ A

$v = 635$ (calculated value)

$x = 0.475$ (calculated above)

$$200 = \frac{635}{\sqrt{r^2 + (0.475)^2}}$$

$$r^2 + (0.475)^2 = (3.18)^2 = 10.2$$

$$r = 3.145 \text{ ohms. Ans.}$$

Or

Neglecting the impedance of alternator winding, % of unprotected winding

$$= \frac{R \times I_0 \times 100}{V}$$

where R = resistance in neutral circuit

I_0 = minimum operating current in generator winding.

V = line to neutral voltage.

In this problem : R is to be determined

$$V = \frac{11,000}{\sqrt{3}} = 6350 \text{ V}$$

$$I_0 = 200 \text{ A}$$

% of unprotected winding = $100 - 90 = 10$

Hence

$$10 = \frac{R \times 200 \times 100}{6350}$$

$$R = \frac{63,500}{20,000} = 3.175 \text{ ohms.}$$

Hence resistance in neutral connection = 3.175 ohms.

33.5. OVERCURRENT AND EARTH-FAULT PROTECTION FOR GENERATOR BACK-UP

For generators above 1 MW, where primary protection to stator winding is provided by Differential Protection, the overcurrent and earth-fault protection gives back-up protection for external phase to phase faults and earth-faults (Ref. Fig. 33.9).

Induction type inverse definite minimum time relays may be used for generator back-up protection for external faults.

Since the faults in stator winding are fed by the stator winding itself, their influence on current in the outgoing terminals of generator depends upon fault level of the main bus (Ref. Fig. 33.10).

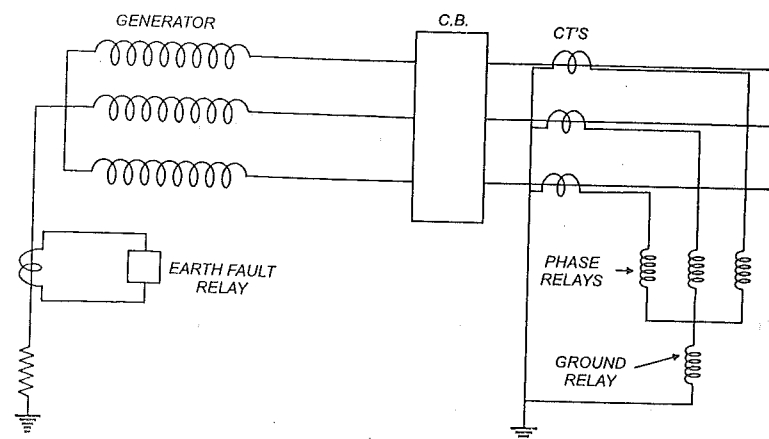
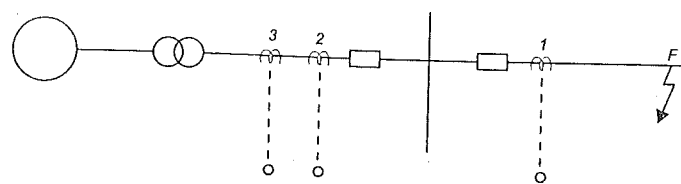

Fig. 33.9. Back-up protection by overcurrent protection.



Sequence of operation = 1, 2, 3

1. Line protection.
2. Bus bar protection.
3. The generator back-up overcurrent, earth-fault protection.

Fig. 33.10. The generator back-up protection should be the last to operate for external faults.

Hence overcurrent and earth-fault relays *do not* provide satisfactory protection against internal faults.

However the overcurrent and earth-fault relays provide back-up protection to generator against external faults (e.g. faults in bus zone, transmission zone).

The setting is selected that the generator overcurrent and earth-fault protection *does not* normally operate for external faults such as *F*.

However, if fault *F* continues for a long time due to failure of line protection (1), the fault will be fed by the generator. Hence the over-current and earth-fault protection of generator (3) may be set to operate with due time lag for higher values of external fault currents. Hence high set, definite minimum time, induction type, inverse over-current, earth fault relays are recommended for generator back-up.

33.6. (a) SENSITIVE STATOR EARTH-FAULT PROTECTION

When generator neutral is earthed through a high impedance, differential protection does not protect the complete alternator stator winding against earth faults, hence a separate sensitive earth-faults protection is necessary. The method for sensitive earth-fault protection depends upon the generator connection.

Two alternative methods are employed for neutral connection.

- The neutral connected through resistor which limits the maximum earth-fault current to much lower value than full load current, Fig. 33.11 (a). This method is preferred for large units.
- The neutral connected through a voltage transformer. The earth-fault current is limited to the magnetising current of the voltage transformer plus the zero-sequence current of generator, Fig. 33.11 (b).

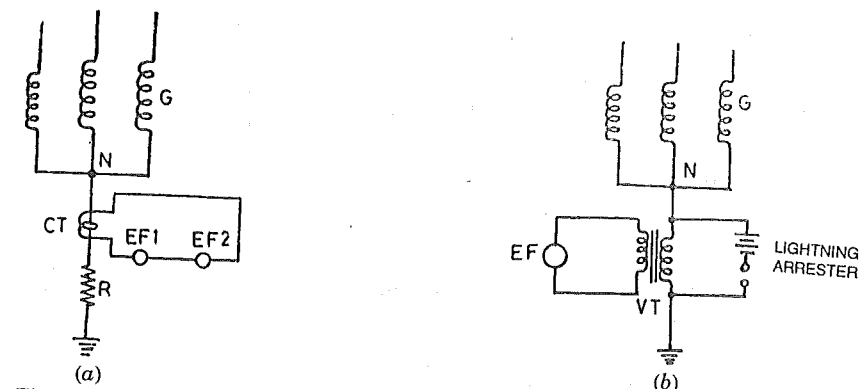

Fig. 33.11. Sensitive earth-fault protection of generator-transformer unit.

With resistance earthing (Fig. 33.11) two earth-fault relays may be provided on the secondary side of neutral CT. The First EF relay is set at 10 per cent and is instantaneous type. The second EF relay is inverse definite minimum time (IDMT) and is set at 5 per cent. (The relay pick-up when earth fault current is 5 per cent of full load current of generator).

Depending upon sensitivity, the first relay would protect about 90 per cent of stator winding and the second winding about 95 per cent. For such sensitive settings, it is necessary to provide a time delay, otherwise the relays may respond to transient neutral currents during external faults.

When neutral is connected through VT (Fig. 33.11), the rated primary voltage of VT is generally equal to phase to neutral voltage of generator. The EF relay is connected to the secondary of VT with a setting of 10% of rated secondary voltage of VT. When the voltage between neutral and earth reaches 10% of phase to neutral voltage of generator, the earth-fault relay operates.

The VT for neutral connection is specially designed. It should not saturate for twice the maximum neutral to earth voltage. The VT is protected from high voltage surges by Lightning Arrester connected in parallel with the primary. (Fig. 33.11(b)).

33.6. (b) 100% STATOR EARTH-FAULT PROTECTION

The earth-fault protection by differential relays or by residually connected relay can give effective protection to about 80 to 85% of generator winding. 100% stator earth-fault protection is provided in recent installations.

A coupling transformer is connected in neutral to ground circuit. A coded signal current is continuously injected into stator winding through the coupling transformer. The frequency of coded signal is 12.5 Hz. During normal condition the signal fed into stator winding flows only into stray capacitance of generator and directly connected system. In case of earth-fault, the capacitance is by-passed and the monitoring current increases. The increase in monitoring current (of 12.5 Hz) is sensed by the measuring system.

This protection covers 5 to 20% of stator winding from the neutral end. The remaining 80% winding is protected by differential protection or earth fault protection discussed in Sec. 33.6 (a).

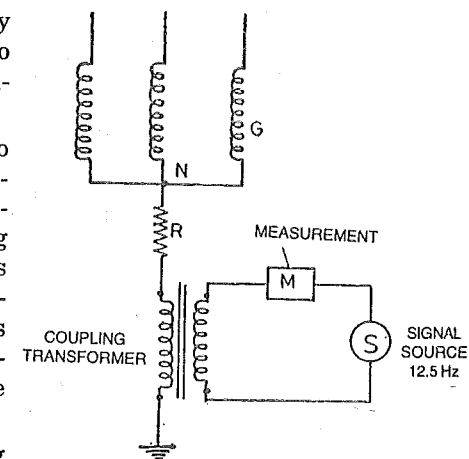

Fig. 33.11. 100% Stator earth fault protection by signals through neutral.

33.7. PROTECTION AGAINST TURN-TO-TURN FAULT ON STATOR WINDING

The incidence of turn to turn fault in alternator is rare. One method of detecting inter-turn faults is by employing five limb voltage transformer with tertiary connected to watt hour meter type induction relay. The inter-turn faults are detected by measuring the residual voltage of gen-

erator terminals. This voltage appears across the tertiary winding which is connected to operating winding of a three element directional relay. The quadratic winding is operated from secondary side of the voltage transformer (Fig. 33.12).

During normal condition, the residual voltage is zero, i.e.,

$$V_{RES} = V_{RN} + V_{YN} + V_{BN} = 0.$$

This balance is disturbed during inter-turn fault on any of the single windings. And the residual voltage is fed to the relay coil.

When the generator is with single winding per phase, the Residual Voltage Detection method is employed for inter-turn fault protection.

Another method is to connect main voltage transformers in star-delta and connect an auxiliary VT in the delta circuit (Fig. 33.13). A voltage V_{res} proportional to the residual voltage

$$V_{RES} = V_{RN} + V_{YN} + V_{BN}$$

flow through the secondary delta connected winding of the VT. The relay is connected in this circuit via an auxiliary VT. The short circuit between turns gives residual voltage of fundamental frequency

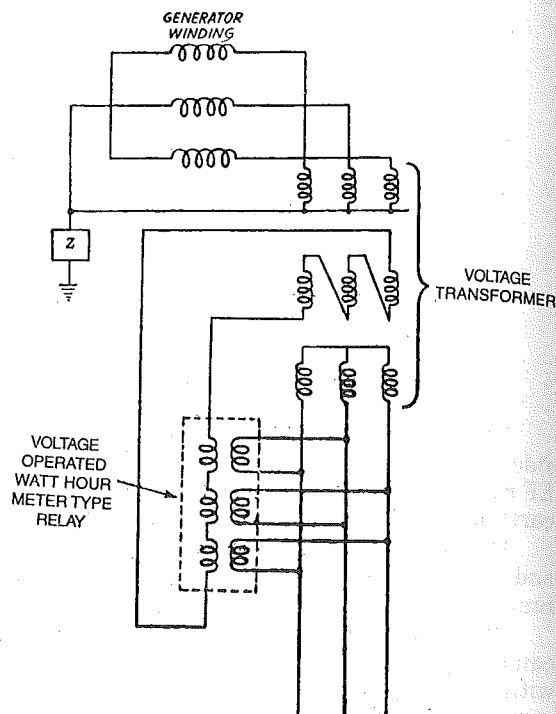

Fig. 33.12. Generator protection against inter-turn faults by residual voltage direction.

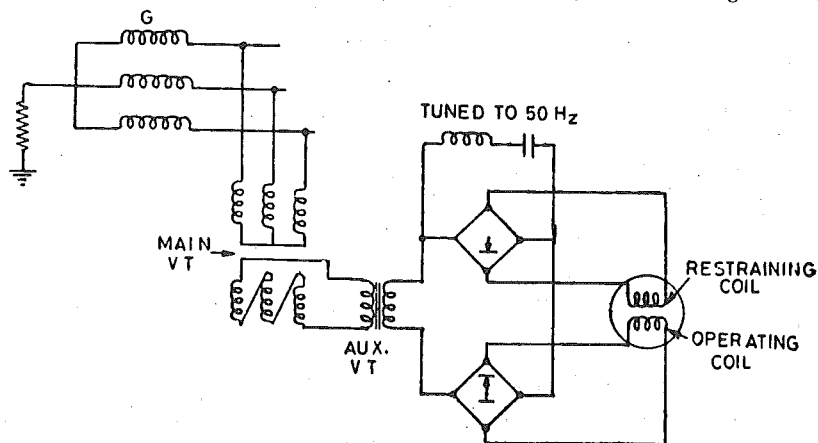

Fig. 33.13. Residual voltage inter-turn fault protection using main VT.

which should operate the relay. The relay should not operate for earth fault. Earth fault also causes residual voltage. Hence the zero-sequence voltages of third harmonic are fed to the restraining coil of the relay. The LC circuit tuned to fundamental frequency offers low resistance path to power frequency voltages appearing due to inter-turn faults. Hence for inter-turn faults the restraining current does not flow and relay operates only for inter-turn fault.

Another method of inter-turn fault protection is based on cross-differential principal (Fig. 33.14). In this case, the stator winding has two separate parallel paths. The current transformer primaries are inserted in these paths and the secondaries are cross-connected. During inter-turn fault in the phase winding, the out-of balance current CT secondaries flows through the relay. Such a protection can be extremely sensitive. However it can be employed to generators with parallel winding for each phase. (Ref. Fig. 33.14).

The fault between turns does not disturb the current balance of CT's for differential protection, hence differential protection does not detect inter-turn fault.

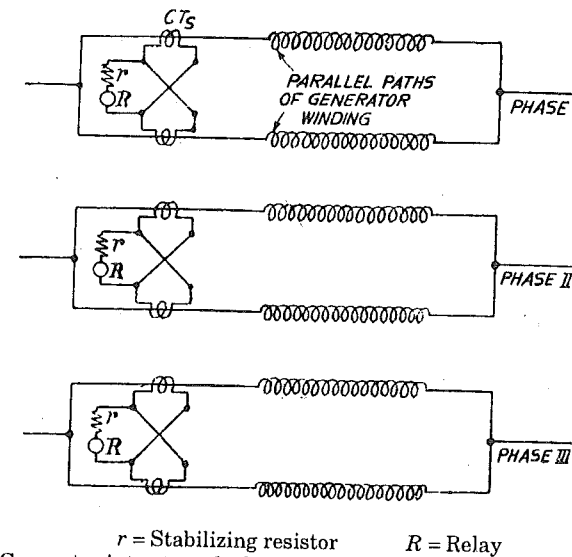

Fig. 33.14. Generator inter-turn fault protection based on cross-differential principle.

33.8. ROTOR EARTH FAULT PROTECTION

A single ground fault does not cause flow of current since the rotor circuit is ungrounded. When the second ground fault occurs part of the rotor winding is by-passed and the currents in the remaining portion may increase. This causes unbalance in rotor and may cause mechanical as well as thermal stresses resulting in damage to the rotor. In some cases the vibrations have caused damage to bearings and bending of rotor shaft. Such failures have caused extensive damage.

One method of detecting earth fault on rotor circuit is described below. A high resistance is connected across the rotor circuit. The centre point of this is connected to earth through a sensitive relay. The relay detects the earth faults for most of the rotor circuit (Fig. 23.15) except the centre point of rotor.

Other methods of rotor earth fault protection include d.c. injection method and a.c. injection method, (Fig. 33.16). A single earth fault in the rotor circuit completes the circuit comprising voltage source S, sensitive relay earth fault. Thereby the earth fault is sensed by the voltage relay. D.C. injection method is simple and has no problems of leakage currents.

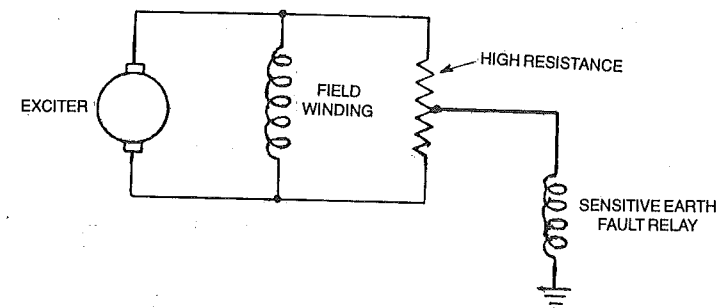

Fig. 33.15. Schematic diagram of rotor e.f. protection.

33.9. ROTOR TEMPERATURE ALARM

This protection is employed only to large sets and indicates the level of temperature and not the actual hot spot temperature. It is not practicable to embed thermocouples in rotor winding since the slip ring connections would be complicated. Resistance measurement is adopted. The rotor voltage and current are compared by a moving coil relay. The voltage coil of the relay is connected across the slip ring brushes. The current coil is connected across the shunt in the field circuit. Double actuating quantity moving coil relay is used, the restraining coil being circuit coil and the operating coil is the voltage coil (Fig. 33.17). Resistance increases with temperature.

The relay measures the ratio

$$V/I = R \text{ (which gives a measure of rotor temperature).}$$

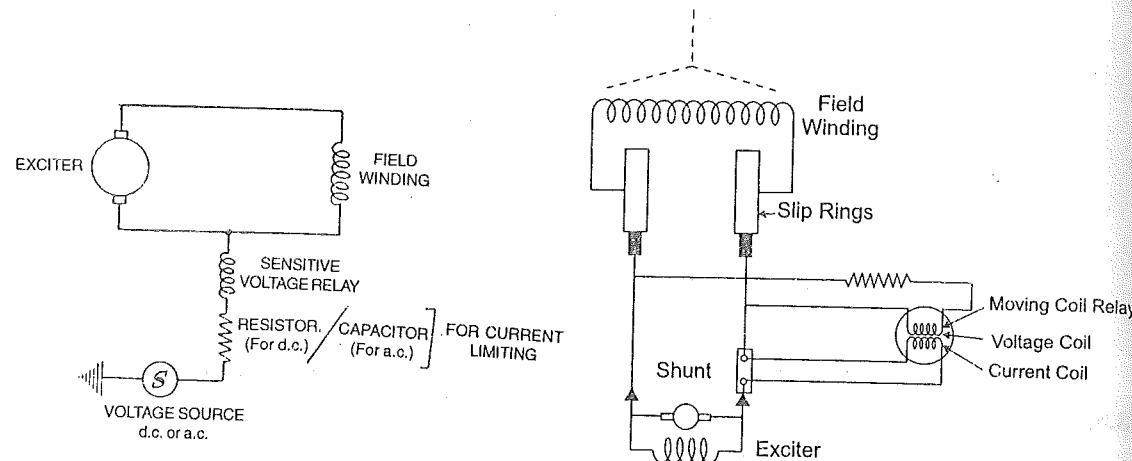

Fig. 33.16. Principle of d.c./a.c. injection method for rotor earth fault protection.

Fig. 33.17. Rotor temperature protection by measuring V/I .

33.10. NEGATIVE SEQUENCE PROTECTION OF GENERATORS AGAINST UNBALANCED LOADS

The unbalanced 3-phase stator currents cause double frequency currents to be induced in rotor. They cause heating of rotor and damage the rotor. Unbalanced stator currents also cause severe vibrations and heating of stator. From the theory of symmetrical components, we know that unbalanced three-phase currents have a negative sequence components. This component rotates at synchronous speed in a direction opposite to the direction of rotation of rotor. Therefore double frequency currents are induced in the rotor.

Negative sequence current filter with overcurrent relay provides protection against unbalanced loads (Fig. 33.18).

The relative asymmetry of a three-phase generator is defined as the ratio of negative sequence current (I_2) to rated current (I_n); i.e.,

$$\%S = \frac{I_2}{I_n} \times 100$$

In case of loss of one phase the relative asymmetry $\%S$ is equal to 58%.

The time for which the machine can be allowed to operate for various amounts of relative asymmetries depends on type of machine. The additional heat caused by negative sequence currents in rotor is proportional to $I_2^2 t$. The product $I_2^2 t$ is a machine characteristic.

$I_2^2 t = 30$ is a generally accepted figure as per ASA, (I_2 in per unit, t in sec.) for would rotor machines and 40 for salient pole machine.

It is generally necessary to install negative sequence relays that match with the $I_2^2 t$ characteristic of the machine. (Ref. Fig. 33.18 (b)).

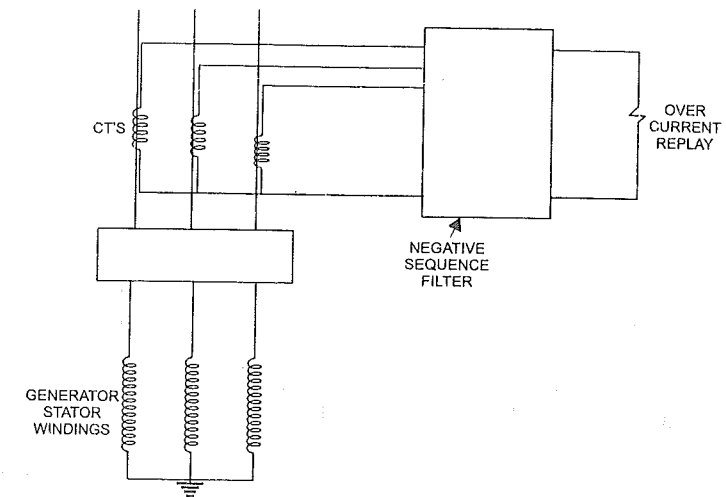

Fig. 33.18. (a) Protection against unbalanced load using negative sequence filter.

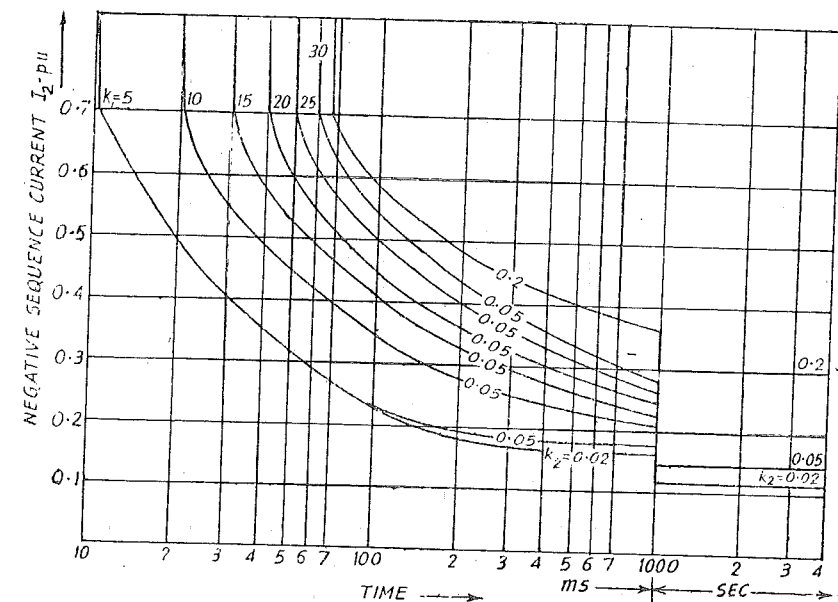

Fig. 33.18. (b) Current time characteristics of a static negative phase sequence relay. Courtesy: Brown Boveri, Switzerland.

Negative sequence filter circuit comprises resistors and inductors connected in the secondary circuit in such a way that negative sequence component flows through the relay coil, Z_L (Ref. Fig. 33.19).

The overcurrent relay (Z_L) of negative phase sequence protection is with inverse characteristics matching with the $I_2^2 t$ rating curve of the machine and is arranged to trip the unit.

33.11. NEGATIVE PHASE SEQUENCE CIRCUIT

Fig. 33.19 illustrates the principle of the negative phase sequence circuit. The twin windings of the two auxiliary current-transformers are so connected to the line current-transformers that under normal balanced-load condition, currents I_a , I_b and I_c flow in the direction shown. Impedance

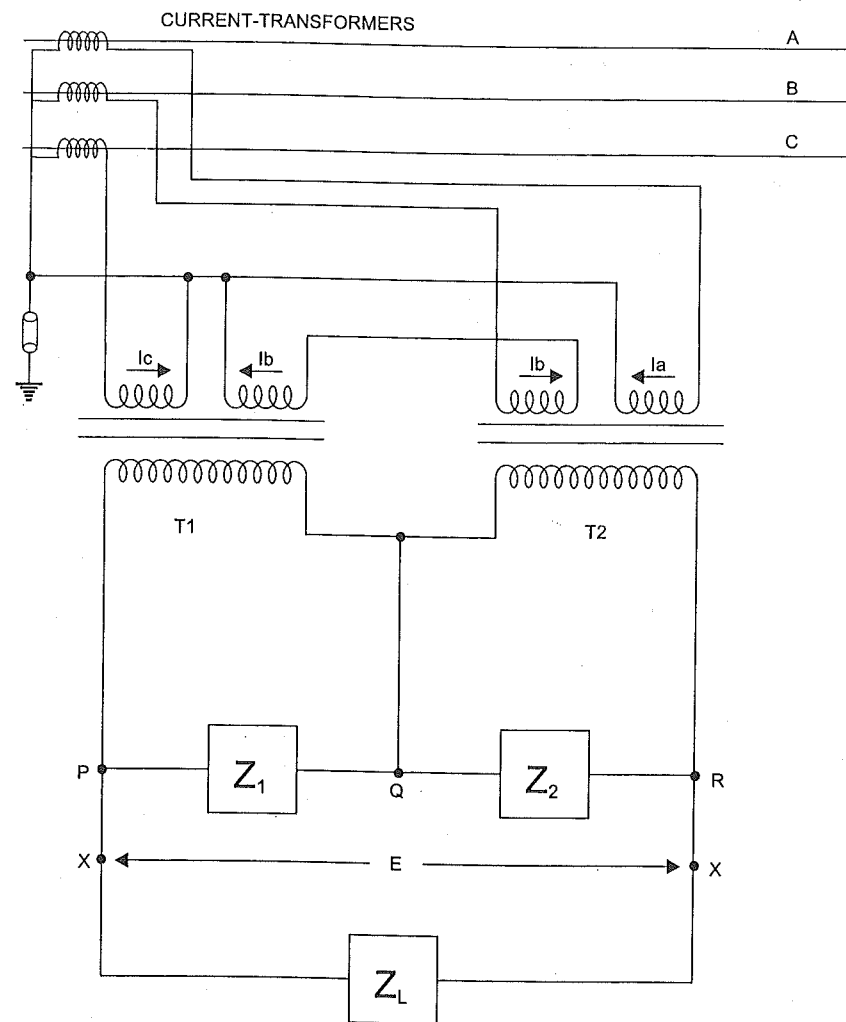

Fig. 33.19. Circuit showing principle of negative phase-sequence circuit.
Courtesy. Reyrolle Parsons Ltd. England.

Z_1 and Z_2 are connected across auxiliary current-transformers T_1 and T_2 , and a load impedance Z_L is connected across the terminals XX .

When primary load current flows, the current through T_1 will be $(I_b - I_c)$ and that through T_2 will be $(I_a - I_b)$. For a given value of load impedance Z_L , (over-current relay) the impedances Z_1 and Z_2 are chosen such that points P and R remain at the same potential, i.e., the voltages across QR and QP are equal and opposite. Under unbalanced conditions these voltages differ, and an output is produced proportional to the negative-phase sequence across XX (voltage E) so as to operate the relay. The protection remains stable on symmetrical overloads up to about three times rated full load.

As the output is instantaneous in operation, it is necessary to operate the equipment in conjunction with a time-lag relay.

Negative phase sequence relays are used for protection against unbalanced loads.

33.12. STATOR-HEATING PROTECTION

Generator overheating can be caused by failure cooling system or by sustained overloads.

Embedded resistance detectors or thermocouples are provided in the slots among with the stator coils for large generators. These give an alarm if temperature rises above safe value. The protection is provided for generators above 1 MW.

It is not practicable to provide overload protection by back-up stator-fault over-current protection. Because back-up over-current protection is generally set for sensing fault currents and should not trip for overloads. Electrical over-current relays cannot sense the winding temperature accurately because temperature rise depends on I^2Rt and also on cooling. Electrical protection cannot detect a cooling system failure.

33.13. LOSS OF FIELD PROTECTION

A 'loss of field' or 'field failure' can be caused by opening of field switch or field circuit-breaker. The behaviour of the generator depends upon whether the generator connected singly to a load or whether the generator is connected in parallel with other units or the system.

If it is a single unit supplying a local load, the loss of field causes loss of terminal voltage and subsequently loss of synchronism depending upon the load conditions.

If the generator is connected in parallel with other units it can draw the magnetizing currents from the bus-bars and continue to run as induction generator. The magnetising currents are large and are to be supplied by other units. Hence the stability of the other units is affected.

The power-output of the generator is reduced while running as induction generator. The slip frequency e.m.f. is induced in the rotor.

In wound rotor generators, the e.m.f. induced in the rotor gives rise to circulating currents in the rotor body and slot wedges resulting in overheating. In salient pole machines there are no rotor slots and the rotor body is formed of laminations. Hence salient pole machines can endure the condition for a longer duration.

The stator currents may increase above normal current rating of generator during the run as induction generator. High currents may cause voltage drop and overheating of generator bus-bars, stator winding, etc.

Fig. 33.20 illustrating the loss of field protection by means of an under-current relay connected across a shunt in series with the field winding.

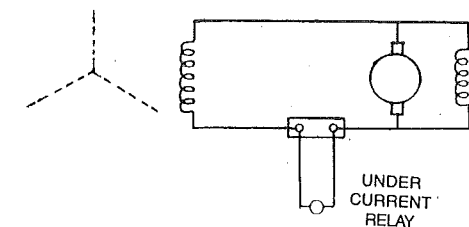

Fig. 33.20. Loss of field protection.

33.14. REVERSE POWER PROTECTION (Ref. Sec. 26.16 Directional Power Relay)

When the input to the turbine is stopped the generator continues to rotate as a synchronous motor, taking power from the bus bars. It then rotates as synchronous motor and the turbine acts as a load. Such incidents have occurred in old stations.

Motoring protection is mainly for the benefit of the prime-mover, and load coming on generator bus while motoring. Reverse power protection measures the power flow from bus-bars to the generator running as a motor. Normally the power taken in most cases is low of the order of 2 to 10% of the rated power. Power factor and current depends on excitation level.

During the motoring action of the generator, the power flows from the bus-bars to the machine and the conditions in the three phases are balanced. Hence a single-element directional power relay (reverse power relay, Sec. 26.6 sensing the direction of power flow in any one phase is sufficient. The CT's for reverse-power protection may be either at the neutral end or the bus-bar and of the generator winding. The setting depends on the type of prime-mover. Intentional time lag is provided

in the reverse power protection so that the protection does not operate during system disturbances and power swings.

1. **Steam Turbine.** Time delay sensitive directional relays, set to operate on somewhat less than 3% of rated power.

Back-pressure steam turbine sets should be protected with sensitive reverse power protection. The blades of such steam turbine get overheated quickly as the stem gets trapped if rotated in opposite direction due to windage.

In steam turbines the steam acts like a coolant of the turbine blades and maintain them at constant temperature. If the steam flow stops, the blades get overheated due to windage (friction with air).

In condensing type steam turbine, the heating of blades is slower hence reverse power protection may not be necessary.

For large turbo-generators with back-pressure type, non-condensing steam turbines, sensitive reverse power protection with sensitivity of the order of 0.5% of rated power is preferred. The relay should have directional stability for the entire relay operating zone (Fig. 33.21).

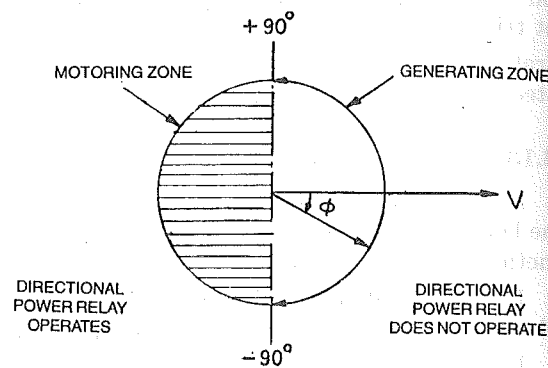

Fig. 33.21. Operating characteristics of reverse power protection.

2. **Reciprocating Engine.** Motoring is harmful to the engine. Hence the reverse power protection should be sensitive and the engine must be disconnected from generator shaft during motoring.

3. **Hydraulic Turbines.** The water-turbine is generally fitted with mechanical devices which detect the low water flow because such a flow causes cavitation. However reverse power protection may be provided to operate for motoring power less than 3 per cent of rated power.

4. **Gas Turbine.** The gas turbine driven generator should not be permitted to operate as a motor because the gas turbine offers a load of 10 to 50% of full load during motoring.

The factors to be considered are :

1. Capability of prime-mover to run as a load.
2. Load current drawn while motoring.

The reverse power protection is generally set for 10% rated power in reverse direction.

33.15. OVER-SPEED PROTECTION

It is essential to incorporate safety device in turbine governing system to prevent overspeeding.

Overspeeding can occur due to sudden loss of electrical load on generator due to tripping of generator circuit-breaker, before disconnection of prime-mover.

The speed of the generator should be maintained by the governor.

The overspeeding results in over voltages and increase in frequency.

Hydro-generators.* Overspeeds are prevented by centrifugal governors. Sensitive frequency relays operated from an auxiliary permanent magnet alternator fitted on the shaft sense the over-speed.

Steam turbines.* The generator responds to the over-speed caused by load rejection. However, the steam beyond governor keeps on expending causing further increase in speed. The steam beyond governor should be bypassed by some other path quickly so that input to steam turbine is bypassed

* Blades of steam turbine have tendency to vibrate at speeds other than rated speed. Frequency Relays are used. Ref. Sec. 45.8.1.

quickly and increase in speed is checked. This is achieved by sensing overspeeding by electrical measurements on generator side and by steam measurement on turbine side.

The emergency valve is closed momentarily so as to stop the steam supply more rapidly. The valve opens again automatically, meanwhile the governor responds to changed conditions and regulates the speed.

With gradual reduction in load the emergency valve does not operate.

33.16. FIELD SUPPRESSION

When a fault develops in an alternator winding even though the generator circuit-breaker is tripped, the fault continues to be fed because e.m.f. is induced in the generator itself. Hence the field circuit-breaker is opened and the stored energy in the field winding is discharged through another resistor. This method is known as field suppression.

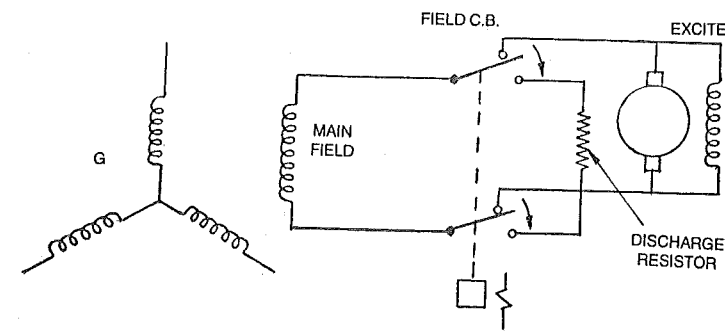

Fig. 33.22. Principle of field suppression (The energy in main field is discharged through resistor by closing C.B. on to the discharge resistor).

33.17. OTHER PROTECTIONS

Bearing Insulation. In case of large generators, the voltage generated in the shaft due to leakage fluxes can circulate currents through the shaft. These currents flow through the bearings and foundation and cause pitting of bearing. To prevent the circulating shaft currents one of the bearings and its auxiliary piping should be insulated from ground.

Vibration Protection. A vibration detector may be mounted on one of the bearing pedestals in the case of a horizontal shaft machine, or on the upper guide-bearing of a vertical shaft machine. It may be set to trip the machine or initiate an alarm when the radial deflections of a certain duration exceed a pre-selected value. Stepped Underfrequency Relays are also used. (Ref. Ch. 45)

Bearing overheating protection. Temperature detectors are inserted in the bearings which are connected to temperature indicator and alarm circuits.

Mechanical conditions. These are related with prime mover, cooling systems and other auxiliaries. Sometimes these abnormal conditions are serious enough to bring about the complete shut-down. But generally an alarm is provided for less serious abnormal conditions.

Loss of vacuum. Failure of vacuum plant associated with steam turbine gives rise to very high temperature and pressure at exhaust end. The loss of vacuum protection is in two stages :

- In the first stage, the unloading gear operates and the control valves start to close the input to steam turbine. If loss of vacuum is a temporary, the valve opens again and original condition is restored.
- The second stage operates when the vacuum is too low, the vacuum trip operates the emergency control and the generator unit is tripped open.

33.18. PROTECTION OF SMALL, STANDBY GENERATORS*

Small generators and standby generators require simple but reliable protective equipment. Basically the following operating conditions and fault conditions should be considered while selecting a protection scheme. (Also, refer Sec. 43.9).

Overcurrent. The generator of the standby set and the consumers must be protected against the effects of short circuit currents. Fuses are inaccurate in their rupturing characteristics and are not available for high currents. Also, the rupturing of a fuse cannot be indicated at a central display. It is advisable therefore, to use a time-lag over-current relay operating direct on the generator breaker, even at relatively modest overcurrents.

Overvoltage. Dangerous overvoltages, such as can occur due to a fault at the controller or due to sudden load shedding can be monitored with a time-lag overvoltage relay.

Overload. The winding insulation of an electrical machine can sustain damage at excessive bar temperatures and this will shorten its service life. Stator winding temperatures must therefore be monitored. If a given permissible limit is exceeded, an alarm must be given or the machine switched off. Monitoring is mostly carried out by a thermal replica of the machine; a thermal relay. (Ref. Sec. 31.6).

Frequency. Certain installations, such as transmitters, depend on a constant frequency and consequently the frequency must be monitored. If there is an excessive drop in frequency the generator breaker of the standby set must be opened or an alarm given. If the relay acts on the generator breaker there is no need to throttle-back the diesel engine.

In other cases the frequency relay prevents feedback into the supply system. During storms or under other conditions which can be dangerous as far as the supply system is concerned, the standby set is often run in the parallel with the system before being separated. If, under these conditions, the supply voltage fails, relay must respond to the drop in frequency due to the overloading of the machine and cause the line switch to open; the standby set thus continues to operate without interruption.

Depending on the plant and the design of the protection system, it may be necessary to use two frequency relays with staggered time gradings, arranged such that the first one opens the line switch and the second opens the generator breaker. In many cases, however, the trip command of only one of the relays is passed from the control system to one or the other breaker. In parallel operation with the system the frequency relay operates on the line switch, and in isolated operation on the generator breaker. To give the standby generator drive time to accelerate again after disconnection from the supply, the command to the generator breaker must be delayed.

Forward power. The rated power output of a standby generator set is adequate to cover the total installed power of the installation. To this end a part of the load, which is classified according to certain priorities for this purpose, is switched off during standby operation. This can be carried out the control system or by a power relay with several load-shedding stages.

A power directional relay can be used in place of the frequency relay to prevent feedback from the standby set into the system. As soon as the maximum power feedback permissible in normal service is exceeded, the relay issues a trip command to the line switch.

Reverse power. If the drive for the generator fails in parallel operation, the generator is driven by the system and operates as a motor. To prevent damage to the machine a power directional relay must be used to monitor the direction of the active power flow. Under such conditions the generator must be decoupled from the system as quickly as possible. The shortest response time depends on the degree of hunting to be expected in the system.

* Acknowledgements to Brown Boveri and Co. Ltd., Switzerland Ref. "Protection Equipment for Stand by Generating Plant and Small Generators".

Table 33.4.
Protection Chart for Generator-Transformer Unit (Ref. Table 33.2)

	<i>Protection</i>	<i>Equipment covered</i>
1.	Generator differential protection.	Generator
2.	Main transformer differential protection.	Main transformer
3.	Unit auxiliary transformer differential protection.	Unit auxiliary transformer
4.	Overall differential protection.	Generator main transformer
5.	Generator protection.	Ref. Table 33.1
6.	Unit auxiliary transformer protections.	Ref. Table 32.1, 32.2
7.	Main transformer protection.	Ref. Table 32.1, 32.2

33.19. Generator Transformer Unit Protection

The scheme of Generator transformer Unit Protection comprises the following (Ref. Table 33.2).

- Primary Protection and back-up protection of generator
- Primary and back-up protection of main transformer
- Primary and back-up protection of unit auxiliary transformer (service transformer)
- Combined protection for generator and main transformer. The basic layout of generator connections has been illustrated in Fig. 33.1.

33.19.1. COMBINED DIFFERENTIAL PROTECTION FOR GENERATOR MAIN TRANSFORMER

In the protection scheme the differential protection generally covers the generator and main step-up transformer. Separate differential protections are provided for generator and for unit auxiliary transformers (Ref. Table 33.4).

The zone of combined differential protection may include generator stator winding, main step-up transformer and the bus-bar connections. A separate set of CT's is provided for this protection. The CT's at neutral side are star connected and CT's on HT side of main step-up transformer are delta connected. A third set of CT's is provided on the Teed-off to unit-auxiliary transformer. The CT's on Teed-off connection are necessary to compensate for the load current in Teed-off connection. These CT's are connected in parallel with the CT's of combined differential protection (Fig. 33.23).

Generally it is not practicable to cover the unit auxiliary transformer in the generator main transformer differential protection due to following reasons :

- Zone of protection should not be too large.
- Burden on CT's increases.
- Rating of unit auxiliary transformer is 1/10th main generator and it is difficult to select relay setting.

33.20. STATIC PROTECTION OF LARGE TURBOGENERATORS AND MAIN TRANSFORMER

The static protection equipment for protecting generator-comprises solid state relays in form of plug in assemblies, associated auxiliaries, intermediate transformers, tripping programmes and testing facilities for circuits. As compared with conventional electrons mechanical relays, the static protection has many superior features which make the use of static relays, a must. The reasons being :

- Complex generator protection requirements.

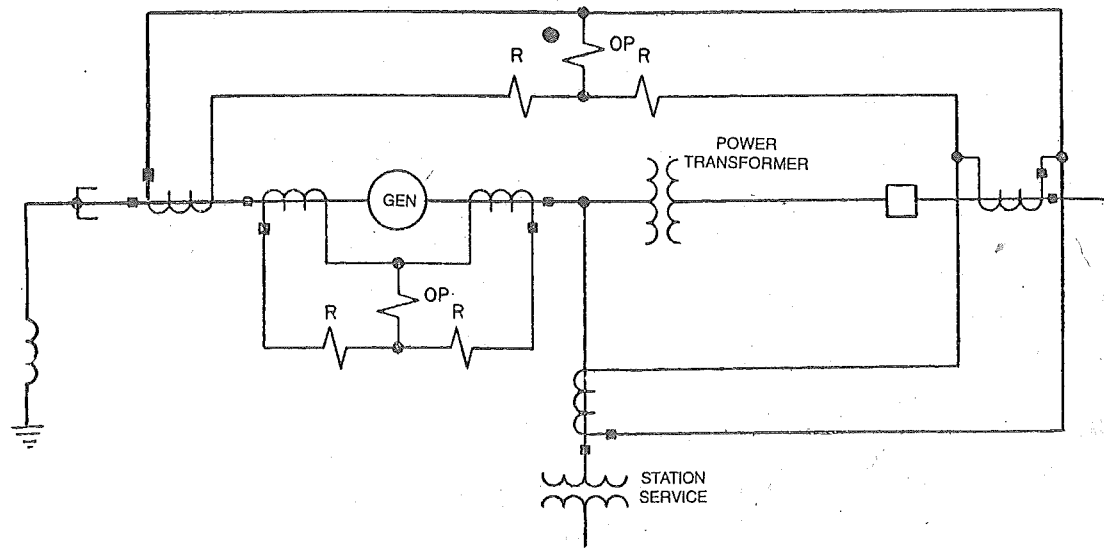

Fig. 33.23. Differential Protection of unit type Generator-Transformer systems. (Single line diagram)
(Courtesy : Westinghouse Electric Corporation, U.S.A.)

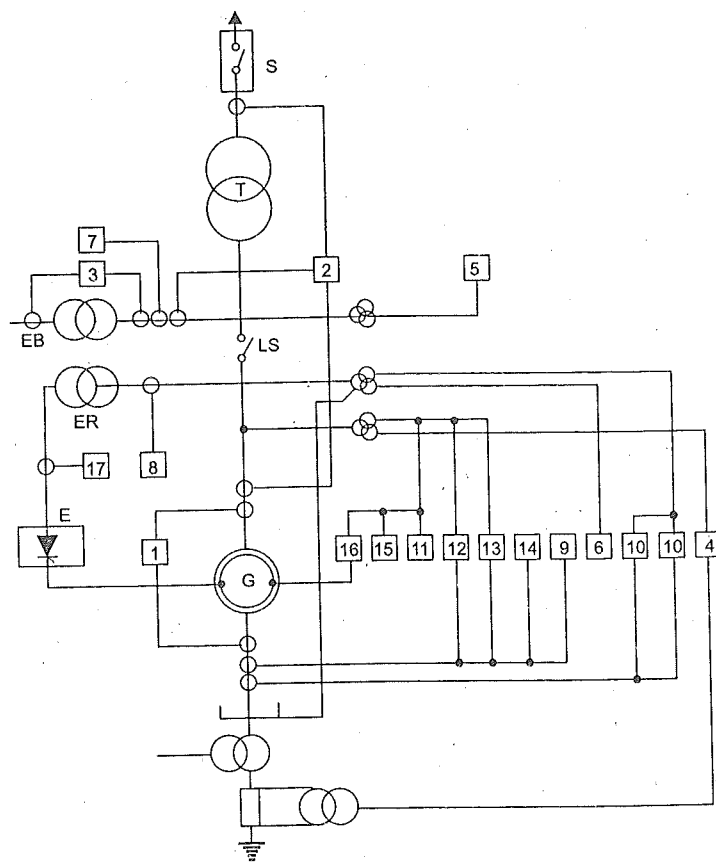

Fig. 33.24. Protection scheme for a large generator in unit connection
(*Courtesy : Brown Boveri, Switzerland)

- R = Restraining Coil
- O = Operating coil.
- G — Generator Unit transformer
- EB — Service transformer
- T — Unit transformer
- ER — Exciter transformer
- S — Circuit breaker
- E — Excitation system
- LS — Load switch ; (which can switch normal load currents)

- Relay :
- 1 — Differential protection
 - 2 — Differential protection, unit transformer generator,
 - 3 — Differential protection, service transformer
 - 4 — Stator earth-fault protection
 - 5 — Earth-fault protection
 - 6 — Inter-turn-fault protection
 - 7 — Overcurrent protection, service transformer
 - 8 — Overcurrents protection exciter transformer
 - 9 — Stator overload protection
 - 10 — Reverse power protection (duplicated)
 - 11 — Overvoltage protection
 - 12 — Minimum impedance or maximum current/minimum voltage back-up protection
 - 13 — Asynchronous running protection
 - 14 — Asymmetrical load protection
 - 15 — Minimum frequency protection
 - 16 — Rotor earth-fault protection
 - 17 — Rotor overload protection

- large number of protective systems resulting in large CT burdens and complex set-up.
- CT saturation problems.
- stability requirements of protective relaying.
- large power concentration near generator-transformer bus.
- several protections needed.

The conventional protective relaying, therefore, becomes too complicated and unacceptable for generators of 500 MVA and above, as superior static-relays are now available.

33.21. STATIC, DIGITAL, PROGRAMMABLE PROTECTION SYSTEM FOR GENERATOR AND GENERATOR-TRANSFORMER UNIT

The static protection equipment for protecting generator-comprises solid state relays in form of plug in assemblies, associated auxiliaries, intermediate transformers, tripping programmes and testing facilities for circuits.

The Programmable, Numerical (digital) Microprocessor based Protection Systems have been introduced during 1990s. Table 32.6 gives a list of protections incorporated in the schemes for various sizes of generator-transformer units.

The major features and merits of such protection systems are :

A real-time microprocessor system utilizes sampled or preprocessed power system waveform data.

Digital filtering and numerical calculations take place on the bases of a continuous stream of data from the power system.

Programs, algorithms and settings are stored in the memory used by the microprocessor.

Extensive hardware and software monitoring ensures high availability.

The protection system can communicate with the Station Control System (SCS) and the Station Monitoring System (SMS), SCADA.

Event and disturbance recording on printouts, with time tagging is initiated by abnormal power system conditions, being afterwards available on request.

The interface for the man-machine communication (MMC) is either a personal computer, a mounted terminal or a remote terminal (with modem). Communication via the personal computer is menu-driven, highly structured, and provides full documentation of all the settings and recorded information.

The implementation of suitable algorithms allows an adaptive response by the protection functions to changing power system conditions and changed system parameters.

Protective Functions in two Groups

Two independent protective systems are provided for *Redundancy*.* In one of the protection system fails, the other operates, Table 32.6 gives a list of protective systems. The division in two groups (A and B) is given in Table 33.5.

* Redundant Protection : Additional, independent, duplicate protection, which is superfluous, can be avoided but is provided in important protection scheme.

Table 33.5
Two Independent Protection Schemes for Higher Availability

Type of fault	ANSI No.	Protection function	System
Generator stator			
Short circuits	87 G	Generator differential	A
	87 T	Overall differential	B
Asymmetry	21	Minimum impedance or as alternative	A
	51/27	Overcurrent/undervoltage (for thyristor excitation) or as option	B
	51	Overcurrent	B
Stator overload	46	Negative sequence	A
Earth fault, stator	49	Thermal	A
Earth fault, stator	59	Stator earth fault (90%)	A
Earth fault, stator	64	Stator earth fault (100%)	A B
Loss of excitation	40	Minimum reactance	B
Out of step	78/21	Pole slip	A
Motoring	32	Reverse power (dual protection for large generators)	A
Overspeed	81	Maximum frequency	B
Blade fatigue	81	Minimum frequency	B
Interturn fault	59	Overvoltage or overcurrent	A
Lower voltages	27	Undervoltage	B
Increased magnetization	24	Overexcitation (U/f)	B
Higher voltage	59	Overvoltage	A
Generator rotor			
Rotor overload	49	Thermal	B
Earth fault, rotor	64 R	Overvoltage	A
Step-up transformer			
Short circuits	87 T	Transformer differential	A
	50/51	Overcurrent	B
Earth fault	51 N	Earth fault overcurrent	A
	87 N	Restricted earth fault	B
Unit transformer			
Short circuits	87 T	Transformer differential	A
	50/51	Overcurrent	B
	49	Overload	A
Earth fault	(51 N)	Residual overcurrent (option)	A
	(87 N)	Restricted earth fault (option)	B

Summary

Alternator protection is complex. Most of the alternators are provided with % differential protection of phase to phase and phase to ground faults.

Differential relaying responds to vector difference between the current entering in the winding and current leaving the winding.

Bias of restraining coil is providing to prevent faulty tripping due to inaccuracies of CT's during through fault currents.

Unbalanced load cause rotor heating. Loss of input to turbine causes motoring action. (Ref. Tables 33.1, 33.2 and 33.3).

Loss of excitation causes generator to run as induction generator. The back-up protection against external faults is given by over-current and earth fault relays.

QUESTIONS

- Show in detail, the protection arrangement of a 60 MW generator provided with :
 - Differential protection
 - Back-up over-current protection through faults.
 - Standby earth fault protection in neutral connection.

[Hint. Refer Fig. 33.2 to 33.4 and 33.9].

- Explain, with the aid of neat diagram of connections, the principle of operation of current balance type differential protection of generator against earth and interphase faults.

A 3-phase, 11 kV, 15,000 kVA star connected alternator has differential protection. The neutral is earthed through a resistance of 8 ohms. The relay operates for out of balance of 18% full load. Calculate percentage of winding unprotected against ground fault.

- Fig. Q. 3 shows a differential protection system. The fault current for an earth fault on the winding are indicated. The CT ratio is 400/5. The relay is set to operate for current of 0.1 Amp. in its coil. Under the indicated conditions, will the relay operate? Relay is without bias.

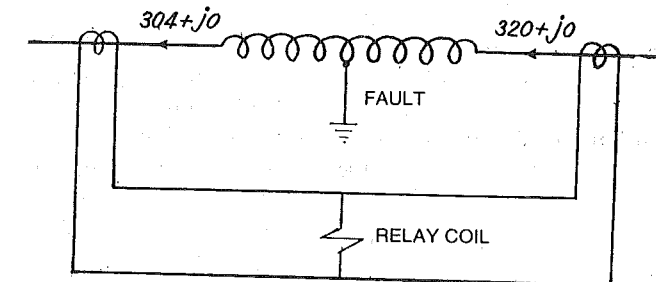

Fig. Q.3.

- What is differential protection? What is percentage differential protection? Why it is superior to simple differential protection. Explain the characteristic.
- What are the difficulties experienced in differential relay in generator protection? How are they overcome?
- What is the effect of balance load on the generator? Which part is damaged due to sustained unbalanced currents?
- Why field suppression is necessary?
- State the protections provided for a 100 MW generator.
- Why restricted earth fault protection is provided to alternators though it leaves a portion of winding unprotected against earth fault. Can it be justified?
- State effect of unbalanced load on the generator. What are the permissible durations of unbalance?
- State the effect of providing full excitation current to synchronous generator at 70% of synchronous speed. Which equipment in the generator-transformer unit will fail? which protection prevents such a failure.

Station Bus-Zone Protection

Introduction — Method of Protection — Use of Overcurrent/Impedance relays — Differential protection of buses — High impedance circulating current protection — High impedance voltage differential system — Check feature — Monitoring of Secondary Circuit — Autoreclosure — Interlock overcurrent protection — Bus transfer schemes — Summary.

34.1. INTRODUCTION

Buses are essential in both the power system and industrial switchgear. Busbar protection needs careful attention because,

- fault level at busbars is very high.
- the stability of the system is affected by fault in bus zone.
- the fault on busbar causes discontinuation of power to a large portion of the system.
- a fault on busbar should be interrupted in shortest possible time, *e.g.*, (60 ms), in order to avoid damage to the installation due to heating of conductors. Internal bus faults are less frequent than line faults. A bus fault tends to be appreciably more severe, both with respect to the safety of personnel, system stability and the damage. A major system shut-down can be caused by the lack of adequate bus protection.

The **desirable features** of bus protection include the following :

- high speed (less than 3 cycles).
- stability for external faults.
- discrimination between fault in its protected section and fault elsewhere.
- freedom from unwanted operation.
- no operation due to CT saturation or power swings.
- separate control of trip circuit of each circuit-breaker.
- 'main' and 'check' protection to assure the disconnection only when desirable.
- interlock overcurrent protection to trip generator unit if bus-zone protection operates.
- non-autoreclosure, no single pole tripping of circuit-breakers for bus-fault.

The bus-zone faults are generally single line to ground faults. However phase to phase faults can occur for medium and mediumhigh voltage buses. The **causes** of bus zone faults can be the following :

- failure of support insulator resulting in earth fault.
- flashover across support insulator during overvoltages.
- heavily polluted insulator causing flashover.
- failure of connected equipment.
- earthquake, mechanical damage, etc.

Table 34.1. Methods of Bus Zone Protection

Method	Particulars	Remarks
Bus-protection by overcurrent relays, of connected circuits.	High-set instantaneous overcurrent relays and earth fault relays, or definite time relays.	Used in distribution system (6—33 kV) with transformers feeder supply to bus bars. Time of the order to 100—400 ms.
Bus-protection by differential protection.	<ul style="list-style-type: none"> — High impedance circulating current differential protection. — High impedance differential protection based on voltage drop. — Biased differential protection. 	Used in major stations. <ul style="list-style-type: none"> — High impedance connected in series with relay coil to improve stability. — Voltage drop across impedance is measured for discrimination. — Biased coil gives restrain for external faults.
Frame-leakage earthfault protection.	The metal frame of switchgear (lightly insulated from earth) earthed only through a CT. Earth fault relay connected to secondary of the CT.	Earth fault protection of metal clad switchgear (Ref. Sec. 27.10).
Static protection.	Rapid reliable, no problems of CT saturation.	Preferred in modern installations.
Back-up protection	Overcurrent protection or Distance protection.	The zone of primary protection of feeders is extended to cover bus-zone.
Overvoltage protection	Inverse overvoltage relays.	Connected to bus-VT
Surge voltage protection	Surge arresters	Connected phase to ground for line and for transformers

34.2. BUS PROTECTION BY OVERCURRENT RELAYS OF CONNECTED CIRCUITS

The graded overcurrent and earth fault protection on incoming feeders can provide bus-protection. Such bus protection is provided as primary protection only when no other primary bus zone protection is applied. In case other primary (main) bus zone protection is applied, the overcurrent and earth fault protection of incoming circuits act as a back-up protection to the bus-bar. Fig. 34.1 illustrates this principle. The fault on bus A can be sensed by overcurrent relay (O) of the incoming circuit, and is disconnected by opening of incoming circuit. The overcurrent protection of incoming feeder gives protection to the bus. The disadvantage of such system is :

- delayed action.
- disconnection of more circuits in case there are two or more incoming lines.
- exact discrimination not possible, zone not clearly be used

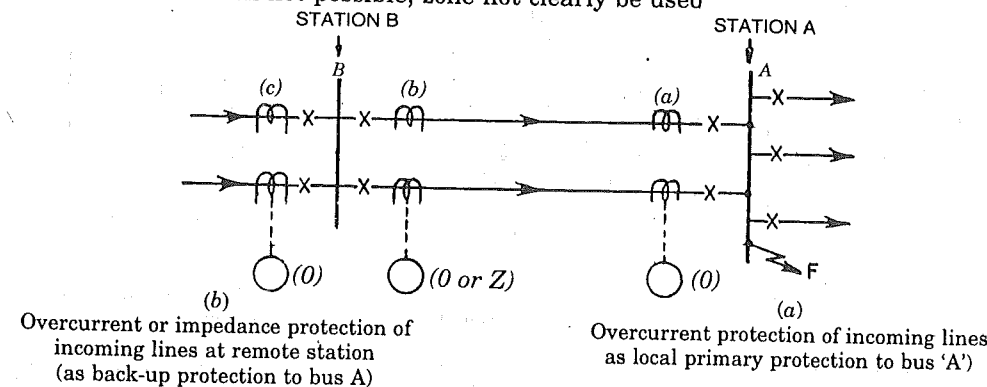

Fig. 34.1. Bus-protection at station A by (a) local overcurrent protection on incoming lines as primary protection. (c) Overcurrent or impedance protection at remote station (B) as a back-up to (b).

To isolate the bus fault all incoming lines connected to the bus must be opened. Since such disconnection may include generating sources as well as transmission lines, it is important to have correct operation of bus zone protection for internal faults only. Hence bus protection by overcurrent relays of other zones is not a satisfactory solution. It is used only distribution systems. However, such a protection always provides a back-up protection for bus-zone. The primary protection being generally differential protection.

34.3. BUS PROTECTION BY DISTANCE PROTECTION OF INCOMING LINE AS A REMOTE BACK-UP

Referring to Fig. 34.1 again, the Bus A is covered in the second step of distance protection B. Thus, for a fault F on bus A, the distance protection B will operate. The operating time of the second step can be of the order of 0.4 seconds. In this system also, the protection is slow and there can be unwanted disconnection of all incoming parallel circuits. Distance protection is widely used in protection of transmission lines, hence it is often economical to use the same for bus protection. However, due to the limitations mentioned above, it is not desirable for important buses.

Referring to Fig. 34.1, considered the protection of bus-zone in station A.

(a) The local overcurrent protection at station A provides the primary protection to Bus-Zone A.

(b) The remote overcurrent protection or impedance protection at station B provides a back-up protection to bus-zone A so that if protection 'a' fails, protection 'b' gives a back-up.

(c) Local overcurrent protection of incoming lines at station B provide primary protection to bus B.

34.4. BUS-ZONE PROTECTION BY DIRECTIONAL INTERLOCK

Normally the busbars receive power from *source circuits*, and send power to *load circuits*. For internal faults within the bus-zone, the power will flow towards busbars from all circuits. For external fault in one of the circuits, the power will flow from busbar towards that circuit. Thus, if direction of power flow in each source and load circuit is sensed by respective directional relay, it should be possible to discriminate between internal fault and external fault for Bus-zone protection.

Ref. Fig. 34.2 (b) During the external fault on load circuit Direction of power flow from source circuits remains unchanged. However direction of power flow from load circuits is likely to be reversed. For a severe fault, the overcurrent relays of load side may operate but the directional relays on source circuit do not operate.

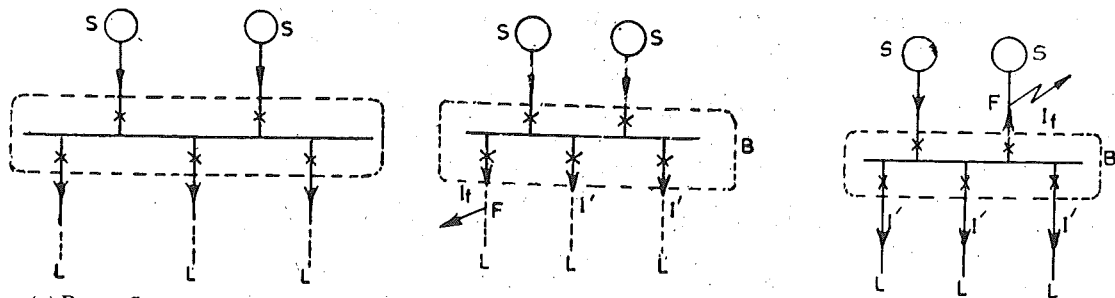

(a) Power flow-normal condition. (b) External fault in load circuit. (c) External fault in source circuit.
Fig. 34.2. Bus-zone protection Directional Interlock. (Ref. d for symbols)

For external fault on source circuit the directional relay of that circuit will operate. (Fig. 34.2 c) and current flowing in load circuit is substantially reduced.

The principle of *Directional Comparison* was adopted in earlier schemes. The scheme comprised directional relays in source circuits and overcurrent relays in load circuits. The contacts of these

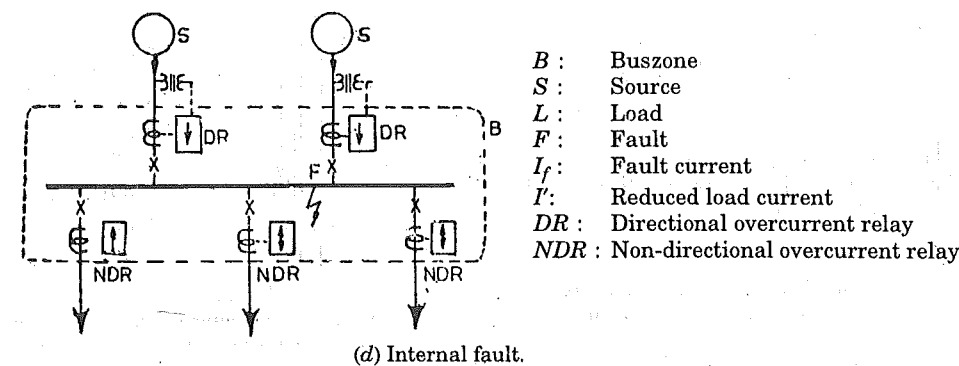

(d) Internal fault.
Fig. 34.2. Bus-zone protection by directional interlock.

relays are suitably *interlocked* in such a way that if power flows towards the busbar from the source circuit and the current flowing away from the busbars (I') is sufficiently low, the entire bus-zone protection acts and all the circuit-breakers on load side and source-side are tripped. (Fig. 34.2. c)

The contact system of such protection is quite complex. Hence such system was adopted only for earth fault protection. The system was too slow. Hence the directional comparison scheme is not preferred for busbars of high fault power and important sub-stations. It is used in distribution systems to achieve selectivity in bus-zone protection. (Ref. Sec. 43.8 for static Directional Comparison).

Phase Comparison Protection

In this method, two instantaneous relays are connected in rectifier bridge circuit. During internal faults, the contacts of both relays close and the trip circuit is closed. For external faults, the contacts of both relays do not close and trip circuit is not energized. This type of protection was tried during 1940's.

34.5. BUS-ZONE PROTECTION BY DIFFERENTIAL PRINCIPLE

The 'differential protection' is a wide term applied to protections which responds to vector difference between two or more similar electrical quantities. A simple method of bus bar protection is by comparing the vector-sum of currents entering and leaving the bus-zone. *In absence of internal fault*, the vector sum of currents entering the bus-zone is equal to the vector sum of currents leaving the bus-zone. In other words,

$$\Sigma I_n = \bar{I}_1 + \bar{I}_2 + \bar{I}_3 + \dots + \bar{I}_n = 0$$

where $\bar{I}_1, \bar{I}_2, \dots, \bar{I}_n$ etc. are currents in the circuits connected to the bus bar (Ref. Fig. 34.3).

During internal fault the vector sum of currents in the circuits connected to bus bar is equal to fault current, i.e.

$$\bar{I}_1 + \bar{I}_2 + \bar{I}_3 + \bar{I}_4 + \dots + \bar{I}_n = \bar{I}_f$$

The out of balance current flows through the fault.

In differential protection of busbar, CT's are connected in each circuit connected to busbar. The secondaries of these CT's are connected in parallel with due considerations to polarity and phase.

The relay coil is connected across the pilot wires in such a way that the summation current of secondaries passes through the relay.

Referring to Fig. 34.3, the normal condition or external fault, the summation of secondary currents $\Sigma i_n = 0$.

For internal faults $\Sigma i_n \neq 0$.

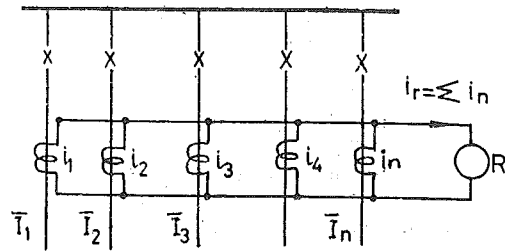

For normal condition : $\sum i_n = 0$
for internal fault : $\sum i_n \neq 0$

Fig. 34.3. Bus-zone protection based on differential principle. (Single line diagram).

The $\sum i_n$ flows through relay coil.

CT connections depend upon type of protection desired. For example, in simple earth fault protection scheme the CT connections are as follows (Fig. 34.4). The primaries are connected in each incoming and outgoing circuit (one in each phase). The secondaries are connected in parallel and are connected to the measuring relay. For external fault (F_2), or for healthy conditions, the sum of currents entering the bus is equal to sum of current leaving the bus, (Kirchhoff's Law). Hence the secondary currents sum up to zero and relay gets no current.

The connections of CT's for protection of sectionalized bus are illustrated in Fig. 34.5. The CT's are arranged on both sides of busbar sectionalizing breaker so the protections overlap and no 'dead holes' are left in the busbar.

To obtain phase fault and earth fault protection, the four pilot wire scheme (Fig. 34.6) can be employed.

In the schemes described above, stabilising resistors are used in series with instantaneous measuring element in order to avoid wrong operation of the relay on spill currents. The spill current can be caused by saturation of a CT.

34.6. PROBLEMS IN BUS-ZONE DIFFERENTIAL PROTECTION

The basic problems are the following :

- Large number of circuits, different current levels for different circuits for external faults.

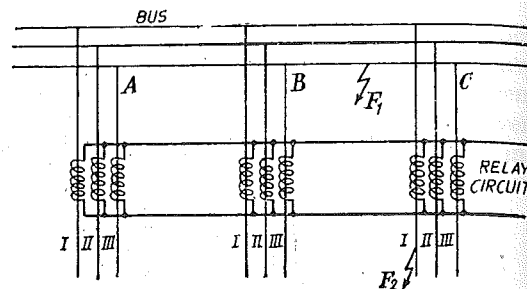

I, II, III : Phases of A/B/C
A, B, C : Incoming/Outgoing Circuits.
 F_2 : External fault F_1 : Internal fault.

Fig. 34.4. Connections of CT's for simple earth fault protection.

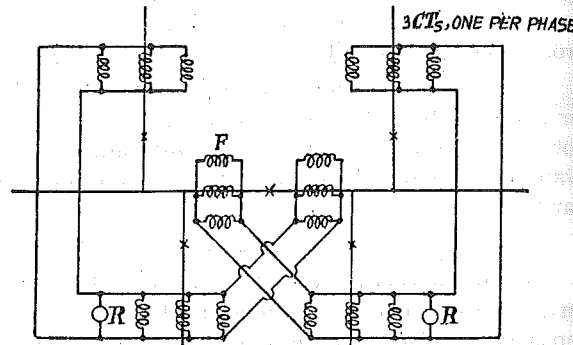

R = high impedance relay.

Fig. 34.5. Earth fault protection of sectionalised bus by circulating current differential.

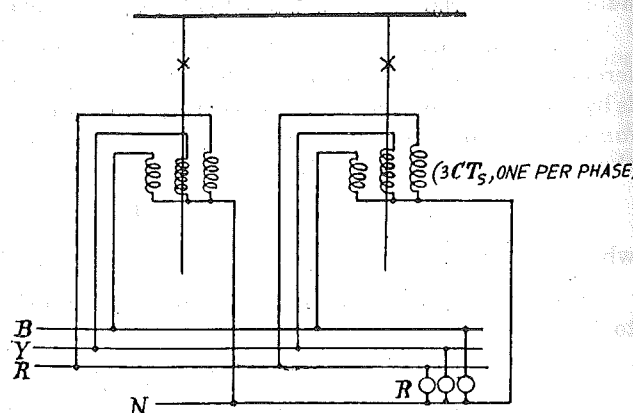

Fig. 34.6. Pilot wire scheme for protection against phase faults and earth faults.

- Saturation of CT cores due to d.c. component and a.c. component in short circuit current. The saturation introduces ratio-error.
- Sectionalising of bus makes the circuit complicated.
- Settings of relays need a change with large load changes.

34.7. SELECTION OF CTS FOR BUS-ZONE PROTECTION

In the protective schemes requiring close balance of secondary currents in various phase circuits, the CT ratio error should be low. The CTs for such protection should be selected such that the balance is maintained for maximum through fault current in primary of any of the phase under transient conditions and also steady conditions.

The large power system have a large X/R ratio. The d.c. component of fault current decays slowly and the CT cores remain saturated for longer duration (5 to 30 ms) since CT core gets magnetized with unidirectional component of fault current. The residual flux present in the core has a direction which depends on the instantaneous condition at the end of earlier switching. The residual flux also depends upon the remanance of CT core material. The total flux is caused by d.c. component, residual flux, a.c. component. If residual flux is in same direction as that of d.c. component, the core may saturate and harmonic spill current will flow through the relay coil.

The following aspects are considered while selecting CT's for differential bus-zone protection.

1. Use of identical CT's in which saturation occurs at large short-circuit currents.
2. Increasing CT ratio 'n' (Ref. Sec. 35.10) so as to decrease. The ratio of I_{sh}/I_1 , I_{sh} is fault current and I_1 , is rated primary current.
3. Selecting as large core as economically and technically suitable thereby increasing limiting value of secondary current (i_n) for saturation of core.
4. Reducing the burden on CT's by using pilot wires of lesser resistance, static relays.
5. Use of intermediate CT's (Ref. Fig. 35.11) with gapped core.

When an internal bus fault occurs, the magnitude of the fault current and its d.c. component may be so large that the line CT's (current transformers) saturate within 2.4 ms. In such cases it is essential that the bus differential protection operates and seals in within 2 ms, i.e., prior to the saturation of the line CT's. This high speed is necessary because when a line CT saturates its output e.m.f. tends to drop to zero.

In the event of an external fault, just outside the line CT's of a relatively small feeder, the fault current may in an extreme case be as large as 500 times the rating of the feeder. The lines CT's of the faulty feeder are then likely to saturate at higher speed. If the remanance in the core from a previous fault has an unfavourable polarity. The response of the restraint circuit to the differential relay must therefore be of atleast the same high speed as that of the operating circuit, if mal-operation is to be avoided.

Ref. Ch. 35 for stability of differential protection, the spill current through the relay should be less than the relay setting. i.e.

$$I_{eb} - I_{ea} < I_r$$

The CT error is minimum if the core does not get saturated for flux of the order of X/R times the normal current flux where X/R are ratios of equivalent reactance and resistance on source side of the fault. For large generating systems, equivalent X/R of source upto the fault point can be high as 20. Therefore, to avoid saturation, very large cores would be necessary. This makes the CT's prohibitively uneconomical. The CT's can be designed for higher value of a.c. component but they cannot transform the d.c. component.

Simple circulating current differential systems with low impedance attracted armature relay (operating time of 0.1 sec.) can operate during external faults due to the above mentioned reason. Induction type IDMT relays with time setting of several seconds do not operate for external faults

because the transient component vanishes within a few hundred milliseconds and the relay gets reset. However, IDMT relays are slow and are not preferred for protection of buszone. However, busbar differential protection with IDMT relay unit was superior to the simple overcurrent protection described in sec. 34.2.

To overcome the problem of CT saturation and to improve the stability without intentional time delay, various modifications have been developed. These include the following :

- biased differential buszone protection.
- high impedance bus-zone protection.
- high impedance voltage differential bus-zone protection.

Note : 'High Impedance' refers to relay unit. This is quite different from impedance protection of transmission lines.

The principles of these schemes are described below :

34.8. BIASED DIFFERENTIAL BUS-ZONE PROTECTION

In biased differential protection, the relay element has a restraining coil in addition to the operating coil. The circulating current flows through the restraining coil and the spill current flows through the operating coil. For external faults, the restraining current is more and the relay does not operate. For internal faults operating current is more and the relay operates.

34.9. HIGH IMPEDANCE CIRCULATING CURRENT DIFFERENTIAL BUS-ZONE PROTECTION

By inserting a resistance in series with relay operating coil of differential protection the spill current through the relay can be reduced. The resistance connected in series is called stabilizing resistance. The relay is called *High Impedance Relay*. High impedance differential protection is an alternative to biased differential protection. It is simpler and effective. The basic principle of high impedance protection is same as that of differential protection. The circuit connections are also similar. (Figs. 34.4, 34.5, 34.6 etc.).

High impedance relay unit is the attracted armature type instantaneous relay with setting of the order of 25 mA. A relatively high stabilizing resistance is connected in series.

In some high impedance relays a capacitor and resistances are connected in series with the relay operating coils. The capacitors blocks the d.c. component and makes the relay insensitive to the d.c. component in short-circuit current.

34.10. HIGH IMPEDANCE DIFFERENTIAL PROTECTION BASED ON VOLTAGE DROP (Fig. 34.8)

This relaying is based on differential principle. During normal condition the vector sum of currents in the arrays is zero. During fault on bus-bar the balance is disturbed. The out of balance current I flows through the high impedance Z_H producing voltage drop V_{ZH} . This voltage is supplied to relay measuring unit M through transformer T . During faults on bus-bars the trip circuits of all the circuit breakers are closed by the same relay, thereby the bus-bar is rapidly disconnected.

If the relay measuring system responds to voltage drop instead of circulating current, the saturation of one of the CT's does not cause instability of protection.

During external fault, one of the CT's may saturate. Thereby its output will be reduced and the vector sum of secondary currents will not be zero. The resultant unbalance current would cause the relay operation. However the voltage drop across the CT under saturated condition will be limited by the IR drop in its secondary, IR drop in leads which is relatively low. However, the voltage drop across secondary of CT does not increase but approaches to zero under saturated condition. Hence V_{ZH} reduces.

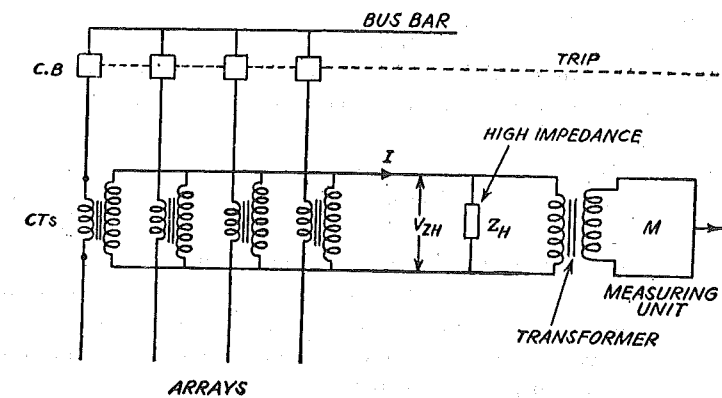

Fig. 34.7. High impedance bus-bar protection based on voltage drop.
Courtesy : Brown Boveri, Switzerland.

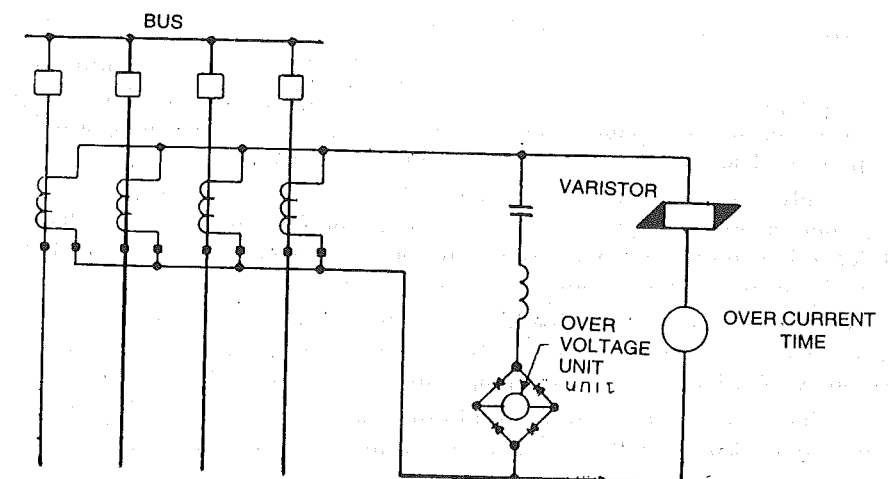

Fig. 34.8. Schematic of the High Impedance Voltage Differential System.
Courtesy : Westinghouse Electric Corporation (U.S.A.)

However, during internal bus-fault all the secondaries will be feeding the current into the impedance Z_H . Hence voltage drop V_{ZH} increases and this increase is sensed by the relay.

34.11. HIGH IMPEDANCE-VOLTAGE DIFFERENTIAL SYSTEM

This scheme utilizes conventional CT's but the problem of saturation is avoided by high impedance relay unit. The basic principle is similar to that described in sec. 34.10. Resistance of the CT secondary circuits must be kept low. This limits the applications to bushing type current transformers only. These have a toroidally wound core where the leakage reactance is negligible, and hence, secondary impedance is low. It is further important to have all current transformers with the same ratio, to operate the bushings on full tap and to parallel the several transformers in the switchgear as near as possible to the current transformers. Auxiliaries to match ratios should not be used as all transformers must have the same ratios.

The discrimination between internal and external faults is made by the magnitude of the voltage applied to the relay. On internal faults, the voltage is high, approaching the open circuit voltage of the current transformer secondaries. Thus, the current transformer, leads and relay are subjected to voltages of the order of 1000 volts. On external faults, the voltage should be low and will be

essentially zero unless unequal saturation of the current transformers exists. The maximum voltage occurs when one CT is completely saturated, with no saturation in the others, and will be the resistance drop of the theoretical secondary current through the leads and secondary winding of the saturated current transformer. The relay is set by calculating this maximum possible voltage and applying a safety factor of 2/1.

The relay unit shown in Fig. 34.8 is an instantaneous voltage plunger unit operated through a full-wave rectifier. The capacitance and inductance tune the circuit to fundamental frequency to reduce response to all harmonics. The impedance of this branch is around 3000 ohms, which means that CT secondaries and relay are subject to high voltages on a bus fault.

A thyrite voltage limiting unit is connected in parallel with the relay to limit the voltage to about 1500 volts. In series with this is an instantaneous overcurrent unit, set to operate at very high internal fault magnitudes. It must be set high to avoid operation on external faults. In addition contacts on the auxiliary tripping relay are used to short circuit all current transformers after the relay trips. The time of operation of the relay is three to six cycles for the voltage unit one to three cycles for the overcurrent unit.

34.12. CHECK FEATURES IN BUS PROTECTION

The methods of applying additional relays for increasing the reliability of bus differential schemes vary appreciably from one manufacturer to another. The unwanted opening of a CT secondary circuit has been of particular concern, because this may lead to maloperation of a bus protection during normal service condition resulting in embarrassment.

Some supply companies permit tripping of the bus zone protection if a CT secondary is open-circuited, whereas other companies require an alarm only, without tripping. The method which is adopted depends is often on scheme reliability of CT secondary wiring and whether tripping can be accepted from the system stability point of view.

Bus zone protection schemes should not be allowed to trip by the closing of one relay contact only. Two separately actuated relays, with their contacts in series are then required to operate simultaneously in order to achieve tripping. This is called check feature.

Since maloperation of a bus differential protection may lead to a complete system shut-down, the alarm relay is also normally arranged to disconnect the main tripping relay after a time delay of about 5 seconds.

It is desirable to be doubly sure about the fault in bus zone before de-energising the bus section. With this understanding, check feature is generally added to the differential bus protection in important and large power stations. Both main protection and check-feature can be of circulating current type or check feature can be overcurrent starter. Check feature operates from separate current transformers. The trip-circuit is controlled by connecting the main protection contacts and check feature contacts in series. Thereby, the trip circuit is closed only if check feature and main protection operate.

34.13. LOCATION OF CT'S

The location of CT's determines the boundaries of protective zones. CT's for bus protection are generally arranged such that circuit breakers are also covered by the protection and are not left unprotected. (Ref. Sec. 25.3).

34.14. MONITORING OF SECONDARY CIRCUITS

CT secondaries should not be open circuited, and there should be no open circuit in continuity of pilots. For this purpose an alarm relay is provided to monitor the continuity. If discontinuity occurs, the alarm relay gets actuated and gives an alarm, after some delay it may trip the bus circuit-breakers.

34.15. INTERLOCKED OVERCURRENT PROTECTION FOR BUSZONE AND GENERATOR-UNIT ZONE

The boundaries of the bus-zone protection and protection of generator-transformer are determined by location of CT's of respective differential protections. (Ref. Fig. 34.9).

The busbar protection will act for faults, internal to bus-zone such as a fault shown in the figure.

The unit protection will act for faults upto the CT of the unit protection.

What happens for a fault between the circuit-breaker and the CT of unit protection? This fault (shown in the figure) comes in bus-zone protection and is detected by Bus-zone unit. Therefore bus zone protection will act and trip the circuit-breaker.

However the fault is not internal to the unit protection zone and will not cause shut down of the generator transformer unit. The generator will therefore keep on feeding the fault. A special overcurrent relay called Interlocked overcurrent relay (IOC) is used in such cases to trip the generator unit.

Interlocked overcurrent protection is employed for discrimination between a busbar fault and a fault between CT and circuit-breaker.

Interlocked overcurrent relay (IOC) is energized by a set of CT's as shown in Fig. 34.9. Usually it is an induction disc relay with summation input winding and separately brought out secondary winding or shading winding. (Ref. Fig. 34.10).

For a fault shown in the figure, the busbar protection acts and closes the circuit of tuned shading coil of IOC relay. Thereby the IOC relay acts, and closes the contacts of generator trip circuit. (Ref. Fig. 34.9 and 34.10).

For faults in generator-transformer unit zone, the unit protection will act. The fault is external to bus-zone. The bus-zone protection is not likely to operate.

The interlocked overcurrent relay (Fig. 34.10) acts when the operating coil current increases above pick-up value and the circuit of tuned shading coil is completed by operation

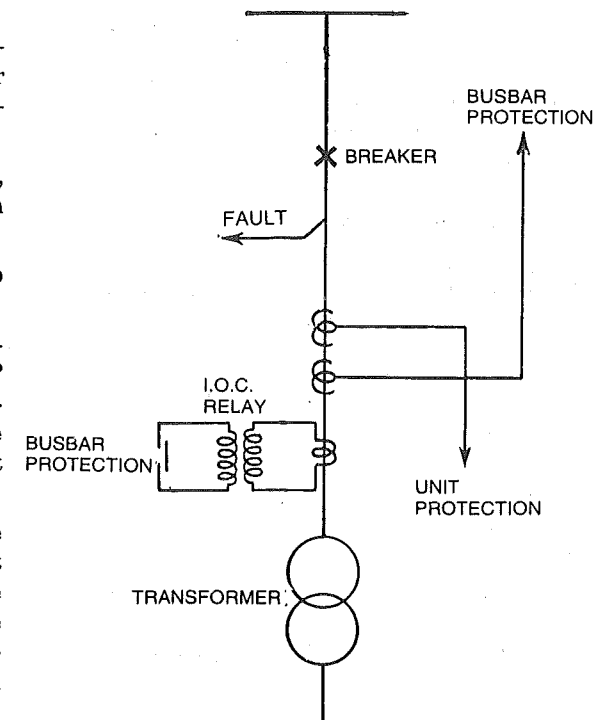

Fig. 34.9. Interlocked overcurrent protection.

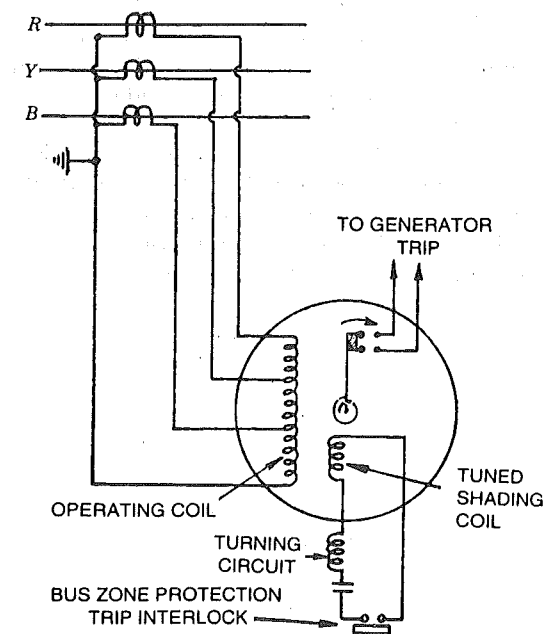

Fig. 34.10. Interlocked overcurrent relay.

of busbar protection trip interlock. (The interlock contacts of shading coil circuit are closed as the bus-bar protection operates.). Hence two conditions are to be satisfied :

- generator should supply overcurrent
- busbar protection should act.

Timelag of 0.1 to 0.5 sec may be provided when these two conditions are satisfied, the IOC relay of that generator-unit operates and closes trip circuit of that generator. Thereby the generator unit stops feeding the fault.

34.16. NON-AUTO RECLOSURE AND SIMULTANEOUS THREE-POLE OPERATION

The fault in bus-zone or generator transformer units are generally non-transient. After opening of circuit breaker, the cause of fault should be ascertained. Auto reclosure should not be carried out. Reapplication of voltage will cause further damage. Hence the generator-transformer protection and bus-zone protection should be non-autoreclosing type.

Single pole operation of circuit breaker for single line to ground fault bus zone will lead to unbalanced loads on generator units leading to damage of rotors (Ref. Ch. 33). Hence the protection and circuit breakers associated with bus-zone protection and generator protection must be arranged for

- non-autoreclosure
- three phase simultaneous operation

The autoreclosure and single pole operation is restricted to protection of overhead transmission lines, with stability considerations.

34.17. BUS TRANSFER SCHEMES FOR AUXILIARY SWITCHGEAR AND INDUSTRIAL SWITCHGEAR

In continuous process installations, momentary power failure can lead to serious losses or damage. If the incoming power is interrupted due to tripping incoming circuit-breaker, there should be a very quick (within few cycles) change over or transfer of load to an alternate source. Such schemes are known as Bus-transfer schemes or Transfer Schemes.

Manual transfer schemes are used in non-critical processes where shut down of several minutes can be allowed. The operator closes and trips circuit-breakers in a specific sequence so as to transfer the load to alternate source.

Ref. Fig. 34.11, in the event of loss of supply from circuit 1, circuit-breaker *A* is opened and circuit-breaker *X* closed, so as to transfer the load from source 1 to source 2.

In automatic bus-transfer schemes, the process of opening and closing the circuit-breakers *A/X/B* is much faster and automatic. The scheme depends upon the type of load, whether transformers T_1 and T_2 can be momentarily paralleled, timing of bus transfer etc.

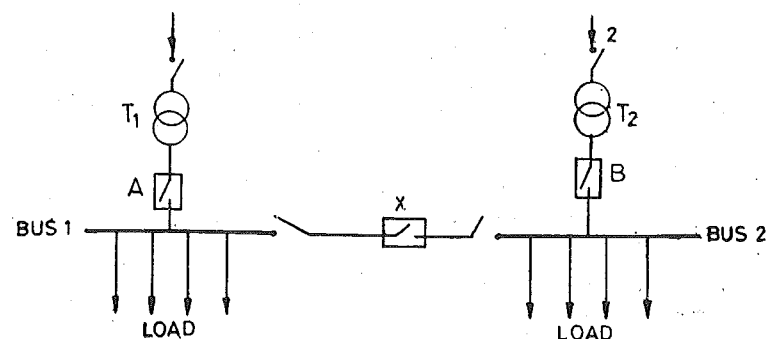

(When supply voltage 1 is lost, breaker 1 is opened and breaker *X* closed to transfer the load from source 1 to source 2).

Fig. 34.11. Explaining bus transfer scheme.

Consider lighting load on the buses. The breakers *A* and *B* can be kept closed and *X* open. During failure of supply 1, breaker *A* is opened and *X* closed with a slight delay or simultaneously. The lighting load does not give current inrush and consequent voltage dip on the transformer bus.

If the loads are motors ; the transfer scheme becomes complicated because, as the breaker *A* is opened, the motors on bus 1, keep on rotating and generate voltage. This residual voltage makes faster closing of circuit-breaker *X* harmful. Such closing will cause high inrush currents. The breaker *X* should be closed when motor is still running and residual voltage has reduced. This will reduce the inrush currents sufficient magnitude.

Bus-transfer schemes are used in auxiliary switchgear in thermal power station (Ref. Sec. 17.3).

SUMMARY

Bus-zone protection should be stable for external faults and very fast for internal faults.

Circuit-breakers in incoming and outgoing circuits are also covered by bus zone protection.

In smaller installations, overcurrent or impedance protection of incoming circuits gives protection to busbars. However such system is slow and does not give satisfactory discrimination.

Differential protection is used as a primary bus-zone protection. CT's are connected in incoming and outgoing circuits. The high-impedance relay or biased differential relay is connected such that out of balance current during internal faults, flows through the relay.

The high impedance relay is an overcurrent relay with a series resistance. Such a relay remains stable against spill currents due to external faults or CT inaccuracies.

Selection of CT's is very important and difficult task in bus-zone differential protection.

Interlocked overcurrent protection is necessary to trip generator unit during a busbar fault.

The main protection is supplemented by check-feature in order to be doubly sure about bus-zone fault.

There is also a provision for monitoring CT secondary circuits.

Frame leakage protection is sometimes employed for metal enclosed switchgear.

HRC fuses are used for low voltage bus protection.

QUESTIONS

1. Discuss one of the following :-
 - (a) Interlocked overcurrent protection.
 - (b) Differential protection of bus-bars.
2. Explain the necessity of check feature in bus bar protection
3. Describe the earth fault protection of sectionalised bus.
4. Write short note on any one :
 - (a) High impedance differential protection of bus.
 - (b) Location of CT's with respect to CB location.
5. Discuss the protection of a bus bar as back-up from other station apparatus.
6. What are the likely causes of failures of outdoor bus bars?
7. How are the outdoor bus bars protected against lightning ?
8. Give a sketch of differential protection of station-bus.
9. Discuss the effect of short-circuits currents on CT performance. How does it effect the differential protection. What are the possible modifications to overcome the problem?
10. Describe the principle of high impedance differential protection based on voltage drop.
11. Describe the principle of bus bar protection based on voltage differential systems. How does it respond to saturation of CT's for external fault and internal fault?
12. Describe the interlocked overcurrent protection between generator and busbar. Explain its necessity.

Current Transformers and their Applications

Introduction, Specifications — Burden — Accuracy — Magnetization curve — Secondary current ratings — Class of accuracy — Polarity — Open circuited secondary — CT's for protection — Effect of transients — CT's for circulating current protection — Procedure of calculating the error — Types of construction — Testing of CT — Selection of CT's for Protective Relaying — Transient Performance of CT's.

35.1. INTRODUCTION

Protective relays in a.c. power systems are connected in the secondary circuits of current transformers and potential transformers. The design and use of these transformers is quite different from that of well known power transformers. In current transformers, primary current is not controlled by condition of the secondary circuit. Hence primary current is a dominant factor in the operation of current transformers. Current transformers must be further classified into two groups :

1. Protective current transformers used in association with relays, trip coils, pilot wires etc.
2. Measuring current transformers—used in conjunction with ammeter, wattmeter etc.

As a rule, the ratio error is very important in protective current transformers, and phase angle error may be less important.

Voltage transformer is used for transforming voltage from one value to another (generally lower) value.

Both current transformers and voltage transformers come under the little 'Instrument Transformers.'

As the relay time has reduced to the order of a few milli-seconds in modern protective relays, the transient behaviour of current transformers and voltage transformers need more attention. In order to prevent saturation of current transformer cores during sub-transient currents, larger cores and air gaps are introduced in CT's for fast protective relays.

The Standard Specifications given by IEC and BIS cover several aspects about current transformers such as requirements, specification, testing, application, terms and definitions etc. These should be referred.

The major criterion of selection of the current transformer is the ratio at maximum load current through primary and secondary. In other words, the current transformer secondary current at maximum load should not exceed the continuous current rating of the applied relay. This is particularly applicable to phase type relays where load current flows through the relays. This criterion applies indirectly to the ground relays even though they do not receive load current because they are generally connected to the same set of current transformers as the phase relays. Since the ratio has been set on the basis of load current for the phase relays, this ratio would then apply to the ground relay. Thus, the current transformer ratio should be selected to provide around 5 amperes secondary for the maximum load current. Some relays can carry up to 10 amperes and the ratio can be selected accordingly. Where delta-connected CT's are used, the $\sqrt{3}$ factor should not be overlooked.

35.2. TERMS AND DEFINITIONS

(a) **Instrument transformer.** The transformers which are used in conjunction with measuring instruments, protective relays and control circuits. Instrument transformers include measuring and protective current transformers and voltage transformers.

(b) **Current transformer.** Instrument transformers used in conjunction with ammeters, over-current relays, etc. Current transformers step down current from high value to a low value. Their current ratio is substantially constant for given range of primary current and phase angle error is within specified limits. The VA rating of current transformers is small as compared with that of a power transformer.

(c) **Rated Primary Current.** The value of primary current on which the performance of the current transformer is specified by the manufacture [Ref. Sec. 35.9 (a)]

The maximum permissible temperature-rise of a current transformer carrying its rated continuous thermal current is given in Sec. 35.9. Unless otherwise specified, the rated continuous thermal current is equal to the rated primary current. It should therefore, be noted that normally current transformers have no continuous overcurrent rating. When selecting a current transformer, therefore, the rated primary current should be so chosen as to make it suitable for all but the momentary overcurrent that will occur in service. Where intermittent overcurrents are frequent and severe, the manufacturer should be consulted as to a suitable current rating.

Rated primary current is assigned after conducting heat run test. (Ref. Sec. 10.12.2).

(d) **Rated short time Current (primary).** It is defined as r.m.s. value of a.c. component of current which the CT can carry for rated time without damage due to thermal or electrodynamic stresses.

The heating effect depends on the average r.m.s. value of the primary current and its duration of flow through the current transformer, whereas the mechanical stresses due to the electromagnetic forces set up in a current transformer depend on the peak value of the rated dynamic current. The rated dynamic current being in turn dependent on the rated short-time thermal current, it is desirable that purchasers should inform the manufacture regarding the magnitude and duration of the short-time thermal current to be withstood.

The short-time current is associated with time, (Rated duration of short-current) which may be 0.25, 0.5, 1, 2.0 or 3 seconds.

The short-time current rating is proved by conducting short-time current tests (Ref. Sec. 11.6).

(e) **Rated Secondary Current.** The value of secondary current marked on the rating Plate. [Ref. Sec. 35.9 (a)]

(f) **Rated Transformation Ratio.** The ratio of the rated primary current to rated secondary current.

(g) **Actual Transformation Ratio.** The ratio of the actual primary current to the actual secondary current.

(h) **Exciting Current.** The r.m.s. value of current taken by the secondary winding of a CT when sinusoidal voltage of rated frequency is applied to secondary, with primary winding open circuited.

(i) **Rated Saturation Factor.** The ratio of rated primary saturation, current to rated primary current.

(j) **Rated Primary Saturation Current.** The maximum value of primary current at which the required accuracy is maintained.

(k) **Overcurrent factor.** The ratio of Rated Short-time current to rated primary current.

(l) **Burden.** The value of load connected across the secondary of CT, expressed in VA or ohms at rated secondary current.

(m) **Rated Burden.** The burden assigned by manufacture at which the CT performs with specified accuracy.

(n) **Current Error or Ratio Error.** The percentage error in the magnitude of the secondary current is defined in terms of Current Error.

$$\% \text{ Current Error} = \left(\frac{k_n I_s - I_p}{I_p} \right) \times 100$$

k_n = Rated transformation ratio

I_s = Actual secondary current for I_p

I_p = Actual primary current.

(o) **Phase angle error.** The phase angle between primary current vector and the reversed secondary current vector.

(p) **Rated accuracy limit primary current.** The highest value of primary current assigned by the manufacture of CT, upto which the limits of composite errors are complied with.

(q) **Composite Error.** The r.m.s. value of the difference $(k_n i_s - i_p)$ integrated over one cycle under steady condition, given by

$$\text{Composite error} = \frac{100}{I_p} \sqrt{\frac{1}{T} \int_0^T (k_n i_s - i_p)^2 dt}$$

where k_n = Rated transformation ratio

I_p = Primary current, r.m.s.

i_p = Primary current, instantaneous

i_s = Secondary current, instantaneous

T = Time of one cycle, in sec.

35.3. ACCURACY CLASS

The class assigned to the current transformer with the specified limits of ratio error and phase angle error.

For relaying purpose the ratio-error becomes important. Generally the load on the secondary side of CT is at such a high lagging power factor that the secondary current is almost in phase opposition with the magnetising currents and, therefore, phase angle error is negligible. Ratio error is very significant because the currents are high during short-circuit conditions.

Ratio Error is expressed as

$$\% \text{ R.E. at } I_p = \left(\frac{K_n I_s - I_p}{I_p} \right) \times 100$$

where % R.E. = %ratio error

I_p = r.m.s. value of current in primary.

I_s = r.m.s. value of current in secondary.

K_n = Nominal ratio = $\frac{\text{Rated primary current}}{\text{Rated secondary current}}$

In general the percentage ratio error increases with increase in primary current. Refer table 35.1, to get an idea of permissible error.

Table 35.1. Limits of Error [Ref. Sec. 35.9 (d)]

Accuracy class	Current Error at Rated Primary current	Phase Displacement at Rated Current	Composite Error Rated Accuracy Limit Primary Current
	Per cent	Minutes	Per cent
5 P	± 1	± 60	5
10 P	± 3	—	10
15 P	± 5	—	15

The current transformers are marked as follows [e.g., 30/5 P 10] where, first number : output in VA (i.e. 30),

Second number : accuracy class (i.e. 5 P).

Last number : composite error (i.e., 10).

The class of accuracy required for protective current transformer depends upon the particular application. These aspects are discussed below :

For Instantaneous Overcurrent Relays and Trip Coils, class 15 P protective current transformers are generally sufficiently accurate. Rated accuracy limit factor of 5 should be enough. However, when the instantaneous overcurrent relays are set to operate for high values of overcurrents, say 6 to 16 times of rated primary currents, the accuracy limit factor should have atleast the value of the setting used.

The current transformers for high set overcurrent relay may be allotted higher rated primary current thereby reducing the required accuracy limit factor.

For IDMT relays class 10 P current transformer is preferred for system networks discrimination is obtained by graded time lag. Where close discrimination is not desired, class 15 P may be preferred.

For residually connected Inverse and Definite Minimum Time Earth fault relays, the choice of accuracy class of CT depends on characteristic and arrangement of protective system. Where phase fault stability and accurate time grading is not required, class 10 P and 15 P current transformers may be used. The product of rated burden and rated accuracy limit factor should approach 150, provided earth fault relay setting is not less than 20 per cent of rated secondary current of associated CT class 5 P CT's are preferred where accurate time grading and stability are desired.

35.4. BURDEN ON CT

Impedance of secondary circuit expressed in ohms and power factor. It can be expressed as apparent power and rated secondary current at specified power factor. This power factor is not the power factor of the secondary load.

The circuit connected to the secondary winding is termed as 'burden' of the current transformer. If the term 'load' is used, it refers to the primary current magnitude. Burden is expressed preferably in terms of impedance of the circuit connected to the secondary and its resistance and reactance. The British method is to specify the burden on the CT in volt-amperes at rated secondary current at specified power factor.

Thus we may express the burden in the following two forms, e.g., 0.5 ohm impedance or 12.5 volt-amperes at 5 amperes. Let rated burden be P volt-amperes at rated secondary current I_s , amperes. Then, the ohmic impedance of the burden Z_b can be calculated as follows :

$$Z_b = \frac{P}{I_s^2} \text{ ohms}$$

If burden power factor is $\cos \phi$, $P = \text{VA Burden}$

$$R_b = Z_b \cos \phi \text{ ohms}$$

$$X_b = \sqrt{Z_b^2 - R_b^2} \text{ ohms.}$$

Example 35.1. Calculate the VA output required for a C.T. of 5 A rated secondary current when burden consists of relay requiring 10 VA at 5 A plus loop lead resistance 0.1 ohm. Suggest choice of CT.

Solution.

Volt ampere required to compensate loop lead resistance

$$= I^2 R = 5^2 \times 0.1 = 2.5 \text{ VA}$$

Relay requires 10 VA
Hence total VA output required
= 10 + 2.5 = 12.5

Hence a CT of rating 15 VA and secondary current 5 A may be used.

The burden on a protective current transformer comprises the individual burdens of associated relays, trip coils, connecting leads etc. The total burden is calculated by addition of component burdens as explained in Example 35.1. When individual burdens are expressed in the ohmic value the burdens are converted into VA burdens at rated secondary current. When VA burdens are referred to certain base VA, they should be converted to a common base VA.

Although usual practice is to add the component burdens arithmetically it is more accurate to add resistances and reactances separately, and then calculate impedance.

The impedance of relay coil changes with current setting Impedance decreases with increase in current above rated current.

When the relay is set to operate at current different from the rated secondary current of CT, the effective burden of the relay is calculated as follows :

$$P_e = P_r \left(\frac{I_s}{I_r} \right)^2$$

where, P_e = effective VA burden caused by the relay.

$P_r = V_b$ burden of relay at its current setting.

I_s = rated secondary current of CT.

I_r = current setting of relay.

The following aspects should be noted :

- Impedance of relays, coil, etc., changes with current setting.
- Impedance of relays, trip coils, etc., decreases with increase in current beyond current setting.
- Impedance of electromechanical relay depends upon the position armature.

The values of power consumption of relays, trip coil etc., are given by their manufacturer.

After calculating the total burden on the CT is described above, the CT of suitable burden should be selected.

It is uneconomical to select a CT having a VA output which is very much in excess of the burden. The CT becomes unduly large.

When the nearest standard VA rating is slightly less than the calculated burden, the former may be adopted after consulting the manufacturer.

Example 35.2. The rated secondary current of a current transformer is 5 A.

The plug setting of a relay is 2.5 A. The power consumption of the relay at the 2.5 A plug setting is 2 VA. Calculate the effective VA burden on the current transformer.

Solution.

$$P_e = P_r \left(\frac{I_s}{I_r} \right)^2$$

where P_r = VA burden of relay at given setting.

P_e = Effective VA burden on the CT.

I_s = Rated secondary current of CT.

I_r = Current setting of the relay.

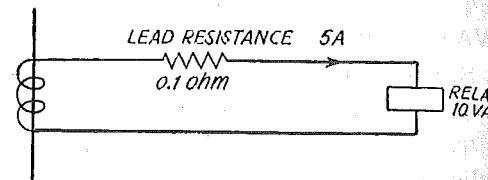

Fig. Example 35.1.

In the given problem, P_e is to be determined

$$P_e = P_r \left(\frac{I_s}{I_r} \right)^2 = 2 \left(\frac{5}{2.5} \right)^2 = 2 \times 4 = 8 \text{ VA. Ans.}$$

The choice of rated VA output of CT should be nearest to that computed as above. Too much margin between calculated and selected values makes the choice either uneconomical or inadequate. Nearest standard VA rating should be selected. CT manufacturer may be consulted.

35.5. VECTOR DIAGRAM OF CT

Symbols : (Ref. Fig. 35.2)

K_n = normal ratio, $\frac{\text{Rated primary current}}{\text{Rated secondary current}}$

K_T = turns ratio, $\frac{\text{Secondary turns}}{\text{Primary turns}}$

K_C = actual current ratio, $\frac{\text{Actual primary current}}{\text{Actual secondary current}}$

I_P = primary current

I_S = secondary current

I_0 = exciting current

I_m = magnetizing component of I_0 , in phase with ϕ , responsible for setting flux ϕ

I_e = component of I_0 , in quadrature with ϕ , responsible to cater for eddy current and hysteresis loss in core

ϕ = main core flux

α = angle between I_0 and ϕ

γ = angle of burden

β = phase angle between primary current and reversed secondary current.

The primary winding of current transformer has a few turns and low impedance. The primary is connected in series with main circuit. The current in main circuit flows through primary. The primary current does not depend on the secondary current. The voltage drop in primary winding of current transformer is negligibly low due to its low impedance.

The secondary of current transformer is connected to a low impedance burden such as relay coil, ammeter current coil. In absence of such a coil, the secondary is kept short circuited. Secondary is not left open for reason discussed later.

Ref. Fig. 35.2. The primary current I_P produces magnetic flux ϕ in the core which induces e.m.f. E_s in secondary. E_s is at 90° behind flux ϕ .

Secondary voltage V_s is given by,

$$V_s = E_s - I_s (Z_s + Z_b) \quad \dots(1)$$

where V_s = Secondary voltage

Z_s = Secondary impedance

Z_b = Burden.

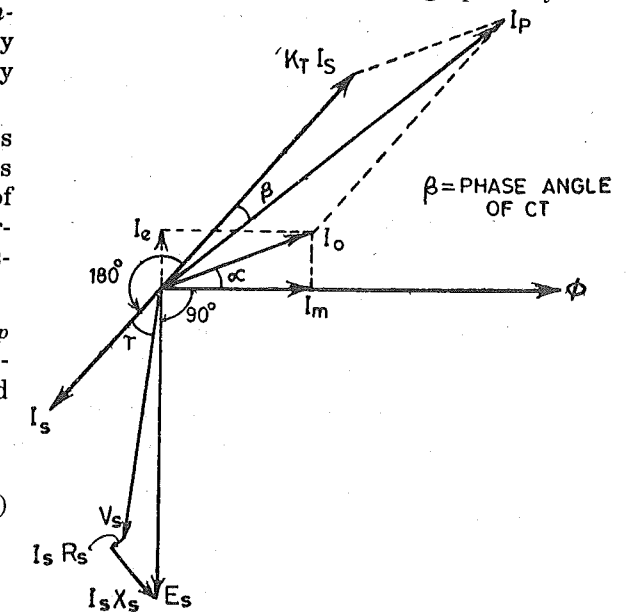

Fig. 35.2. Vector Diagram of VT.

The primary current I_p is given by,

$$I_p = I_o + K_T I_s \quad \dots(2)$$

where, I_o is exciting current required for setting magnetic flux ϕ in the core and to cater for iron losses in core. From Eq. (2), it can be seen that, for ideal transformer,

$$\frac{I_p}{I_s} = K_T \dots \text{if } I_o = 0.$$

However, exciting current I_o introduces the error and

$$\frac{I_p}{I_s} \neq K_T$$

This error is called current ratio error.

Secondly, ideal transformer the secondary current vector when reversed should be in phase with primary current vector. However, from vector diagram it can be seen that, due to exciting current I_o , the reversed secondary current vector leads primary current vector by angle β . This angle is called phase angle error of CT and is expressed in degrees and minutes.

Let us see what happens with increase in burden Z_b .

The secondary e.m.f. E_s is given by equation :

$$E_s \propto f K_n \cdot A \cdot B \quad \dots(3)$$

where f = Frequency ; K_n = Turns ratio

A = Area of core ; B = Flux density in core

$$E_s = V_s + I_s (Z_s + Z_b) \quad \dots(1)$$

For zero burden i.e. short circuited secondary, secondary current I_s (determined by I_s/K_T) produces less drop and E_s is nearly equal to V_s in magnitude and phase. The flux density B is determined by Eq. (3).

If the impedance of the burden increases, the second term on right-hand side of Eq. (1) increase. Thereby E_s increases. To increase this e.m.f. the flux in core increases as indicated in Eq. (3). Thus, higher impedance of burden leads to more flux in core and, therefore, increased exciting currents and increased error.

If secondary is open left circuited (by mistake), the secondary current is reduce to zero. The secondary voltage V_s becomes equal to induced e.m.f. E_s . E_s increase significantly as turns ratio K_n is high and flux density B increases due to absence of any reverse flux. From the above analysis, following conclusions can be drawn :

1. The exciting current I_o introduces ratio error and phase error in CT's. The phase angle error is caused mainly by magnetizing component I_m of I_c and ratio error by exciting component I_s . (Phase angle error is important in directional relays).

2. The exciting current I_o depends upon primary ampere-turns ; magnetic properties of core material, reluctance of core cross-section and length of core.

For good design of CT, the reluctance of core should be low. For this the core should be of smaller lengths and increased cross-sectional area. The material of core should be of high permeability, low loss, small retentivity, high saturation limit.

3. The burden on the CT secondary (Z_b) should be within specified limits. Higher burden results in higher ratio error.

4. Open circuited CT secondary results in very high secondary voltage and saturation of core, and possibly permanent damage to CT.

35.6. MAGNETISATION CURVE OF CT

Fig. 35.3 shows the excitation characteristic curve of a typical oriented electrical steel. The excitation curve may be sub-divided into four main regions— (i) from origin to ankle point (ii) from ankle point to knee (iii) knee region (iv) saturation region. Knee point is defined as where a 10% increase in flux density causes 50% increase in exciting ampere-turns. Protective current transformer generally operates over-working range of flux density extending from the ankle point to the knee-region or above, while the measuring current transformer has the flux density in the region of ankle-point only.

Prior to saturation, the flux density in core is proportional to ampere-turns. On reaching saturation, magnetising inductance becomes low and the total primary current is utilized in exciting the core alone and, therefore, the secondary output of CT disappears. The saturation continues till the primary transient current is reduced below saturation level. On entry in saturation zone, the CT behaves as open circuited.

It is difficult to avoid saturation during short circuit condition. The effect of saturation, is the reduced output, hence reduced speed of over-current relays. In differential relays, the saturation disturbs the balance and the stability of protection is affected.

Current transformer saturation curve is generally plotted in secondary volts vs. exciting current measured in secondary. For the required magnitude of secondary voltage, the degree of saturation can be seen from the curve and is also indicated by magnitude of exciting current to produce this voltage [Fig. 35.1 (b)].

For any transformer, the a.c. performance can be determined by this formula

$$E_s = 4.44 f N A \cdot B_{max} \text{ volts} \\ = I_s (Z_b + Z_s + Z_l) \text{ volts.}$$

where, E_s = r.m.s. secondary induced voltage, volts

N = Number of secondary turns

f = frequency

A = Cross sectional area of core, m^2

B_{max} = maximum flux density Tesla, ($1 T = 1 Wb/m^2$)

Z_b = external burden

Z_s = secondary burden

Z_l = connecting lead burden.

while calculating CT performance, E_s is determined. I_s is calculated from known fault current and choice of CT ratio. I_s multiplied by total burden gives E_s .

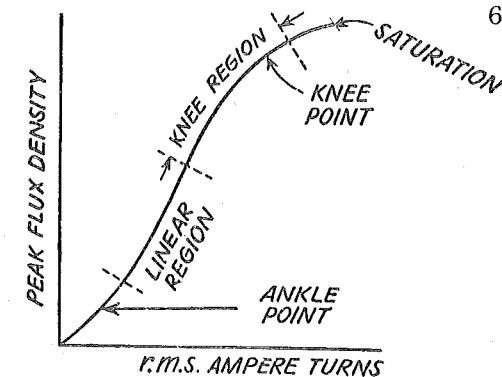

Fig. 35.3. (a) Magnetisation curve—Secondary AT vs. peak flux density.

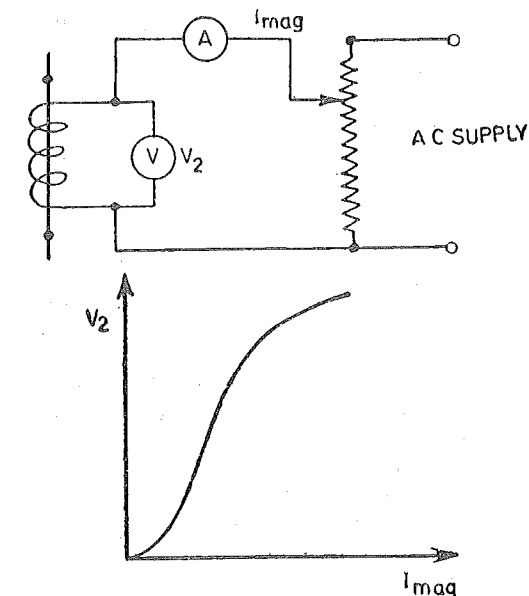

Fig. 35.3. (b) Experiment for Magnetization Characteristic of CT.

Saturation is checked as follows :

Example 35.3. A 2000/5 Ampere, silicon steel CT has 28.45 cm² cross-section and secondary resistance is 0.31 ohm. The maximum primary current for CT is 40,000 amp. at 50 Hz. Relay burden including secondary leads is 2 ohms. Will the core saturate ?

Solution. Primary current = 40,000 A Ratio $N = 400$

$$\text{Secondary current} = I_s = \frac{40,000}{400} = 100 \text{ Amp.}$$

$$E_s = 100 (2 + 0.31) = 231$$

$$E_s = 4.44 fNA B_{max}$$

$$= 4.44 \times 50 \times 400 \times 28.45 \times 10^{-4} \times B_{max}$$

$$231 = 252.63 \times B_{max}$$

$$B_{max} = 0.914 \text{ Wb, peak} = 0.7 \text{ Wb, rms}$$

From B - H curve material, the saturation for this flux density is checked.

35.7. OPEN CIRCUITED SECONDARY OF CT

An important aspect in CT operation is, the voltage appearing across open circuited secondary. Normal voltage across secondary of a 15 VA CT with current of 5A, secondary voltage is 15/5 = 3V.

However, if by mistake, secondary is open circuited, the voltage across the secondary rises to a high value. The peak value may reach some kilovolts. Open circuiting of secondaries results in zero secondary current, hence reduced back e.m.f. The working flux ϕ increases and core gets saturated. The secondary e.m.f. increases due to increased flux.

The primary gets overheated and the core also gets overheated. Voltages are induced in the secondary by electro-magnetic induction. The peak value of the secondary voltage on open circuit may be several times the r.m.s. value since the core is saturated and waveform of voltage is distorted. This may cause danger to personnel working on secondary side. Therefore, when primary current is flowing, secondary should never be disconnected. In bus zone protection, a non-linear resistor may be connected across secondary to limit the peak voltage to safe value.

35.8. POLARITY OF CT AND CONNECTIONS

Polarity gives the relative instantaneous directions of currents in the primary and secondary leads. According to B.S. 3938 the polarity of CT is marked.

P_1 and P_2 : Primary Terminals

S_1 and S_2 : Secondary Terminals

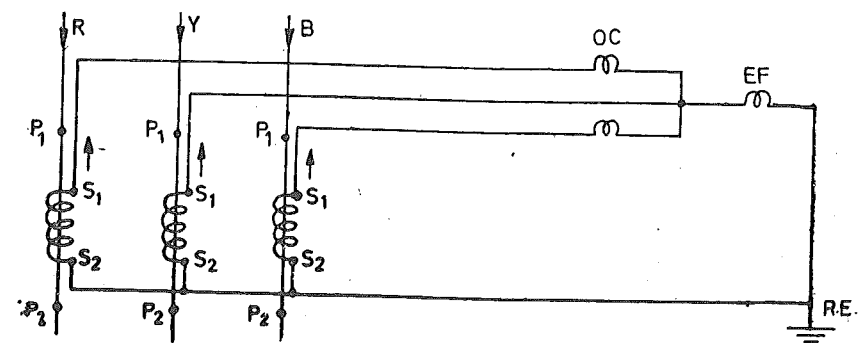
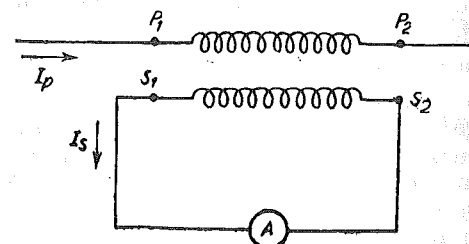

Fig. 35.4. (b) Polarity of CT, for OC and EF protection.



If instantaneous current flows from P_1 to P_2 as marked by the arrow, the instantaneous current will flow from S_1 to S_2 through ammeter as shown by arrow I_s .

Fig. 35.4. (a) Polarity of a CT.

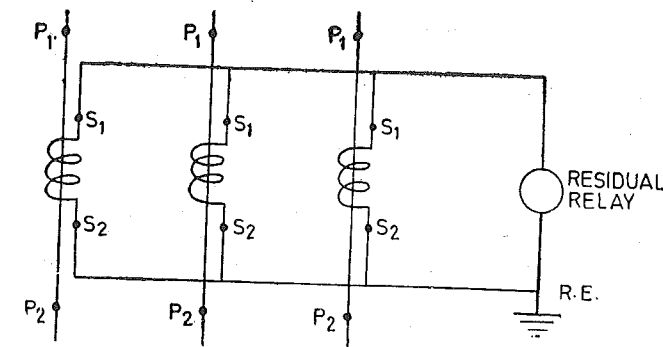

Fig. 35.4. (c) Polarity of CT for EF protection, by residual relay.

Reference Earth (R.E.)

The star point of secondary star is usually earthed for getting stable neutral for protection, measurement and control circuits. The earthing is at only one point as shown in Fig. 35.4 (b) and (c).

Separate CTs are provided for protection, current measurement, watt-hour meter, VAR meter, control circuits. CTs may be separately mounted in outdoor yards or in bushing-turrets or in metalclad switchgear.

35.9. SELECTION OF CURRENT TRANSFORMERS OF PROTECTION RATINGS

(a) **The rated primary current** should be selected from standard values. The value should be so chosen that it is suitable for all normal currents and permissible overload currents in the primary circuit.

Current transformer operating a high-set instantaneous overcurrent relay may be selected for higher rated primary current thereby the required accuracy limit may be reduced.

Referring values of rated primary currents : 0.5 — 1 — 2.5 — 5 — 10 — 12.5 — 15 — 20 — 25 — 30 — 40 — 50 — 60 — 75 — 100 — 125 — 150 — 200 — 250 — 300 — 400 — 500 — 600 — 750 — 800 — 1000 — 1250 — 3000 — 4000 — 5000 — 6000 — 7500 — 10000 Amperes.

Reference values of rated secondary currents :

1 — 2 — 5 Amperes.

Reference values of Rated output :

2.5 — 5 — 7.5 — 10 — 15 — 30 VA and above.

(b) **Rated short time current and its duration**, example : 750 A for 0.5 sec., 525A for 1 sec., 300 A for 3 sec.

(c) **Rated output**, the choice depends on connected load. It is desirable to select rated output near the calculated total burden but not less than the same. Considerable excess rated output will make the choice of CT uneconomical.

(d) **Accuracy class**, for protection purposes :

(i) **Instantaneous overcurrent relays** : Class 15 P.

(ii) **IDMT relays** : Class 10 P where discrimination is important. Class 15 P where discrimination is not important.

(iii) Where phase fault stability and accurate time grading is not required : Class 10 P, 15 P.

(iv) Where accuracy, phase fault stability and accurate time grading is desired : Class 5 P.

(Refer : "Application guide for current transformer" IS : 4201. Revised Reprint 1973).

(e) **Insulation level.** The insulation level should be coordination with other system apparatus. Standard levels are given IS : 2705 Part I —1964. The following aspects need consideration :

- Highest system voltage
- System of earthing
- Degree of exposure to overvoltage.

The quality of current transformers required generally varies with the type of relay application, better quality transformers are desirable. These tend to reduce application problems, provide less hazards in operation is that rally promote better relaying. The most critical application is that of the differential schemes where the performance of all the current transformers should match. In such schemes the relay performance is a function of the accuracy of reproduction not only at load currents, but also at all fault currents.

Some differences can be taken care of in the relays. In general, for transmission line protection, the performance of the current transformer is not as critical. They should reproduce reasonably faithfully for faults near the remote terminal or at a balance point where co-ordination or measurement is being made. For the heavy close in faults, the current transformer may saturate, but in that case, the magnitude of fault current, usually is not as important. For example, an induction overcurrent relay would be operating on the part of the curve for a heavy close in fault. Therefore, it becomes relatively unimportant whether the current transformer current is accurate as the timing is essentially the same. The same is true for instantaneous of distance type relaying operating for a heavy internal fault well inside the cut-off or balance point. In all cases the current transformer should provide sufficient current during saturation to operate the relay positively.

35.10.1. CT'S FOR CIRCULATING CURRENT DIFFERENTIAL PROTECTION

In earlier chapters, the principle of circulating current, differential protection was given. Let us briefly study the requirements of CT's. For through faults (External faults or faults beyond the protected zones) the relay should not operate. The relay should be "stable" during steady state and transient state for through faults.

- Let I_p = rated primary current.
 I_s = rated secondary current.
 I_a = nominal relay setting.

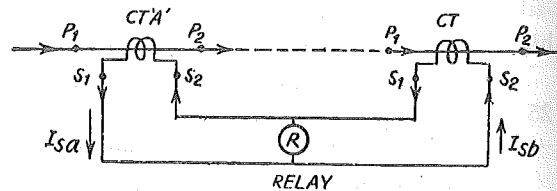
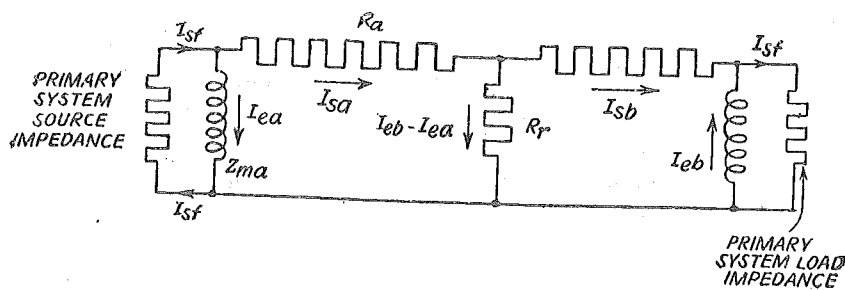

Fig. 35.5. (a) Basic circuit of circulating current protection.



- R_a = resistance of secondary of CT 'A'. Plus resistance of pilot leads
 R_b = resistance of secondary of CT 'B'. Plus resistance of pilot leads
 I_{if} = secondary current for through fault
 Z_{ma}, Z_{mb} = excitation impedance of CT's.

Fig. 35.5. (b) Equivalent circuit when R_p is small.

$$= \frac{XI_s}{100}$$

where X = percentage setting of relay

n = number of times rated primary current upto which stability is desired.

I_{sh}
 I_{sa} } = actual secondary current during through fault condition

R_a = resistance of secondary of CT 'A' plus pilots.

R_b = same for CT 'B'

$$E_a = I_{sa} R_a + R_r (I_{sa} - I_{sb})$$

$$E_b = I_{sb} R_b + R_r (I_{sb} - I_{sa})$$

neglecting relay resistance R_r ,

$$E_a = I_{sa} R_a$$

and

$$E_b = I_{sb} R_b$$

From excitation curve Fig. 35.6 corresponding excitation currents I_{ea} and I_{eb} , are determined

$$\frac{nI_p}{K_t} = I_{sa} + I_{ea} = I_{ea} + I_{sb}$$

where K_r = turns ratio so that current

tending to operate relay I_{so} is given by

$$I_{ro} = I_{sa} - I_{sb}$$

$$= \left(\frac{nI_p}{K_t} - I_{ea} \right) - \left(\frac{nI_p}{K_t} - I_{eb} \right) = I_{eb} - I_{ea}$$

where I_{ro} is the current which tries to operate the relay.

Let I_r be the pick-up current, then for $I_{ro} > I_r$ relay operates and $I_{ro} < I_r$ relay does not operate

Hence for stability $I_{eb} - I_{ea} < I_r$

For time relays such as induction type, the transient response is not important because of the slow operation of the relay.

Procedure of calculating ratio error. The procedure is explained here by taking an example.

Example 35.4. Data. Current transformer of nominal rated 50/5 A.

Secondary winding resistance 0.1 ohm. Burden connected to secondary ;

0.4 ohms at primary current 1000 A and saturation factor 20.

Excitation curve as in Fig. 35.7. To calculate ratio error of the CT.

Solution. Secondary circuit impedance is the sum of (burden + secondary impedance), i.e. $0.1 + 0.4 = 0.5$ ohm. Draw an impedance line AXY having slope of 0.5 ohm.

Primary current 1000 A, secondary current (nominal) $\frac{1000}{10} = 100$ A. Point A corresponds to

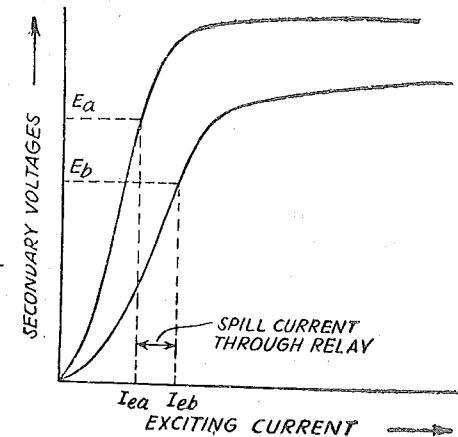

Fig. 35.6. Magnetisation curves of CTs in Fig. 35.5.

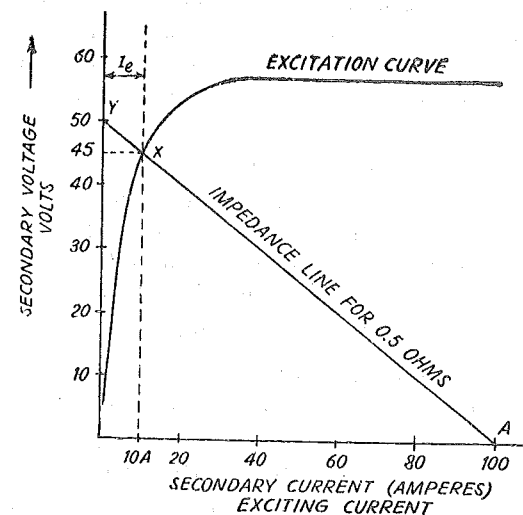

Fig. 35.7. CT excitation curve with impedance line.

secondary current 100 Amperes, primary current $100 \times \frac{5}{50} = 10$ A.

Excitation current I_e is given by the intersection of impedance line AY with excitation curve. From the graph $I_e = 10$ A, secondary induced e.m.f. = 45 V.

Assuming that exciting current oppose each other, we get secondary current value equal to

$$100 - 10 = 90 \text{ A.}$$

$$\% \text{ R.E.} = \left(\frac{K_n I_s - I_p}{I_p} \right) \times 100$$

$$\% \text{ R.E. at } 1000 \text{ A} = \frac{(10 \times 90 - 1000)}{1000} = -10\%.$$

In differential protection, the balance between secondary currents from different phase circuits should be maintained within close tolerance. Hence ratio error should be limited during through faults on all the phases. The CT's should be designed and selected such that the stability is not lost during transient and subtransient state of through unbalanced fault. The CT cores get saturated due to d.c. component of short-circuit current super imposed on a.c. component. To avoid this tendency, the CT's selected for differential protection should have such normal current rating that I_{sh}/I_p is not very high, where I_{sh} is maximum through fault current in primary and I_p is rated primary current. In other words, the turns ratio K_n should be sufficiently high. (I_p high)

The difficulties arising due to CT saturation and unbalance is solved by Biased Differential Relays or High Impedance Differential Relays.

35.10.2. CT's for Overcurrent Phase Fault Protection

While selecting CT's for overcurrent phase fault protection by IDMT relays, it should be ensured that CT's are so selected that they do not saturate upto at least 20 times current setting of relay. This is achieved by selecting CT of low burden and by selecting CT ratio of appropriate high value. High ratio CT will have high rated primary current and would saturate at higher value of short-circuit current.

For graded time lag overcurrent protection, it is practice to employ high ratio CT's in some location and low ratio CT's on other locations.

The low ratio CT's are likely to get saturated for fault currents and high ratio CT's are not.

Saturation of CT core gives rise so predominant third harmonic current in secondary current. The effect of this harmonic on induction disc relays is to increase the time of operation. Thus during fault conditions, the relay connected to low ratio CT's are likely to take more operating time than to high ratio CT's. Hence discrimination based on graded time lag is not satisfactorily achieved.

35.11. CT'S FOR OTHER PROTECTION SYSTEMS ; CT'S FOR DISTANCE PROTECTION

The current coil of distance relay is connected to CT. Here also the saturation of CT due to fault current causes reduced CT output, hence the operating time of a distance relay is considerably increased. The transient saturation factor (X/R ratio) of the source side should be considered. The CT should be selected such that the saturation is avoided during fault conditions.

CT's for Directional Relays

Phase angle errors are particularly important for CT's used for Directional Relays. The CT's should not saturated for maximum through fault current.

35.12. TYPE OF CONSTRUCTION CT'S

I. Ring type CT or Window type CT. This is the simplest type of CT. The core has three types of popular shapes (1) rectangular (2) oval (3) ring shape.

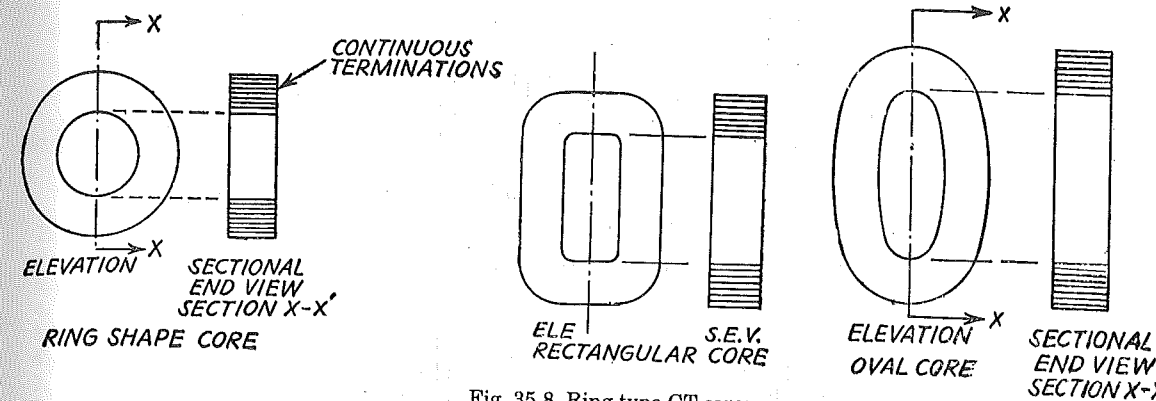

Fig. 35.8. Ring type CT core.

Bar primary current transformer schematic diagram.

P = Primary bar

S = Secondary as in (d)

The core is of a Nickel-Iron Alloy, or grain oriented sheet steel. The core is continuously wound type. Before applying secondary winding, the core is insulated by means of end collars and circumferential wraps.

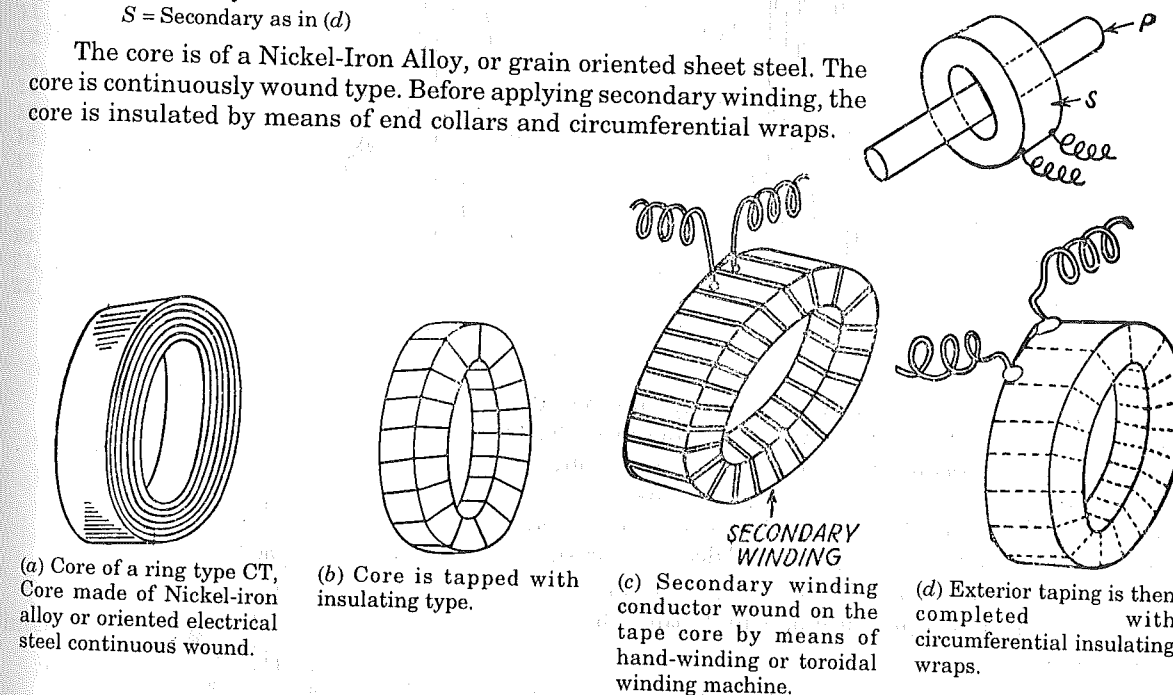

Fig. 35.9. Development of a ring type CT in sequence a-b-c-d.

Recently, the continuously wound cores are available in encapsulated form. Synthetic resins are used as encapsulating material. The material is applied by fluidised beds or electrostatic spraying. The secondary winding conductor is then wound on the insulated core [Fig. 35.9 (c)] in the form of toroidal winding by hand winding or toroidal winding machine.

The secondary winding is then completely wrapped by external tape with or without exterior ring ends and circumferential insulating wraps. [Fig. 35.9 (d)].

35.13. CORE SHAPES FOR MULTITURN WOUND PRIMARY TYPE CT

Cores are either hot rolled silicon-steel stampings or spirally wound strips of cold rolled grain oriented nickel-iron alloy.

Wound primary CT's have primary and secondary windings arranged concentrically. The latter winding is generally the inner one since resistance of this winding should be minimum.

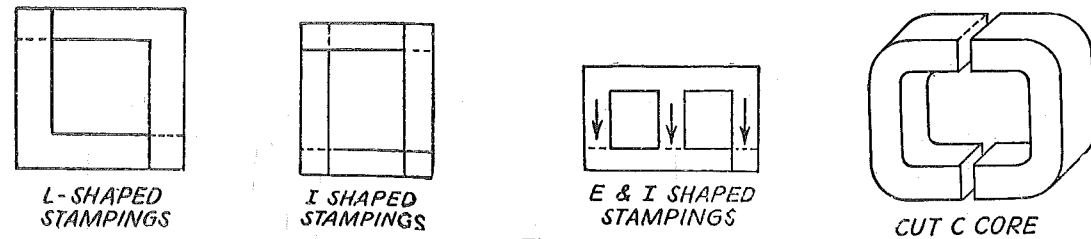

Fig. 35.10

35.14. CURRENT TRANSFORMER FOR HIGH VOLTAGE INSTALLATIONS

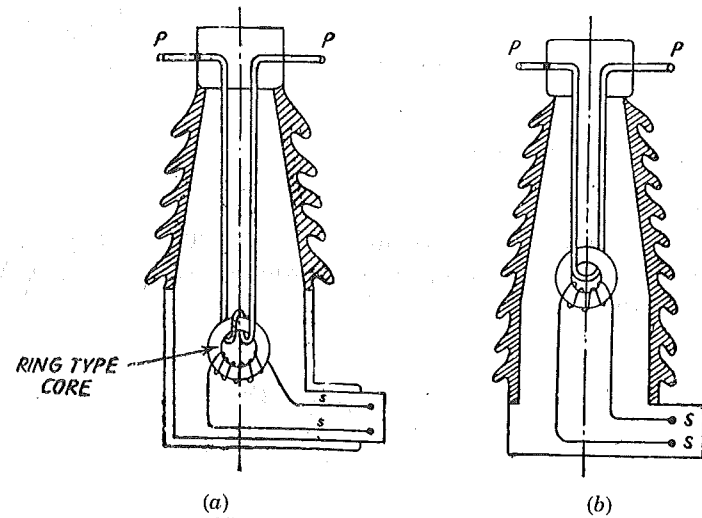

Fig. 35.11. Outdoor High Voltage CT.

Separately mounted post-type CT's are suitable for outdoor service. They are usually installed in the outdoor switch yard. The primary conductor is at high voltage with respect to earth. Hence it is insulated by means of an insulator column filled with dielectric oil. The secondary of CT is just like the ring type CT described earlier.

Dielectric oil is used as an insulating medium. Alternatively SF_6 gas at a pressure of 2 to 3 atmospheres is now being used.

Bushing mounted CTs. Several CTs are conveniently mounted in turrets of power transformers. The primary conductor passes through the center-line. CT cores encircle the primary conductor several cores are provided. Suitable turns ratios are provided for each CT.

35.15. INTERMEDIATE CT

Application

Intermediate current transformers are used ; when the secondary current of a main current transformer is not the same as that for which the devices connected to it are designed to operate ; where two circuits have to be insulated from one another (insulating transformers) ; for

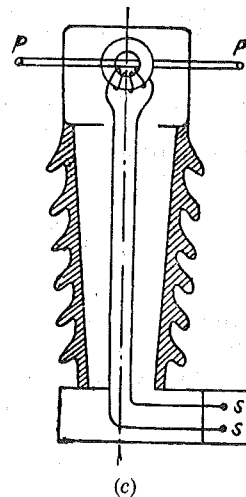

Fig. 35.11. Typical arrangement in out-door HV CT. (Secondary is wound on bushing type insulated core. Primary is mounted in insulator bushing insulation around primary not shown.)

summation or where the current vectors have to be displaced. They are, therefore, used for feeding

- protective devices
- control systems
- measuring systems
- relays in general

In order to satisfy the various requirements, intermediate c.t. of standard design are available in five sizes. The choice is governed in particular by the rated output, the accuracy class and the

1. Primary terminal
2. Secondary terminal box
3. Secondary terminal base
4. Primary coil
5. Primary coil insulation
6. Internal shield
7. External shield
8. Secondary coil
9. Core (circular)
10. Expansion chamber cover
11. Expansion chamber
12. Oil level gauge
13. Porcelain
14. Cover
15. Tank
16. Sealed opening (upper)
17. Sealed opening (lower)
18. Rating plate
19. Pressure relief valve
20. Ground terminal
21. High-voltage lead
22. Secondary terminal board

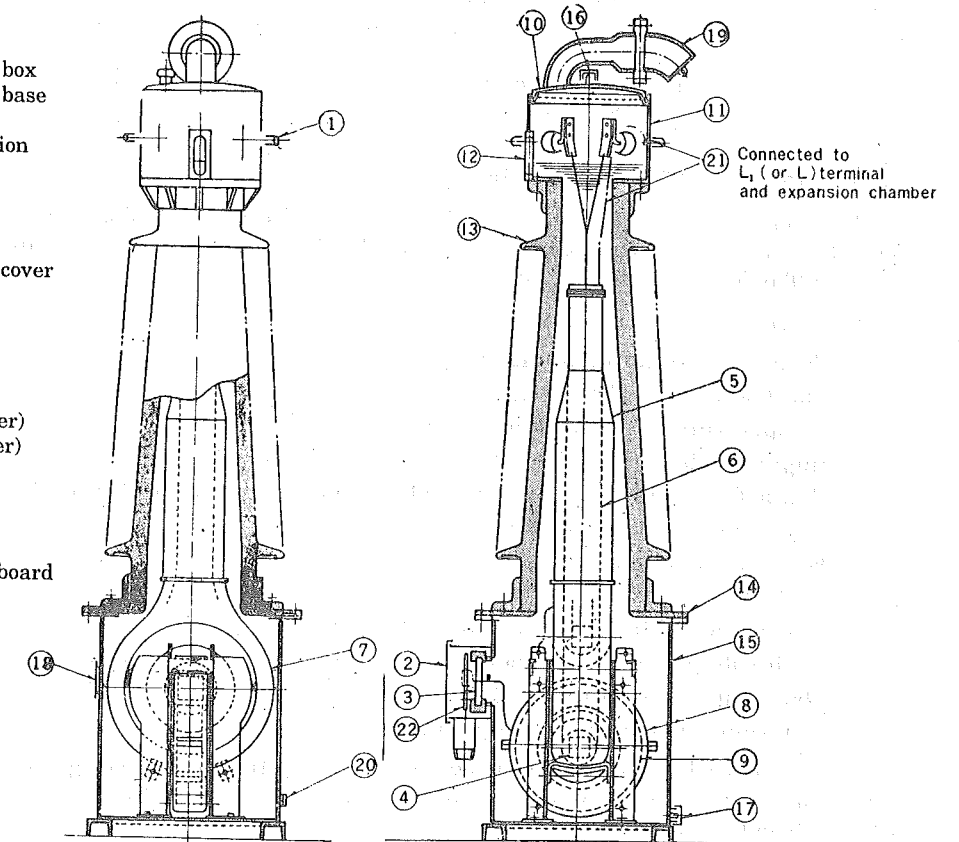

Fig. 35.12. Construction of HV outdoor current transformer shown in Fig. 35.11 (a).

internal consumption.

Design

The standard open-type design has vacuum-impregnated windings and a double-loop core consisting of a pair of high-grade C-cores (small air gap = low magnetizing current = small current error).

The core and coils are held in two vertical frames attached to which is the terminal block with protective wire clip (the terminals may be in one or two rows). Also fixed to the frame is the earthing connection is assumed. Due to their vertical construction the transformers occupy little floor space, which results in a very compact arrangement, especially when they are grouped in threes, which is the most frequent form.

As special design, the transformers can be supplied, with the same fixing holes, potted in resin. In this case the cores and coils are moulded in a metal casing.

Co-ordination of main intermediate CT

When intermediate CT are used it is always important to check whether the rated output of the main CT is large enough to cater for the requirements of the intermediate CT (rated output plus internal consumption). Since the output of a CT is always shown as the rated output, *i.e.* its output at rated current, the individual output figures (leads, internal consumption of the intermediate CT burden) must always be referred to the secondary current rating of the main CT. This is always important if the ratio of the intermediate CT applies under definite working conditions and is not referred to the rated current of the main CT. Conversion of the outputs in accordance with the rated data of the main CT must then take into account the squares of the currents, *i.e.* the sum of the total consumption of the intermediate CT has to be multiplied by the factor :

$$\left(\frac{\text{Secondary current rating of the main CT}}{\text{Rated primary current of the intermediate CT}} \right)^2$$

35.16. TESTING OF CT'S (BRIEF)

Tests on CT's can be classified as Type Tests and Routine Tests. Type tests are conducted on one or first few CT's of each type, to confirm the design and ratings. Routine tests are conducted on each CT before despatch.

Type Tests

- Verification of terminal markings and polarities.
- Short time current test. (Ref. Sec. 11.6).
- Temperature rise test. (Ref. Sec. 10.12.2).
- Impulse voltage test (for outdoor CT's) (Ref. Sec. 13.11).
- Power frequency voltage withstand test on primary. (Ref. Sec. 10.2.6, 12.10)
- Over-voltage interturn test, etc.
- Error Measurement.

Routine Tests

- Verification of terminal markings and polarities.
- High voltage power frequency voltage withstand test on secondary.
- Over-voltage interturn tests.
- Determination of errors and accuracy class.

Furthermore, tests are performed on protective systems by injecting current in primary. Thereby the correctness of polarity connections and stability of protection is ascertained. Some tests on CT's are briefly described below :

(1) **Error Measurements.** The error measurements are carried out in two different methods namely

1. Direct method.
2. Comparison method.

In direct method, two ammeters are used. One is connected to measure the primary current, the other to measure secondary current, as shown in Fig. 35.13.

In comparison method a sub-standard CT is taken, whose error is known. The CT under test is compared with the sub-standard CT. There are several methods based on comparison principle. These are not given here.

Specially designed test equipment is available for testing CT's.

(2) **Turns Ratio Tests.** The usual method is to measure magnitudes of primary and secondary currents near rated secondary current with a low value of secondary burden.

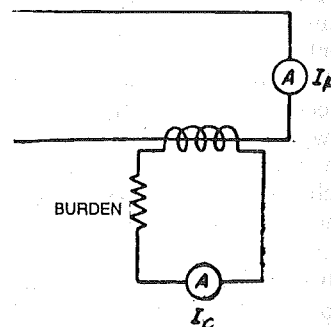

Fig. 35.13. Direct testing of CT.

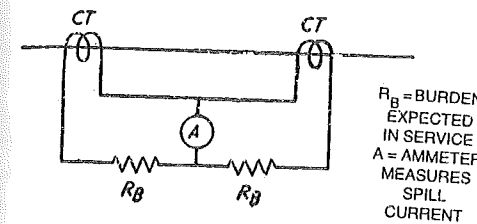

Fig. 35.13. Testing for differential protection.

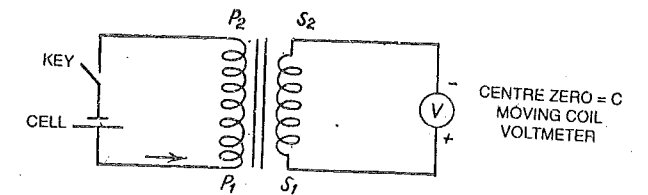

Fig. 35.14. Polarity test.

3. **Exciting Currents.** Exciting current is measured for several secondary e.m.f.s. This is accomplished by applying appropriate voltage to the secondary winding, measuring the current taken by secondary winding, the primary and other windings being open circuited.

4. **Current transformers for balanced differential protective schemes.** The CT's are connected in the test circuit. The spill current is measured for through faults.

5. **Polarity Test.** If at any instant, current is entering the primary from P_1 the current should leave secondary from terminal marked S_1 . A set-up shown in the figure can show whether the polarity markings are correct or not. When the key is pressed, current enters the primary through terminal P_1 , the voltmeter connected as shown, should read positive.

6. **Insulation Tests.** These are conducted according to B.S. 3938 (1965). Specified power frequency voltages are applied to primary for one minute. Impulse tests are conducted on high voltage current transformers.

For secondary circuit test, voltage of 2 kV, 50 Hz is applied for one minute between secondary terminals and ground.

7. **Overvoltage Interturn Test.** In this test the secondary winding is open circuited. Rated frequency, rated primary current is flowed through primary for about one minute. The secondary winding is then checked to see if the insulation has passed the test.

35.17. TRANSIENT BEHAVIOUR OF CT'S

The measuring times of protective relays of today are reduced to the transient state. Hence full attention must be paid to the transient behaviour of the instrument transformers for protective relays.

In current transformers of conventional design saturation of the cores within a few milliseconds is possible due to d.c. components of the short circuit current, during which their secondary current is fully distorted. In order to prevent this, the current transformer cores must be greatly enlarged or air-gaps should be introduced in cores.

The necessary increase is impractical with an iron core of CT's, whereas the use of air gaps limits the physical dimensions to reasonable values.

The short circuit current has d.c. component and a.c. component (Ch. 3). The extreme case is that of a fully displaced short circuit current with ohmic load on secondary side. Primary current can be represented by the equation :

$$i_1 = \bar{i}_2 (\cos \omega t - e^{-t/T})$$

where i_1 = primary current, max. value

T = time constant of system

t = instantaneous value of primary current.

The d.c. component $\bar{i}_2 e^{-t/T}$ causes d.c. magnetic flux density $B_{d.c.}$ the a.c. component $i_1 \cos \omega t$ causes magnetic flux density $B_{a.v.}$

$$\frac{B_{d.c.}}{B_{a.c.}} = \frac{\omega}{T - Tw} (e^{-t/Tw} - e^{-t/T})$$

where

$$T \neq Tw$$

and

$$\frac{B_{d.c.}}{b_{a.c.}} = \omega \cdot te^{-t/T}$$

where

$$T = Tw$$

Tw being time constant of instrument transformer formed by inductance of main CT and total burden. Taking T as 50 ms and several values of Tw between 1000 and 2000 ms it is observed that d.c. component causes very high flux densities during transient period. This again is superimposed on a.c. component.

The conventional CT core saturates during transient condition. The result being, high speed relays are delayed in operation (Ref. Sec. 55.10.2).

Choosing the appropriate current transformer design is determined by the protective system requirement. Where the operation of the protective system is not affected by saturation phenomena of the current transformers as, for instance, with plain overcurrent relays, one may keep using the conventional type of current transformers. Where, however, a saturation-free current transformation is important for a correct and rapid working of the system protection, the dimensions of the current transformer core must be greatly increased. The appropriate factors of core section increase for such cases lead, however, to unreasonable core sizes with iron-enclosed cores and high-power systems. Therefore, for such cases cores with air gaps, have been developed. In providing such air gaps the current transformer time constant, T , is reduced since the current main flux density is diminished. Generally, the flux caused by the D.C. component assumes smaller values, if the current transformer time constant is reduced. The maximum flux density value is, only half if the current transformer time constant Tw is reduced from 2000 ms to 100 ms. Hence the core section dimensions can be limited to values which are still realizable. This is especially true with cores having air gaps are residual flux is practically zero and thus each phenomenon begins again with a flux equal to practically zero. The current transformer time constants can be chosen as small as the resulting increase in phase error allows. A phase error of 1% corresponds for instance, to a current transformer time constant of 250 ms, 3% approximately to 100 ms and 5% to about 60 ms : such values may still be admissible in several systems.

The linear core provides a completely new solution to a wide range of protective systems permitting saturation free transformation of transient phenomena with D.C. components of great time constants.

SUMMARY

Protective transformers include current transformers and voltage transformers. The relays are connected in the secondary circuit of protective transformers. The standard secondary voltage of CT's is either 5 A or 1 A. The standard secondary voltage of voltage transformers is 110 V between phases and 63.5 V between phase and neutral.

The construction of CT follows a general pattern in which the primary has a few turns or a bar which is insulated from earth by means of a porcelain. The secondary is wound on a circular core. The primary passes through the orifice of the core.

The 'burden' of protective transformer is specified in volt amperes at rated secondary current at specified power factor.

The accuracy of protective transformer is specified by classification based on limits of ratio error and phase error.

* Ref. : "Transient Behaviour of Current and Voltage Transformers" Dr. Ing. Rudolf Zahorka Courtesy, ASEA, Sweden.

QUESTIONS

1. Describe the construction of current transformers with the help of neat sketches. Sketch the sectional elevation of a current transformer to be used for high voltage circuit, say 110 kV.
2. What is 'Burden' of a CT ? How is it specified ?
Calculate VA output required from a CT of 5 A rated secondary current when the burden consists of relay requiring 10 VA at 5 A plus loop lead resistance of 0.9 ohms.
3. State the specification to be mentioned while selecting a CT.
4. Why the secondary of a CT should not be open circuited ?
5. State the specifications to be mentioned while selecting a potential transformer.
6. Discuss the problem of transient behaviour of the CT's associated with high speed protective relaying.
7. Write short notes on any two :
 - testing of CT
 - summation transformer
 - intermediate CT
 - selection of PT for protective relaying
 - selection of CT for differential protection
 - selection of CT for bus-zone differential protection.
8. Illustrate CT connections for overcurrent protection and earth-fault protection. Indicate polarities clearly.
9. Explain the behaviour of CT's under transient fault condition. What is the effect of CT saturation on.
 - overcurrent protection
 - impedance protection

Voltage Transformers and their Applications

Introduction — Theory of voltage transformers — Specification of VT's — Terms and definitions — Accuracy class of VT's — Burdens on VT's — Connections of VT — Residually connected VT — Electromagnetic voltage transformers — Capacitor voltage transformer — CVT as Coupling capacitor for carrier current applications — Choice of capacitance for CVT — Transient behaviour of CVT — Ferro resonant (FR) in CVT — Testing of voltage transformer — Summary.

36.1. INTRODUCTION

Voltage transformers (potential transformers) are used for measurement and protection. Accordingly, they are either measuring type or protective type voltage transformers. They may be either single phase or three phase units. Voltage transformers are necessary for voltage, directional, distance protection. The primary of voltage transformer is connected to power circuit between phase and ground. The voltampere rating of voltage transformers is smaller as compared with that of power transformer.

There are two types of construction :

- electromagnetic potential transformer, in which primary and secondary are wound on magnetic core like in usual transformer.
- capacitor potential transformer, in which the primary voltage is applied to a series capacitor group. The voltage across one of the capacitors is taken to auxiliary voltage transformer. The secondary of auxiliary voltage transformer is taken for measurement or protection.
- CCVT combines function of coupling capacitor and VT.

36.2. THEORY OF VOLTAGE TRANSFORMERS

Symbols : V_p = primary applied voltage

V_s = secondary output voltage

K_n = nominal ratio $\frac{\text{primary turns}}{\text{secondary turns}}$

K_v = actual voltage ratio, $\frac{\text{primary volts}}{\text{secondary volts}}$

I_p = primary current

I_s = secondary current

θ = phase angle error of VT, angle between V_p and reversed V_s

I_o = exciting current (no load primary current)

I_m = magnetizing component of I_o in phase with flux ϕ , which sets up flux ϕ

I_e = component of I_o in quadrature with ϕ which caters for iron loss, eddy current loss in core.

Z_p = primary impedance

Z_s = secondary impedance

Z_b = impedance of burden

Z_e = impedance of excitation circuit.

Ref. Fig. 36.1 (a) represents a single line reactance diagram of the VT. The secondary quantities can be referred to Primary by multiplying impedances by K_n^2 and voltages by K_n and equivalent diagram can be drawn [Fig. 36.1 (c)]. Fig. 36.1 (d) gives the vector relations.

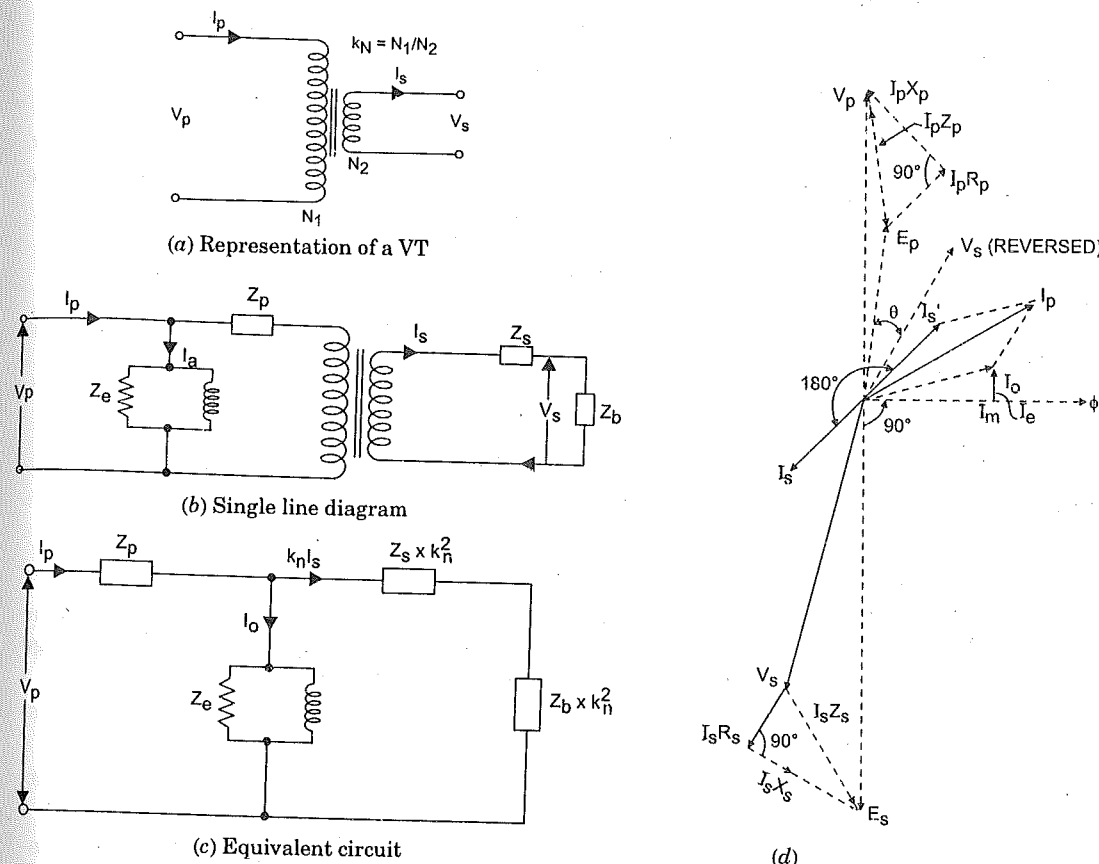

Fig. 36.1. Development of equivalent diagram of a VT.

Primary current I_p is a vector sum of exciting current I_o and equivalent secondary current referred to primary (I_s'). The primary current sets-up flux ϕ . The induced secondary voltage E_s opposes the induced primary voltage E_p .

The secondary voltage is given by :

$$V_s = E_s - I_s (Z_s + Z_b)$$

where $Z_s + Z_b$ is impedance on secondary side.

Primary voltage is given by

$$V_p = E_p + I_p (Z_p).$$

In case of ideal VT

$$I_o = 0$$

$$I_p Z_p = 0$$

$$\frac{V_p}{V_s} = K_n$$

V_p and V_s are 180° apart.

In case of actual VT

The voltage drop in primary impedance and secondary voltage drop introduce errors in ratio.

Hence $V_p \neq K_n V_s$

This error is expressed as a ratio error as follows :

$$\% \text{ Ratio error} = \frac{100 (K_n V_s - V_p)}{V_p}$$

The secondary voltage V_s , when reversed has a phase angle θ with respect to primary voltage. This is mainly due to exciting current I_e of the VT. This angle is called phase angle error of the VT.

36.3. SPECIFICATIONS FOR VOLTAGE TRANSFORMERS

The following aspects should be determined while selecting the current transformer :

1. Rated primary voltage. 2. Rated secondary voltage.
3. Rated burden. 4. Supply frequency.
5. Number of phases. 6. Class of accuracy.
7. Insulation level. Power frequency and impulse voltage withstand.
8. Limits of dimensions, type of construction etc.

36.4. TERMS AND DEFINITIONS

(a) **Rated Primary voltage.** The voltage primary voltage marked on the rating plate of the voltage transformer. The method of connection of primary winding to system and system voltage should be considered while selecting the VT of correct primary voltage rating.

There are several values of standard primary voltages. These have a reference to standard system voltages.

(b) **Rated Transformation Ratio.** The ratio of rated primary voltage to rated secondary voltage.

(c) **Rated Secondary Voltage.** e.g. $100/\sqrt{3} = 63.5$ V or $110/\sqrt{3} = 190$ V. It is the value of secondary voltage marked on the rating plate.

(d) **Residual voltage.** Vector sum of three line to earth voltages, i.e.

$$V_{RD} = V_{RN} + V_{YN} + V_{ZN}$$

(e) **Residual VT.** A three phase VT or a group of 3 single phase residually connected VT's in which residual voltage appears across secondary terminals when three-phase voltages are applied to primary windings.

(f) **Ratio Error.** Percentage ratio error sometimes called percentage voltage error is given in (h) below.

(g) **Voltage factor.** The upper limit of operating voltage (primary) is given by

Rated primary voltage \times Voltage factor, is specified for certain time. e.g., 1.1 continuous, 1.5 for 60 sec., 1.9 for 30 sec.

$$(h) \quad \% \text{R.E.} = \frac{100 (K_n V_s - V_p)}{V_n}$$

where K_n = Nominal ratio

V_s = Secondary voltage

V_p = Primary voltage.

R.E. = Ratio error.

As alternate method describe the ratio is to specify the voltage ratio factor (V.R.F.)

$$\text{V.R.F.} = \frac{K_v}{K_n}$$

$$K_n = \text{Nominal ratio} \frac{V_n}{V_s}$$

$$K_v = \text{Voltage ratio} \frac{V_p}{V_s} \text{ actual.}$$

$$\text{V.R.F.} \approx 1 - \frac{\% \text{R.E.}}{100}$$

36.5. ACCURACY CLASSES AND USES [B.S. 3914 (1965)]

Standard specify the following limits of errors for voltage transformers and protection for measurement.

Table 36.3. Limits and Phase Errors for Voltage Transformers

Accuracy Classes	0.9 to 1.1 times rated primary voltage 0.25 to 1.0 times rated output at 0.8 lag p.f.		Application
	Voltage error % (per cent) (+ or -)	Phase error minutes (minutes) (+ or -)	
0.1	0.1	5	Measurement
0.2	0.2	10	
0.5	0.5	20	
1.00	1.0	40	
3.0	3.00	120	Protection
5.0	5.00	300	
10.0	10.00	—	Residual VT only

Applications of VT's Depending Upon Accuracy Class

Accuracy Classes	Application
0.1	Precision testing in standard laboratories
0.2	Sub-standard instruments in laboratories.
0.5—1	Industrial metering
3.00	Voltmeters
5.00	Under voltage relays, overvoltage relays, other relay where phase angle is not important
10.00	Directional relays where phase angle is important.

Note. (1) Class 3.0 and 5.0 VT's are recommended for protection.
2. Class 5.00 and 10.00 is recommended only in Residual VT's.

36.6. BURDENS ON VOLTAGE TRANSFORMER

Burdens are specified in voltamperes at a rated secondary voltage at a particular power factor. Let rated secondary voltage be V_s . The ohmic impedance of burden be Z_b . Volt-ampere burden = P .

$$Z_b = \frac{V_s^2}{P} \text{ ohms.}$$

Let burden power factor be $\cos \phi$

$$R_b = Z_b \cos \phi$$

$$X_b = Z_b \sin \phi$$

$$Z_b = \sqrt{R_b^2 + X_b^2}$$

The total burden on a VT should be less than the rated burden of VT.

Table 36.4 gives rated burdens of bushing type potential transformer device. The capacitor voltage transformer output is upto about 200 VA. While that of wounded type is upto about 500 VA. The standard values being 10, 25, 50, 75, 100, 150, 200, 500 VA.

Example 36.3. A voltage transformer with rated secondary voltage of 110 V has nominal output of 1 A, lead loop resistance is 0.1 ohm. Calculate the voltampere output of the voltage transformer when the relay takes 0.1 ampere at 110 volts.

Solution. Total voltamperes = Voltamperes for relay + Voltamperes or leads

$$= 110 \times 0.1 + (0.1)^2 \times 0.1 = 11 \text{ VA. Ans.}$$

Table 36.4. Reference Voltage of Burdens on VT's

Rated Voltage KV		Rated Burden Volt-ampere
Phase to phase	Phase to ground	
115	66.4	25
138	9.74	35
161	93	45
230	133	80
287	166	100

Table 36.5

Typical Values of Burdens imposed by different measuring instruments and relays on Voltage Transformers

Voltmeter	5 VA
Voltage coil of Wattmeter	5 VA
Voltage coil of kWh meter	7.5 VA
Voltage coil of Synchroscope	15
Under voltage/over voltage Relay	5 VA
Voltage coils of electromagnetic relays	3—10 VA
Static relays	0.02—0.2 VA

The total burden on a VT is vector sum (r and jX) of component burdens on secondary e.g., burden on a VT for under voltage protection would be the sum of burden of relay coil, pilot wires. The VA rating should be such that the total burden is about 10% less than rated burden, for pick-up condition. If the VT is overloaded beyond its rated burden, the error will increase. The burden of a relay varies for various settings. The VA rating of VT should not be far greater than the burden. Because the accuracy of VT at very low burdens (25% rated burden) is not guaranteed.

36.7. CONNECTIONS OF VT'S

There are three types of connections, V-V, Star-Star and Star Open Delta. (Residually Connected) VT.

1. V.V. Connection

This connection is used only for measurement and usually not for protection. Two VT's are used. Primaries are connected V, secondaries also in V. There is no path for zero sequence voltages arising from earth faults.

2. Star-Star Connections. (Fig. 36.2)

Either three separate transformers or a single three limb transformer are used. Primaries are connected in star, secondaries also connected in star.

Each primary phase winding is connected phase to earth. Voltage of supply circuit is transformed into secondary.

The neutral point of load is connected to neutral point of secondaries. The neutral point of primary is solidly earthed with such connections (Ref. Fig. 36.3).

If primary neutral is not earthed, the zero sequence component of voltages (due to earth fault) cannot flow through primary windings. Hence phase to earth voltages of system which contain zero sequence component do not get truly transformed. Measured voltages are distorted.

Hence the earth fault on the system cannot be sensed on the secondary side of VT.

In voltage restrained overcurrent fault protection (Fig. 36.3), in impedance protection for earth faults, the VT connection should be such that zero sequence component of voltage is reflected on secondary. Hence the neutral of primary should be earthed.

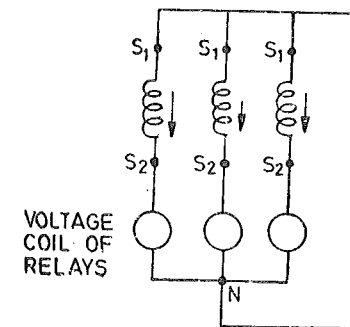
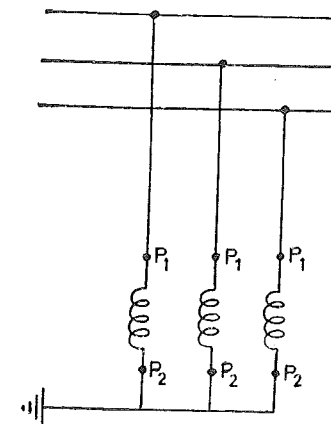

Fig. 36.2. Connection of VT's with star-star connection.

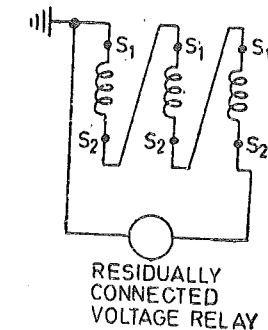
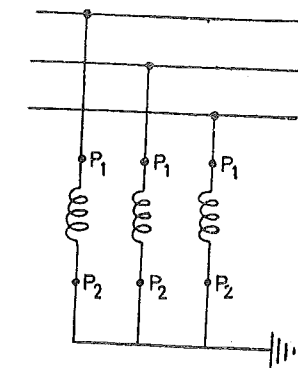

Fig. 36.3. Connection of Residually connected, VT.

When electromagnetic type of VT is used for star-star connections, it should be of 5 limb construction, to provide path for zero sequence component of magnetic flux. The zero sequence component of flux ϕ_0 in three limbs is in one direction. In three limb construction, there is no return path for flux.

In five limbed transformer, the outer two limbs provide a path for zero sequence component of magnetic flux. Thereby the zero sequence voltages are transformed.

36.8. RESIDUALLY CONNECTED VT (ZERO SEQUENCE VOLTAGE FILTER)

The primary windings are connected in star and star point is earthed. The secondaries are connected in series with the load [Fig. 36.3 (a)].

$$V_{SR} + V_{SY} + V_{SB} = 3V_{SO}$$

where, V_{SR}, V_{SY}, V_{SB} = Secondary voltages

V_{SO} = Zero sequence voltage on secondary.

The voltage appearing across broken delta ($3V_{SO}$) is proportional to zero sequence component of voltage on primary.

Under no-earth fault

$$V_{PR} + V_{PY} + V_{PB} = 0$$

$$V_{PO} = 0$$

Hence $V_{SR} + V_{SY} + V_{SB} = 0$

$$V_{SO} = 0$$

(Subscript P for primary, S for secondary, RYB for respective phases and O for zero sequence).

Hence output of residually connected VT secondaries is zero under earth fault condition.

$$V_{PR} + V_{PY} + V_{PB} = 3V_{PO}$$

Hence, $V_{SR} + V_{SY} + V_{SB} = 3V_{SO}$

$$3V_{SO} = \frac{3V_{PO}}{K_n} = V_r$$

V_r = Residual voltage flowing through the load connected across residually connected VT secondary.

K_n = Voltage ratio.

The residually connected VT, the star point of primary must necessarily be earthed.

Residually connected VT is used for supplying :

1. Voltage coil of voltage restrained overcurrent earth fault protection.
2. Restricted earth fault protection.
3. Directional earth fault protection.
4. Distance earth fault protection.
5. Earth-fault alarm relays.

One point on secondary is necessarily earthed for safety. In case the primary comes in contact with secondary.

The residually connected VT may have three single phase units or one three phase five limbed unit.

Accuracy class of residually connected VT is 5.00 or 10.00.

Types of Construction of VT's

1. Electromagnetic Voltage Transformer, oil filled/epoxy resin encapsulated.
2. Capacitor voltage Transformer. (CVT).

36.9. ELECTROMAGNETIC VOLTAGE TRANSFORMER

Potential transformer is similar to a conventional transformer with additional care taken to minimise errors of transformation, and the power transformed is low. The construction of a PT largely depends on the rated primary voltage. For voltage upto 3.3 kV dry type transformers with varnish impregnated taped windings are quite satisfactory. For higher voltages it is a practice to immerse the core and winding in oil. Recently windings are impregnated and encapsulated in syn-

thetic resins. With this development, dry type PT's are available for voltages higher than 3.3 kV. Cast resin insulated PT's are available for voltages upto 66 kV.

The core of a smaller voltage transformer is usually made up of normal T, U, E, I, L shaped laminations when hot rolled steel is employed. For smaller PT's shape of Fig. 36.4 is generally used.

For larger single phase units cut C core is used of oriented sheet steels.

The electromagnetic VT's are either indoor or outdoor. Porcelain enclosure is necessary for outdoor VT's.

The electromagnetic VT for residual connections should have five limbs.

For voltages above 66 kV, electromagnetic PT's are generally in cascade connections. They employ a number of series connected primary coils on separate cores, with coupling coils to link primary coils so as to keep the effective leakage inductance at a low value. Such an arrangement is conveniently housed in a porcelain enclosure. However, capacitor Type PT is more economical. For high speed distance protection, electromagnetic voltage transformer is preferred.

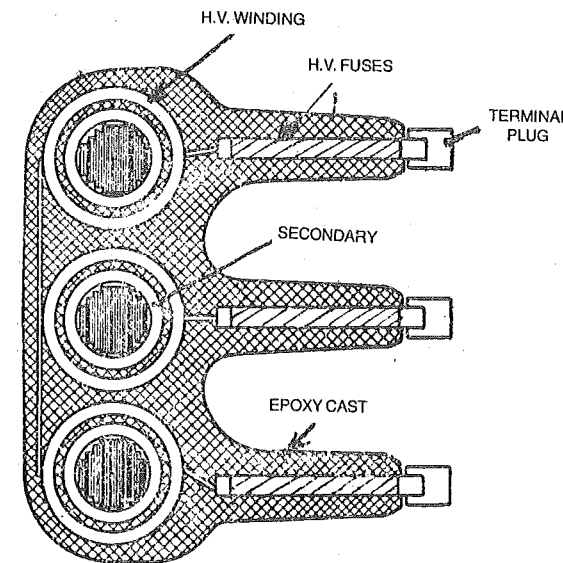

Fig. 36.4. Cross-section of a resin cast VT.

The secondary leads should have low impedance to reduce voltage drop.

36.10. CAPACITOR VOLTAGE TRANSFORMERS (CVT)

Capacitor voltage transformer are used for line voltmeters, synchroscopes, protective relays, tariff meter, etc.

The performance of capacitor voltage transformer is inferior to that of electromagnetic voltage transformer. Its performance is affected by the supply frequency, switching transients, magnitude of connected burden, etc. The capacitor voltage transformer is more economical than an electromagnetic voltage transformer when the nominal system voltage increases above 66 kV.

The carrier current equipment can be connected *via* the capacitor of the Capacitor Voltage Transformers. Thereby there is no need of separate coupling capacitors.

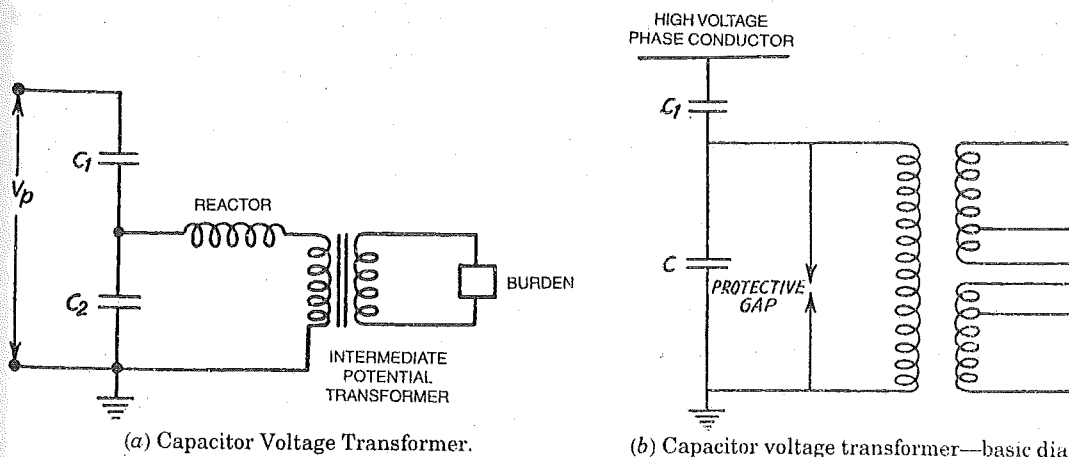

Fig. 36.5.

Capacitor type VT is used for voltages 66 kV and above. At such voltages cost of electromagnetic type VT's tends to be too high. The capacitors connected in series act like potential dividers provided the current taken by the burden is negligible compared with the current passing through the series connected capacitors. However, the burden current becomes relatively larger and ratio error and also phase error is introduced. Compensation is carried out by 'tuning'. The reactor connected in series with the burden is adjusted to such a value that at supply frequency it resonates with the sum of two capacitors. This eliminates the error. The construction of capacitor type VT depends on the form of capacitor voltage divider. Generally, h.v. capacitors are enclosed in a porcelain housing. A large metal sheet box at the base encloses the tuning coil intermediate transformer.

36.10.1. CVT with Stepped Output

When the same CVT is used for various applications, it is likely to be subjected to a variation of burden. The CVT for such applications should have stepped output range. The number of steps and output range depend upon the choice of user and recommendations of manufacturer. The sum of outputs of the steps should be one of the following values :

10, 25, 50, 75, 100, 150, 200, 500 VA.

36.10.2. Protection of Voltage Transformers

- HRC fuses on primary side for VT's rated upto 11 kV.
- HRC fuses on secondary side for overcurrent protection of electromagnetic unit.
- spark gaps or lightning arresters in parallel with intermediate capacitor for overvoltage protection.

36.11. CVT AS COUPLING CAPACITOR FOR CARRIER CURRENT APPLICATIONS

The carrier current equipment is connected to the power line *via* coupling capacitor. The coupling capacitor Voltage Transformer (CCVT) combines the functions of coupling capacitor and Voltage Transformer. Fig. 36.6.

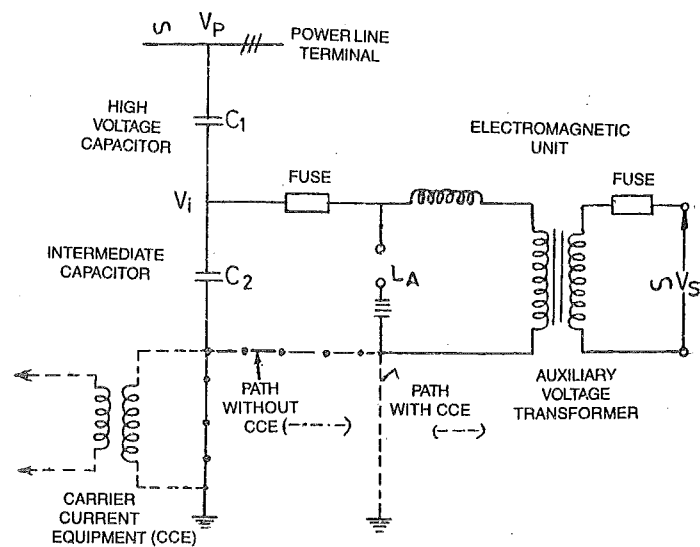

Fig. 36.6. Connection of CVT and carrier current equipment.

36.12. CHOICE OF CAPACITANCE VALUES FOR CVT

The maximum output from a capacitor voltage transformer is governed by the range of frequency over which the accuracy has to be maintained. The change in error with variation of fre-

quency is mainly a change in phase when the burden is of unity power factor. The permissible rated output may be derived from the expression :

$$W = K (C_1 + C_2) V_i^2 \theta_e \quad \dots(36.11)$$

where W = output in VA ;

K = constant depending on frequency, losses, etc. ;

C_1 = capacitance of primary voltage capacitor in farads ;

C_2 = capacitance of intermediate voltage capacitor in farad ;

V_i = intermediate (tapping point) voltage in volts ; and

θ_e = phase angle error change in minutes per Hz.

It is apparent from the above expression that, for a given accuracy over a given frequency range, the rated output is proportional to the total capacitance at a fixed tapping point voltage, but the capacitance required may be reduced to the economic limit by a suitable selection of the intermediate voltage. On the other hand, when the capacitance values are fixed by other considerations, the rated output may depend entirely on the permissible phase-angle error change (θ_e) per Hz.

Consider the single line diagram of a CVT (Fig. 36.7) and its equivalent circuit as referred to primary voltage V_p [Fig. 36.7(b)]. At normal power frequency C and L are in resonance, therefore, offer zero impedance. Therefore, the CVT behaves like conventional VT.

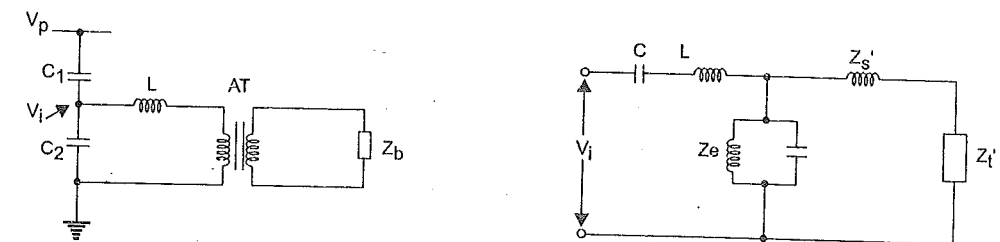

(a) Single line diagram of CVT

(b) Equivalent diagram of (a)

Fig. 36.7. Equivalent diagram of CVT.

However, this resonance is at a particular frequency (50 Hz). At other frequencies, I_C and I_L do not get cancelled and the reactive component present introduces phase angle error in measurement. This error depends on the power factor of burden.

The phase angle error changes with frequency. If reactive voltage across C and L is small compared with V_p , the error introduced is small and change in error with frequency is not excessive.

However, choice of frequency depends upon whether the capacitor is used as a coupling capacitor for carrier channel or not.

(a) The typical values of C_1 is 2000 pf. It offers 1.5 mega-ohms impedance to 50 Hz and 150 ohms to 500 kHz carrier frequency.

(b) The value of C_2 depends upon the required nominal ratio.

$$\frac{V_p}{V_i} = \frac{C_1}{C_2}$$

Suppose V_i is 12 kV and V_p is $132/\sqrt{3} = 75.6$ kV.

$$C_2 = \frac{132}{\sqrt{3}} \times \frac{1}{12} \times 2000 = 1200 \text{ pf.}$$

(c) The output is of the order of 150 VA.

(d) θ_c has a following range :

- 50 minutes for 132 kV, CVT
- 25 minutes for 220 kV, CVT
- 15 minutes for 400 kV, CVT

From Eq. 36.11 large C_1 and C_2 permit higher rated VA output. To reduce cost, the CVT's are designed for larger regulation (variation in secondary voltage) with variation of burden Z_b . VT is provided with taps which should be selected for required value of burden. Alternatively CVT's can be "Full Range Type", without taps and suitable for burdens in a range of 25 to 100% of rated output. Such CVT's would require larger C_1 and C_2 and are costly.

(e) **Effect of Supply Frequency.** CVT's perform within accuracy limits for frequencies of 77 to 103% of rated frequency for protective VT's and 99 to 101% for measuring VT's.

The variation in the primary side power frequency has significant influence on the accuracy of a CVT. Normally a capacitor voltage transformer is turned to achieve the required accuracy at rated frequency (50 Hz). When the operating frequency deviates beyond the reference range of frequency, the accuracy limits are likely to be exceeded. Coincident influential factors are the power factor and the magnitude connected burden. Where accuracy is important as in tariff metering applications. It is desirable to obtain accuracy curves for the capacitor voltage transformer corresponding to the limiting operating frequencies.

These curves (supplied by manufacture of CVT) give the ratio error and phase angle error for various frequencies. The power factor of burdens is also indicated on the same graph.

36.13. TRANSIENT OF BEHAVIOUR OF CVT

The transient performance of CT's discussed in Sec. 35.16 was related to saturation of core due to d.c. and a.c. components in transient over-currents.

The transient performance of CVT's is influenced by transient over-voltages and resulting distortion in secondary voltage waveform, and duration of overvoltage.

When an impulse wave is applied to primary of CVT, oscillations of various frequencies take place and will continue for a duration which depends upon the resistive damping in the equivalent circuit [Fig. 36.7 (b)]. Increased resistance reduces the time constant of transient oscillations. However initial amplitude increases.

For high speed protection, transient oscillations should be minimum. Hence cascade type electromagnetic voltage transformers are preferred. They have a less ratio error even under short-circuit condition.

36.14. FERRO-RESONANCE (FR) IN CVT

(a) **Principle.** Ref. Fig. 36.7. The excitation impedance Z_e and equivalent C of voltage divider may form a resonant circuit which may oscillate at a lower frequency than 50 Hz.

If such a circuit is subjected to a impulse voltage due to switching transient voltage oscillations of variable frequency do occur. These can pass through a range of frequencies due to non-linear nature of inductance of auxiliary VT.

If natural frequency of this circuit is somewhat less than $50/3$; it is possible that the oscillations build-up by taking energy from system. When the variable oscillations reach the natural frequency resonance condition occurs. This causes increased flux density in auxiliary transformer core and thereby bringing the natural frequency to exactly $50/3$.

This results in progressive build-up of third harmonic oscillations which are stabilized for indefinite time. The third harmonic component increases the secondary voltage to 1.2 to 1.5 times rated secondary voltage. The waveform of secondary voltage containing third harmonic is also non-sinusoidal. Hence ferro-resonance should be prevented.

Good design of CVT will not exhibit ferro-resonance for resistive burdens. However, non-linear inductive burdens (such as auxiliary voltage transformers in protective systems) are likely to cause ferro-resonance. Auxiliary VT's should have a large core so as to maintain flux density at a low value (0.2 to 0.4 Wb/m²) to prevent saturation.

(b) **Methods for Minimising FR in CVT.** The ferro-resonance arises due to the interchange of energy between the equivalent capacitance of the voltage divider and the non-linear inductance of the magnetic unit. It results in a severe distortion of the secondary voltage. It can also result in sustained sub-harmonic oscillations. This can be avoided by taking suitable precautions while designing the CVT. Some of the methods are given below.

- Maintaining the working flux density of the electromagnetic units at much lower levels as compared with the conventional voltage transformers (e.g. 0.2 to 0.4 Wb/m² only).
- Greater utilization of the linear position of the magnetisation curve by using strip would cores, thus avoiding local saturation effects.
- Providing an air gap in the magnetic circuit of auxiliary VT to maintain the linearity of magnetising inductance over a wide range of operating conditions.
- Connecting a suitable damping resistance permanently across the secondary.
- Spreading out (deploying) auxiliary tuning and damping networks in the electromagnetic unit. In this case it is necessary that additional precautions are taken to avoid introduction of additional transients in the process of damping ferro-resonance.

(c) Method of Testing FR in CVT

In case of CVT's, it is necessary to check that the ferro-resonance does not occur and the transient oscillations die down quickly after removal of secondary short-circuits.

While testing CVT, the secondary is temporarily shorted. A voltage of 120% rated value is applied to primary. The short-circuit on secondary is suddenly removed. The peak value of secondary voltage is recorded. The peak secondary voltage should not differ from 110% normal value, after 10 Hz. Ferro-resonance should not sustain for more than 2 sec.

36.15. TESTING OF VOLTAGE TRANSFORMER (BRIEF)

(a) **Error Measurements.** The errors are generally measured by comparison method, i.e. comparing the voltage transformer under test with a sub-standard voltage transformer of high accuracy and known errors. Errors are measured for various primary voltages, for rated burdens.

(b) **Core losses.** Measurement of core loss and exciting current are made to check the quality of core material and short-circuits in winding between turns.

(c) **Insulation Tests.** Routine insulation tests are of two kinds, applied and induced overvoltage tests. In applied tests, the primary winding is short-circuited and test voltage is applied between primary winding and earth, for specified time and of specified value.

Induced voltage tests are made to test inter-turn and inter-layer insulation of the windings. The supply is usually applied to the secondary winding at a frequency two to four times normal frequency to prevent core saturation and excessive exciting current. The secondary insulation is tested by applying 50 Hz. 2 kV for one minute type tests on voltage transformer include impulse tests.

(d) **High voltage tests.** Power frequency with stand tests and impulse withstand tests. (Ref. Sec. 12.8, 12.11).

(e) **Polarity Test.** These are similar to the test on CT's (Refer Sec. 35.8).

36.16. APPLICATION OF CAPACITOR TYPE VOLTAGE TRANSFORMER FOR PROTECTIVE RELAYING

The requirements of protective voltage transformers depend upon the application.

1. For capacitor type voltage transformer used for residual connection, accuracy class 10 is generally preferred.

2. In applications of voltage transformers where phase relationship between current and voltage is important, accuracy class 3 is preferred. These applications include directional over-current relaying, reverse power protection, distance protection, etc.

3. In applications, where phase angle is not significant; accuracy class 5 is preferred. Such applications include under-voltage overvoltage, voltage restrained protection.

4. For high speed distance relays, electromagnetic voltage transformers are preferred.

For potential transformer for protection purposes it is a common practice to measure the primary and secondary volts in terms of line-to-line. In other words, 110 volts is generally line-to-line voltage in terms of the secondary. Where relays are line-to-neutral voltage, their coils are generally at $110/\sqrt{3}$, V.

5. Protective relays operate under system fault conditions. As the faults are associated with voltage drops, a protective voltage transformer is required to maintain its accuracy within the specified limits from 5 per cent of the rated voltage to voltage factor time the rated voltage.

6. Capacitor voltage transformers may be of full range or of stepped range design.

7. Composite transformers used for protection and measurement, are normally of full range design. Although adjustment of the ratio and series inductance of the electromagnetic unit is usually necessary to enable capacitors with commercially practical tolerances to be employed, once the adjustment setting to suit a particular set of capacitors has been determined, no further adjustments are necessary in service. Such full range devices may thus be employed in service in the same manner as electromagnetic voltage transformer and power factor corrections for inductive burdens are not necessary.

(8) When same VT is used for both protection and measurement (Dual propose) separate secondary winding may be used. The rated burden of each winding may be separately specified.

(9) Actual VA burden on VT should be about 90% of rated VA burden of VT.

SUMMARY

Voltage transformers are used for protection are generally different from those for metering with reference to their accuracy class. Generally class 3.0, 5.0 is used for voltage transformers connected in star-star and class 10.0 for residually connected VT's.

There are two types of construction : 1. Electromagnetic VT (2) CVT. Electromagnetic VT's are more accurate than CVT's. CVT's are used for voltages above 66 kV.

Transient performance of VT's is important in protection. CVT should not give ferro-resonance and secondary over-voltages. Electromagnetic VT is superior to CVT in this respect.

QUESTIONS

1. Illustrate with clear sketches the following :
 - (a) Connections of VT's in V-V for measurement of voltages.
 - (b) Connections of VT's in star-star for under-voltage/over-voltage protection.
 - (c) Residual connection of VT's.
2. Draw a vector diagram of VT and discuss the causes of ratio error and phase angle error. State the preferred accuracy classes for protective relays.
3. The power consumption of each voltage relay coil used in a over-voltage protection is 5 VA. The lead resistance is 0.1 ohm per lead. There is no other burden. Draw diagram of over-voltage protection for a 132 kV, three phase bus-bar illustrating VT and relay coil connections.
4. Describe the construction of Capacitor Voltage Transformer and discuss the factors affecting the choice of capacitors, auxiliary electromagnetic VT, spark gaps, arrangement of coupling of carrier current equipment.

5. Describe the applications of VT's in the following applications :

- distance protection
- direction earth fault protection.

Illustrate VT connections and CT connections in these.

6. Describe the residual connections of VT. Why a five limb core is essential for each electromagnetic residual VT.

7. Describe the phenomena of ferro-resonance in capacitor voltage transformer and the methods adopted to minimise the same.

8. Fill in the gaps :

(a) Electromagnetic VT is accurate than CVT.

(b) Ratio Error of a VT is given by

(c) In residually connected VT, the three secondaries are connected in

(d) Ferro-resonance occurs in type VT.

(e) There are two categories of VTs. 1 (2)

(f) Ohmic value of burden Z_b is given by the expression $Z_b = \dots\dots$

(g) Accuracy classes recommended for VTs are as follows :

1. Measuring VT

2. Protective VT

3. CVT only

Testing and Maintenance of Protective Relays

Importance of maintenance — Tests — Acceptance tests — commissioning tests — Inspection prior to test — Testing of instantaneous relays — Inverse relay — Differential relays — Distance relays — Restricted earth fault protection, Routine maintenance — Deterioration of relays — Maintenance schedule — Manufacture tests — Electrical tests — Mechanical tests — Environmental tests — Buchholz relay — Equipment for tests.

37.1. IMPORTANCE OF MAINTENANCE AND SETTING

Unlike the rotating machines or other equipment, the protective relays remain standstill and without operation until a fault develops. However, the relay should be vigilant at all times. For reliable service of protective relaying excellent maintenance is a must. Lack of proper maintenance may lead to failure to operate.

Every relay has a provision of setting.

Setting determines pick-up value/time.

Settings of various relays need co-ordination.

37.2. TESTS ON RELAYS

Tests are conducted by the manufacturer at manufacturer's works, and by the user at site during commissioning and periodic maintenance. These tests are further divided into types, tests and routine tests.

Tests are conducted before accepting relay.

Tests are conducted on site before commissioning.

Tests are conducted during periodic maintenance.

There is generally a good deal of co-operation between electricity boards and relay manufacturers regarding relay testing. Quality control is given foremost consideration in manufacturing of relay.

Tests can be grouped into following four classes :

1. Acceptance tests.

— One new relays, first time testing.

— Tests on each product received.

2. Manufacturer's tests.

3. Commissioning test on relays and protective systems.

4. Maintenance tests.

Acceptance tests are generally performed in the laboratory. Acceptance tests fall into two categories : (i) On new relays which are to be used for the first time. On such products, intensive testing is desired to prove its characteristics and to gain information about it. (ii) On relay types which have been used earlier, only minimum necessary checks should be made. Acceptance tests are performed in presence of the customer or by the customer.

Installation tests are field tests to determine that the protection operates correctly in actual service. These are not repeated unless incorrect operation occurs. Most frequently they are performed by simulating test conditions by means of portable test sets. Other methods include :

— tests using primary current injection.

— operating tests with reduced primary voltage.

— system fault tests (faults are applied on the protected system internal/external to protected zone).

Such tests are conducted on every new installations only. The protection circuits, CTs, VTs are also checked.

Maintenance testing is done in field periodically.

Repair tests, involve recalibration and are performed after major repairs. These are generally performed in laboratory. Minor repairs done on field need not follow complete recalibration.

Manufacturers tests include development tests and type and routine tests.

37.3. TEST EQUIPMENT

(a) Primary Current Injection Test Sets

Most protective systems are fed from a current transformers on the supply cable or bus bars. PRIMARY current injection testing checks all parts of the protection system by injecting the test current through the primary circuit, of protective CTs.

The primary injection tests can be carried out by means of primary injection test sets. These sets are standard portable sets comprising :

- current supply unit
- control unit
- accessories.

The test set can give variable output current. The output current can be varied by means of built-in auto-transformers. The primary injection test set is connected to a.c. single phase supply. The output terminals can be connected to in the primary circuit of CT (37.1). The primary current can be varied by means of the injection set.

(b) Secondary Current Injection Test Sets

Secondary injection checks the operation of the protective system but does not check the primary circuit of the current transformer. However, it is rare for a fault to occur in the current transformer and the secondary test is sufficient for most routine maintenance. The primary test is essential when commissioning and new installation as it tests the whole protection system and will detect current transformers connected with incorrect polarity or relays that have been set in the wrong sequence in differential systems.

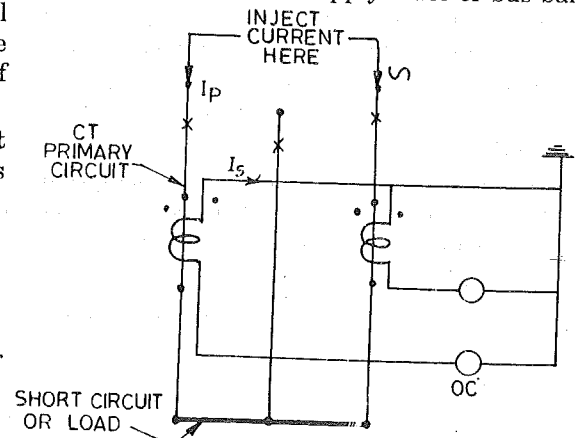

Fig. 37.1. Primary injection.

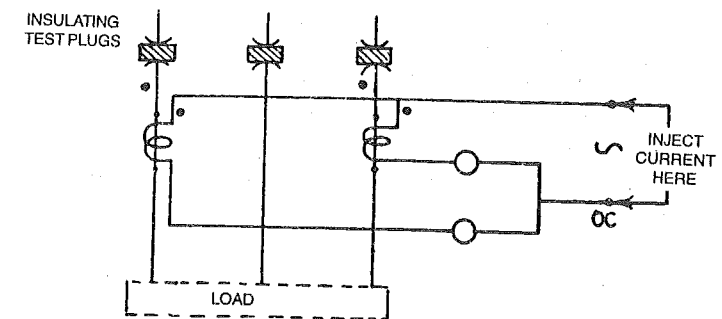

Fig. 37.2. Secondary injection tests on overcurrent relays.

Secondary current injection sets are very useful for conducting these tests.

The Standard Secondary Current Injection Testing Equipment consists of a 50 A current injection set, separate waveform filter unit and a digital counter. The equipment is designed as a portable kit for on-site testing of protective devices, circuit-breakers, trip coils motor overloads and similar apparatus. The Filter Unit should be used when testing saturating core type relays to ensure that the test current has a substantially sinusoidal waveform.

(c) Test Benches

Test benches comprise calibrated variable current and voltage supplies and timing devices. These benches can be conveniently used for testing relays and obtaining their characteristics.

D. Testing Equipment with Manufacturer

The testing equipment with manufacturer includes :

- artificial transmission lines
- heavy current test plant
- special test benches, etc.

37.4. ROUTINE MAINTENANCE TESTS

The performance of protective relay is affected by maintenance. Basic requirements of sensitivity, selectivity, reliability and stability can be satisfied only if the maintenance is excellent. In this section some basic aspects of maintenance and periodic tests are discussed.

(a) Deterioration of protective relays. The relay does not normally deteriorate by use but other adverse condition cause the deterioration. Continuous vibrations can damage the pivots or bearings.

Dampness causes weakness of insulation. The insulation strength is reduced because of absorption of moisture, polluted atmosphere affects the relay contacts, ligaments and relay parts. Dust affects insulation and rotating system. Relay room should, therefore, be made dust-proof.

Insects and vermins can cause menace. Switchgear room should be vermin-proof.

Relay maintenance generally consists of :

- Inspection and burnishing of contacts.
- Adjustments checking
- Screws checked for tightness.
- Maintenance tests.
- Foreign matter removal.
- Breakers tripped by manual contact closing.
- Covers cleaning.

(b) Maintenance Schedule

(i) Continuous Observation

Pilot supervision.

Trip circuit supervision.

Relay voltage supervision.

Battery earth fault supervision.

Bus-bar protection CT circuit supervision.

These items need continuous supervision. A trained person should be on duty to observe the above mentioned aspects.

(ii) Daily Inspection

Relay flags (every shift)

(iii) Once a Week

Carrier current protection testing.

(iv) Monthly Tests

Inter-tripping channel tests without tripping any switches.

(v) Six Monthly

Inspections.

Tripping tests.

Insulation resistance tests.

Battery biasing equipment check.

(vi) Yearly

Check tripping angle of phase comparison method.

Secondary injection tests.

Buchholz relay tests.

Test on earthing resistors.

(vii) Two Yearly

Secondary injection tests.

(c) Periodic Relay Testing

Periodic relay testing is a part of preventive maintenance. Thus, procedures and records should be planned with preventative maintenance as the guide. The tests themselves will reveal failures which would have prevented the relay from performing when called upon to operate, while properly maintained records will reveal any trends which could lead to such failures.

The interval of testing is subject to many variables, including type of relay, environment and of course history and experience. However, an annual or semi-annual schedule of maintenance is a good starting point.

Electrical Tests and Adjustments

1. Contact function. Manually close (or open) contacts and observe that they perform their required function, *i.e.* trip, reclose, block etc.

2. Pickup. Gradually apply current or voltage to see that pickup is within limits. Gradually applied current of voltage will yield data which can be compared with previous or future data and should not be clouded by such effects as transient over reach, etc.

3. Dropout or reset. Reduce the current until the relay drops out or fully resets. This test will indicate excess friction. Should the relay be sluggish in resetting or fail to rest completely, then the jewel bearing and pivot should be examined. A 4X eye loupe is adequate for examining the pivot, and the jewel bearing can be examined with the aid of needle which will reveal any cracks in the jewel. Should dirt be the problem, the jewels can be cleaned with a thin brush while the pivot can be wiped clean with a soft, lint free cloth. No lubricant should be used on either the jewel or pivot. Vacuum pump is used for sucking dust.

37.5. INSPECTION AND TESTING FOR ACCEPTANCE

Acceptance tests are done once and generally in the laboratory. These separate into the two types, first on *(i)* new products which have not been previously used, extensive testing on a sample may be desired to prove it, gain experience and knowledge, and/or additional technical information. The second type *(ii)* test on each product received from the manufacturer should be streamlined to a minimum including only important practical check points to assume that the product is up to the manufacturer's standards. After receiving the shipment, the relay should first be visually examined for damage in the transit. The relay should be unpacked carefully so as not to bend the light parts. The precautions to be taken can be enumerated.

1. *Avoid handling contact surfaces.* It tends to removal of material coating.
2. The cover should be removed before dusting it. It should not be dusted in assembled position.
3. The packing pieces are removed lightly and armature is checked for free movement manually.
4. Do not take steel screw-drivers near the permanent magnets, if any.

After the initial check, detailed acceptance tests *(i)* or *(ii)* mentioned above are carried out.

37.6. SOME TESTS ON CT'S

(a) **Testing polarity of CT by Flick Test.** A centre zero voltmeter is connected across CT secondary. A 1.5 V battery is touched to primary of CT. The deflection of pointer should be similar in case of each CT to be connected in the same protection.

(b) **Magnetisation Curve Tests.** These are conducted on CT's to prove that the turns of CT's are

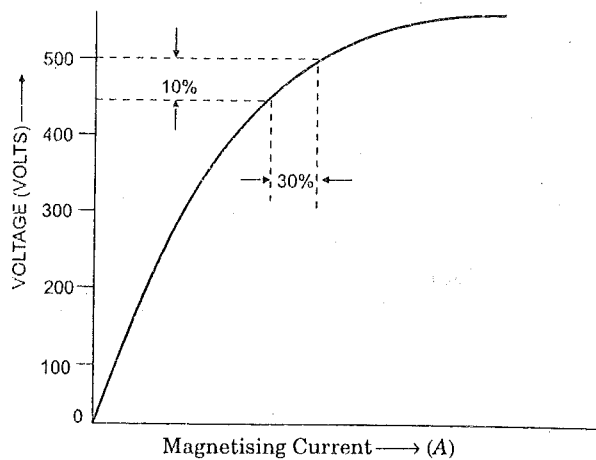

Fig. 37.4. A typical CT magnetisation curve.

not short circuited and to establish the CT characteristic and to establish the capability of CT. A typical magnetization curve is shown in Fig. 37.4. Magnetisation curves are obtained by applying sinusoidal voltage to secondary winding of CT and measuring magnetising current flowing for different values of applied voltage. Test is conducted only upto knee point which is at a point where 10% increase in applied voltage results in 30% increase in magnetising current.

(c) **Ratio Test.** The current is injected as shown in Fig. 37.6. The ratio A_1/A_2 gives the CT ratio.

37.7. SOME TESTS ON PT'S

(a) **Polarity test on PT.** As mentioned in Sec. 37.6 (a) for CT Battery should be touched to primary winding.

(b) **Ratio Check.** Primary is first made alive by energising main circuit.

Secondary voltage (measured) is compared with other existing PT connected in the same circuit.

(c) **Phase Sequence Check.** The phase sequence of three terminals is checked by means of phase sequence meter.

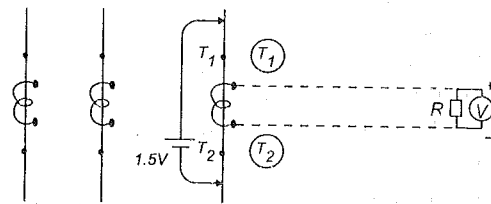

Fig. 37.3. Flick test.

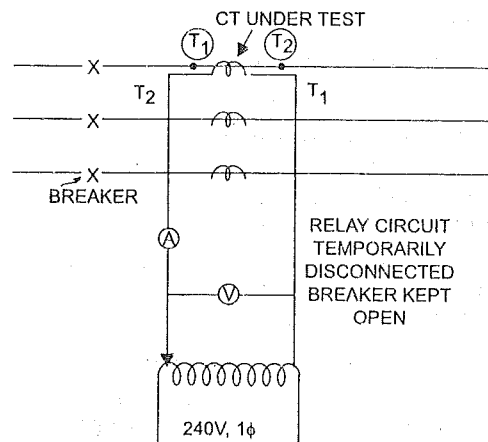

Fig. 37.5. Magnetisation curve test circuit.

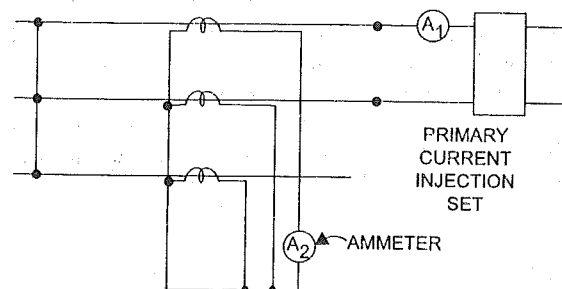

Fig. 37.6. The ratio test by means of primary current injection.

37.8. SOME TEST CIRCUITS AND PROCEDURES FOR SECONDARY INJECTION TESTS

Injection Tests. The relay coils are energized and the calibration of relay is tested.

There are several types of relays. Tests are conducted in general as follows. The lowest tap including all the turns of the coil is taken and relay operating characteristic is obtained for various time settings. The procedure is repeated for all the plug settings.

(i) Instantaneous Relays

These are actuated by current or voltage and are usually Attracted Armature Type. The currents are increased slowly till the operation occurs. The current prior to operation should be noted. This gives pick-up value. The current is then gradually reduced till the relay resets. The values of pick-up current and reset current are noted for different spring tensions.

Secondary injection current sets can be conveniently used for testing. Instantaneous relays are checked as follows. A synchronous timer with one second sweep and ten second register is incorporated in the test circuit. To begin with, the relay coil is shunted and the current is set to a low value shunt is removed. The switch is closed and the relay operation is observed. The current is gradually increased till the relay operates. The following readings are taken :

- minimum current to give operation for each current setting
- maximum current at which relay resets for each setting.

If felt desirable, response to transient overcurrent is obtained by means of CRO or U.V. Recorder.

(ii) Inverse Time or Definite Time Overcurrent or Earth Fault Relays

(iii) Inverse Definite Minimum Time Relays (IDMT) or Inverse Time Relays

A timer is necessary to test this type of relay. A typical test circuit is given in Fig. 37.7. The timer starts measuring time as soon as switch S is closed. The timer stops measuring time as soon as the relay closes its contacts and short circuit the timer circuit. The time is of the order of several seconds.

Plug setting corresponds to the minimum value of current at which the relay should start operating. However, due to friction and inertia, the relay must not start operating at values near the plug setting value. The time setting corresponds to multiplying factor to be used with operating time with time setting as unity (Ref. Sec. 26.11).

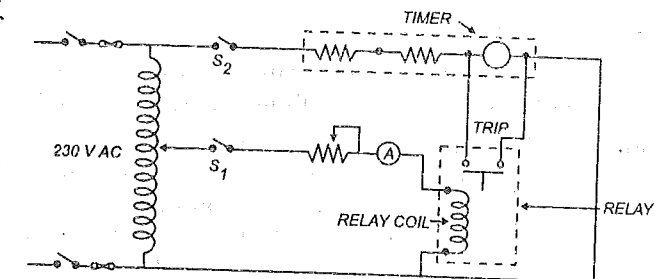

Fig. 37.7. Circuit diagram for setting an inverse overcurrent relay. (Main Switch : S)

Instantaneous relays are sensitive to transient overcurrents, but inverse overcurrent relays are not.

In this testing, the readings of operating time are taken for various values of operating currents for a time setting and plug setting. The test is repeated for various time settings and the same plug setting. Thus for a given plug setting, several characteristics are obtained corresponding to various time settings. The procedure is repeated for other plug settings. The characteristics are verified with the characteristic given by the manufacture. (Ref. Fig. 26.14).

(iv) Distance Relays

Distance relays are commonly high speed permanent magnet moving coil type in which the coils move axially or radially. In some types the relay has only one coil which is connected to rectifier bridge comparator which compares V and I so that the relay measures impedance. In other type relay has two coils on the same former. One coil is fed from rectified voltage, giving restraining

torque proportional to voltage. The other supplied from rectified current which gives operating torque. The current and voltage are separately varied to simulate the fault impedance. Readings are taken and the protective gear is calibrated. Portable test set kits are available for testing distance relays. Fig. 37.8 illustrates a test circuit.

Z_s is a high adjustable reactive impedance representing the part of the circuit upto the line containing generator, transformer etc. and Z_L , the impedance of the line having adjustable X and R . The connections of the relay which include a timer, contactor etc.

The timer is started by closing the fault switch. The timer stops by operation of the relay.

Portable test for distance relays comprise

- supply unit
- control unit
- fault impedance unit and external CT unit.

The various test can be simulated by means of these test sets, e.g.,

- phase fault injection test
- phase to neutral injection test
- testing of distance schemes
- testing of Mho/Impedance/Reactance measuring elements, etc.

(v) Directional Relays

These relays accompany over-current or distance or other types of relays. Tests are conducted on directional relays that they will not operate with only one actuating quantity.

Further, the phase angle between V and I to obtain zero torque, i.e. the point at which the relay torque changes in direction is noted. Then the phase of applied voltage is moved through 90° to get angle of maximum torque. In this position minimum operating current is required to cause relay operation at rated voltage. Fig. 37.9 gives a typical arrangement of directional relay testing.

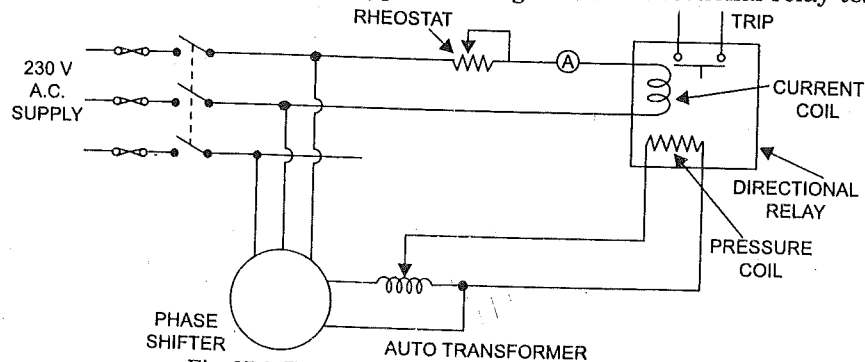

Fig. 37.9. Testing circuit at directional relay.

Description. Directional relay has two coils one energized by current the other by voltage. In the circuit of Fig. 37.9, the phase shifter can be adjusted to get desired phase angle between V and I , (Ref. Fig. 37.12 also).

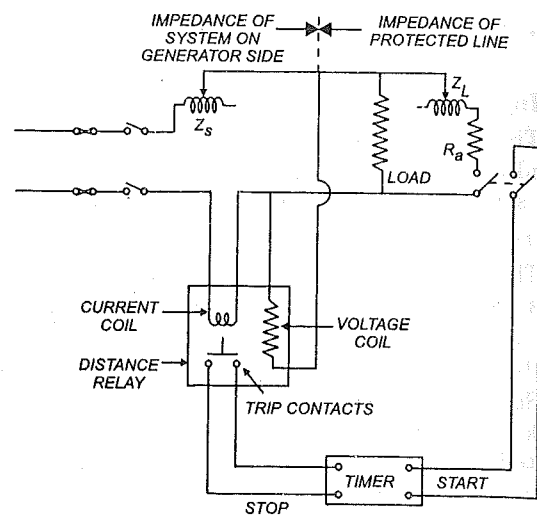

Fig. 37.8. Test circuit of distance relays.

(vi) Restricted Earth Fault Protection Testing

The polarities of CT's should be tested first. The polarity of CT in neutral connection can be tested by short circuiting one phase of star connection. The relay is replaced by an ammeter. The ammeter should read zero for correct polarity of CT's. The set up is illustrated in Fig. 37.10.

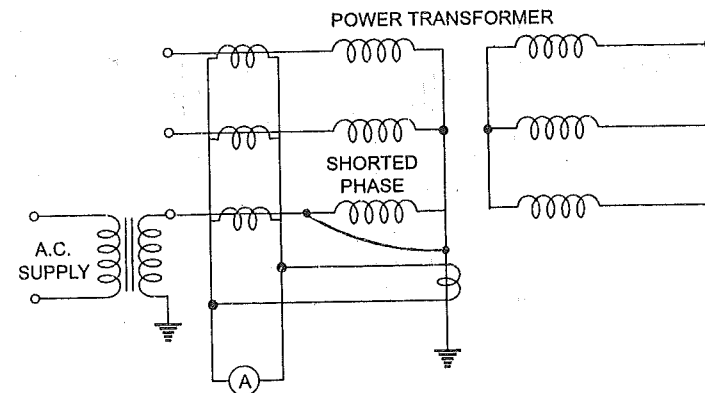

Fig. 37.10. Relay replaced by an ammeter. A.C. polarity test for restricted earth fault relay.

(vii) Testing Differential Relays

A convenient method is to pass the main current through both the halves of the restraining coil and to superimpose the differential current on one-half of the restraining coil and the differential coil. A test circuit is given in Fig. 37.11.

(viii) Buchholz Relays

A special test rig is set up to test Buchholz relays. The rig consists of two oil tanks with interconnecting pipes and valves. Compressed air is used to force the oil from one tank to other, while passing to the other tank the oil passes through the Buchholz relay.

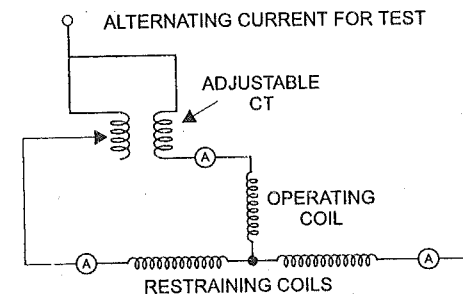

Fig. 37.11. Testing of differential Relay.

Further, to test the performance on incipient faults, air at regulated pressure is passed through the relay. Adjustments are made until desired operation of alarm and trip circuit is obtained.

(ix) Test circuit for double actuating quantity relays

When only one quantity is required to operate the relay, the test circuit are straight forward and there are very few problems. However, with two or more variable a.c. quantities, more com-

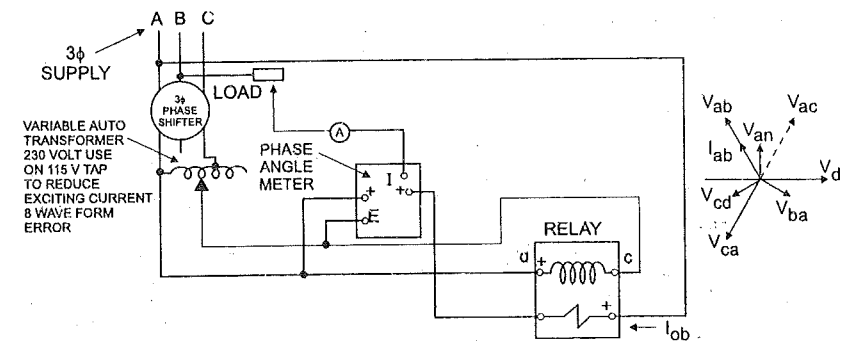

Fig. 37.12. The circuit for determining the phase angle curve of a relay operating on a current and voltage.

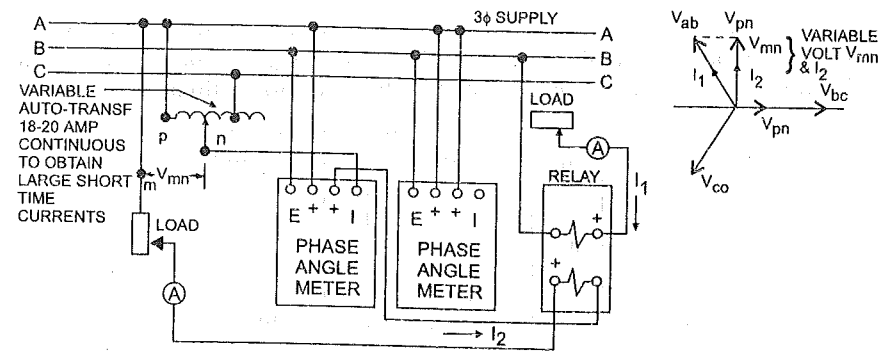

Fig. 37.13. Testing of double actuating quantity relay.*

plexity results, particularly when the phase angle between the quantities must be controlled. Typical test circuits are shown in Figs. 37.12 and 37.13.

37.9. MANUFACTURER'S TESTS*

A newly designed relay is subjected to a series of through tests by the manufacturer before it is manufactured on a large scale. Almost every possible aspect about relays is determined in these tests. Such tests are carried out on a few relays of each type. These tests are performed on a complete relay. Further, tests are conducted on protective systems including current transformers voltage transformers, and relays. The tests on relays cover :

- (i) Electrical tests.
- (ii) Mechanical tests.
- (iii) Effect of environmental conditions.

After the exhaustive type tests the manufacturer decides whether to go ahead with manufacture of the relay or some modifications are necessary in the design. The relays should conform the relevant B.S./Indian Standard/other Standards.

(i) Electrical Tests

Components of relays, sub-assemblies, relay units, complete relays, relay schemes are tested before despatching. These tests include checking number of turns in coils, to measure parameters, insulation, continuity etc. test on components. The test on complete relay include condition over their range. Slow speed relays have static tests. High speed relays have dynamic tests.

Differential relays are tested for heavy currents to make sure that the relay does not operate for through faults. Special equipment is used for heavy current testing.

Artificial transmission lines are used for testing relay schemes.

(ii) Mechanical Tests

These are conducted by the manufacturer in the factory. These cover the mechanical performance of relay such as tendency to vibrate, effect of shocks, balancing of rotor, endurance tests, deviability of springs etc. Special test equipment is necessary to perform these tests.

(iii) Environmental Tests

These include ascertaining the effect of humidity, temperature, atmospheric pressure, etc. on the relay performance. All relays are generally tropicalized.

* Ref. Sec. 43.5 for Static Relays.

37.10. COMMISSIONING TESTS

While testing the protective system at site the protection system for each zone should be tested separately to begin with and then the protective systems for the neighbouring protective systems should be co-ordinated as per the plan for the entire plant. The objectives of site testing are to ensure that

- connections are correct.
- settings are correct.
- individual protection system is functioning satisfactorily.
- the co-ordination between various protection systems is as per broad plan given by designers.

Nothing should be taken for granted and no connection should be assumed to be correct until it has been tested and proved.

During testing, it may be necessary to change the relay setting. This setting should be restored after completion of tests.

All testing at site should be done methodically, systematically as per the plan. The anxiety to commission a plant should not be allowed to affect the test schedule.

Some relay coils are not continuously rated. They should not be energized beyond specified time.

Before working on HV circuits, the adequate precautions should be taken (Ref. Ch. 14).

The procedure for testing should be well studied and understood. The testing engineer should be thoroughly familiar with protection engineering.

The instruments for site testing should be robust and portable.

Correct size of pilot wires is necessary. Smaller size causes more burden on CT's. Following aspects should be checked :

- each point is securely connected and no dust, insulation or corrosion is interfering in the continuity.
- polarity of connections is correct.
- the correct connections with terminals at remote end can be checked by loop tests.

Portable primary injection test sets are used to pass heavy current through primary of CT's of the protection system.

The generator protection may be tested by simulating short-circuit condition. A short-circuit may be placed across the bus-bars and the machine is operated with reduced field current. The operation of relay, circuit-breaker on phase faults, earth-faults, are checked and relays are set.

Primary injection tests may be utilized to prove the polarity ratio of CT's connection and protective relays.

Secondary injection tests are conducted by means of test sets.

The commissioning tests include complete check of all closing, tripping, intertripping, sequence, alarm, indication. The test may be simulated by artificially closing the circuits by means of plugs, short circuiting clips, test switch ; special kits etc.

Switching in tests should be carried out on transformers to check that the protection does not operate due to magnetizing current in rush.

Buchholz relay is tested by admitting air through the cock at the bottom of the relay and later through inlet pipe of the relay.

Electronic relays (static relays) require test-bench with special facilities.

SUMMARY

Testing and maintenance of relays and protective devices is extremely important. A failure may result merely due to lack of proper maintenance.

Testings on relays can be classified as :

1. Test by manufacturer at his work.
2. Acceptance tests.
3. Commissioning tests at site.
4. Maintenance tests.

QUESTIONS

1. Explain the importance of testing of relays.
2. Describe the secondary of current injection test of the following relays—any two.
 - (a) Instantaneous overcurrent relay.
 - (b) Inverse overcurrent relay.
 - (c) Differential relay.
 - (d) Earth fault relay.
3. State tests performed on a relay group-wise.
4. Describe briefly the following test on relay :
 - (a) Manufacturer's tests.
 - (b) Commissioning tests.
 - (c) Maintenance tests.
5. Describe procedure of CT polarity test.
6. Explain in about 20 sentences the insulation resistance measurements.
7. What are causes of relay deterioration ? Describe a maintenance schedule of a relay.
8. Describe the procedure of inspection of a relay scheme during periodic check-up.
9. Explain the procedure of commissioning tests on a protection system.
10. With the help of neat diagrams explain the laboratory test of an electromagnetic Distance Relay.
11. Describe the following terms of relays.
 - Plug setting
 - Time setting.
12. State whether true or false. Write correct statement.
 - IDMT relays are used in impedance protection.
 - Distance Relays sense vector difference between two quantities.
 - Earth fault relays are connected in the residual circuit.
 - Static Relays are used for Generator Protection.