

Appendix-A

Recent Trends and Advances Towards 21st Century

Introduction — Standards and Organisations for Quality Management (QM) — ISO 9000 Certification — BVQI Certificate of Quality Management — Feedback Loop of Site Quality and Interfaces — Interaction between Power Systems, Load, Equipment and Protection/Control/Monitoring/Diagnostics — Fault Investigations — Event Recorders — Expert Systems — SCADA — Modern Control Room Facilities for Fault Investigations — *Intelligent Circuit Breakers*.
Electrical Safety Management and Safety Aspects — Unsafe conditions and acts — Safety Procedures.
Intelligent Air Insulated Substations, (IAIS) Control and Protection Systems with Fiber Optic Cables — Fiber Optic Cables for Data Transmission, Measurement, Protection, Monitoring Systems — Fiber Optic Cables with Transmission Lines — *Digital Optical Instrument Transducer (DOIT)* — Fiber Optic CT — Communication in Power System — *Satellite Communication*.

A.1. INTRODUCTION

The electric power systems, switchgear protection and power system automation have undergone significant advancements during the last quarter of the twentieth century. *Trends* are set for new, versatile, maintenance-free, compact, reliable, safe, user-friendly, automatic equipment. The *reliability* and *availability* of power systems, plants and equipments has gained significance. The power systems, market trends, manufacturing trends are undergoing intense restructuring as a result of privatization, economic reforms, energy crisis and market pressures on cost. The significant trends have been reviewed in this concluding chapter.

A.2. STANDARDS AND ORGANISATIONS FOR QUALITY MANAGEMENT (QM)

Quality certification for plants, equipment and services has gained importance. The following organisations publish the standards related with specifications and quality of equipment, plants and services.

- International Standards Organisations (ISO) Head Quarters : Geneva, Switzerland.
- Indian Bureau of Standards (Former Indian Standards Institution), New Delhi.
- Bureau Veritas Quality International (BVQI).

The list of ISO and IS Standards on Quality is given below. These standards are followed by Manufacturers, Consultants and Customers (users) of electrical plants and equipment.

ISO	IS	Title
ISO : 9000	IS : 14000	Quality Management and Quality Assurance Standard. Selection and Use : 20 Systems Elements
ISO : 9001	IS : 14001	Level 1 : Design/Development Production, Testing in Factory Installation and Servicing
ISO : 9002	IS : 14002	Level 2 : Production and Installation all elements, some less stringent.
ISO : 9003	IS : 14003	Level 3 : Final Inspection and Tests - half the elements, low stringent.
ISO : 9004	IS : 14004	Guidelines : Maximising benefits and minimising costs.

A.3. ISO 9000 CERTIFICATION

ISO 9000 Certification is given to a manufacturer or an organisation as a recognition of the Quality. The duration of the certificate is 3 years.

* Also refer : Ch. 52, Table 52.2 ; Ch. 43-C, Ch. 46-A Ch. 47, Ch. 48, Ch. 50, Ch. 52 and Ch. 53 for recent advances.

The certification is renewed after specified period (3 years) and re-audit.

The European Economic Community and other buyers in the world have insisted on ISO Certification. Products to be exported from India should have high quality. The manufacturer and the products must have an ISO 9000 Certification to be acceptable in the export market. For increasing exports, ISO Certification is essential. Other benefits are improved performance, reduced wastage of manpower/materials/paper work and time due to systematized Quality Approach. This helps in withstanding Global and local competition.

Under the recent economic reforms India has ambitious plans for increasing export. The ISO 9000 certification is a target of various manufacturers aiming at increasing their exports and business.

BVQI Certificate of Quality

BVQI stands for "Bureau Veritas Quality International". It is an International Organisation dealing with Quality Assessment and Certification.

BVQI assesses the Quality of Design, Manufacture, Supply and Services etc. and gives a Certificate of Quality to the Manufacturer.

BVQI certificate has reference to the following standards on Quality:

- EN 29001-1987
- ISO 9001-1987
- BS 5750-Part I, 1987.

Example of a BVQI Certificate is given below.

BVQI
Certificate of Approval

Bureau Veritas Quality International Certify that the Quality Management System of the Supplier :

M/s has been assessed and found to be in accordance with the requirements of the Quality Standards for Design, Manufacture and Supply of Equipment and Plants as detailed below.

Scope of Supply : (as an example)

- Power Station Equipments
- Substation Equipments, Industrial Electrical Equipment
- Switchgear and Controlgear
- Transformers, Motors, Generators, Electronic Controllers.

Quality Standards

- EN 29001-1987
- ISO 9001-1987
- BS 5750-Part 1, 1987

This certificate is valid for a period of three years from 1-7- 1994 to 30-6-1997.

SEAL
and
SIGNATURE OF AUTHORITY

A.4. TOTAL QUALITY MANAGEMENT (TQM)

TQM is a total professional quality system covering product, plant, project and services. The total quality management system takes into account the customer's requirements. The quality checks are applied at every stage - from raw material to finished product, despatch, installation, commissioning, operation and maintenance.

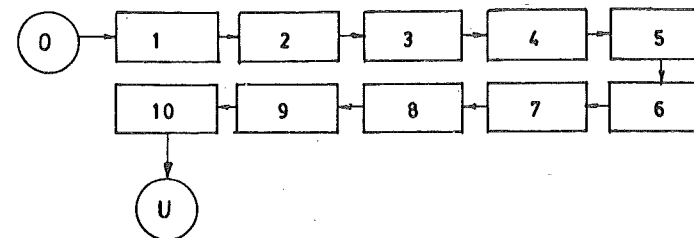

- (0) Order (1) Specifications (2) Design (3) Production, Testing (4) Despatch, Transport
- (5) Receiving, Unloading, Storage (6) Civil Works (7) Installation (8) Testing Commission
- (9) Operation (10) Maintenance, Troubleshooting, (U) Performance

Fig. A-1. Stages of TQM.

Note : 5 to U are covered by Field Quality Management.

A.5. FIELD QUALITY (SITE QUALITY)

More than 50% damages occur after despatch of equipment from the manufacturer's works. Field Quality (Site Quality) deals with quality aspects of equipments and plant at site. Field Quality covers Civil Works, Receiving, Storage, Installation, Testing, Commissioning, Operation, Maintenance, Overhaul, Retrofitting etc.

At every state, certain organisations are responsible for certain functional activities.

The following organisations and personnel are responsible for Quality in respective activities and interface with others.

- User (Customer)
- Supplier
- Consultant
- Designer
- Erection and Commissioning Contractor

Respective responsibilities are usually defined and agreed mutually before signing the contract agreement. The Quality systems are followed at each stage of the project.

Quality Chief is usually appointed for overall responsibility and implementation.

Areas Concerning Site Quality Management (Fig. A.1 : 5 to U)

Field Quality in

- 1. Civil Works
- 2. Erection, Commissioning Projects
- 3. After Sales Services
- 4. Trouble Shooting Assistance
- 5. Failure Analysis
- 6. Training to Customers Operating Staff

A.5.1. Feed-back Loop of Site Problems and Interfaces

System of site problem feedback analysis and corrective actions is established to eliminate the repetitive site problems in equipment and plants. Performance is influenced by Power System, Load, Plant/Equipment and environmental influences.

A.6. INTERACTIONS BETWEEN EQUIPMENT, POWER SYSTEM, LOAD

Electrical power system, load, impose stresses on various equipment/machines. During abnormal operating conditions in the power system, the electrical equipment gets overstressed. Likewise during abnormal operating condition in the equipment/machine the disturbances and excessive stresses are transmitted to the power system. The protective systems and control systems constantly watch the interaction between the equipment/machine and the power system.

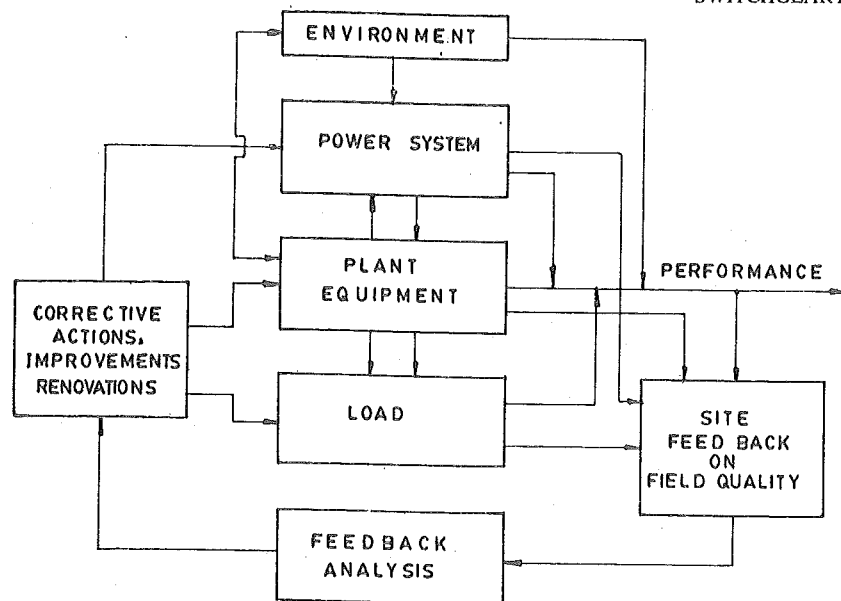

Fig. A-2. Field quality feedback loops with corrective/improvement actions.

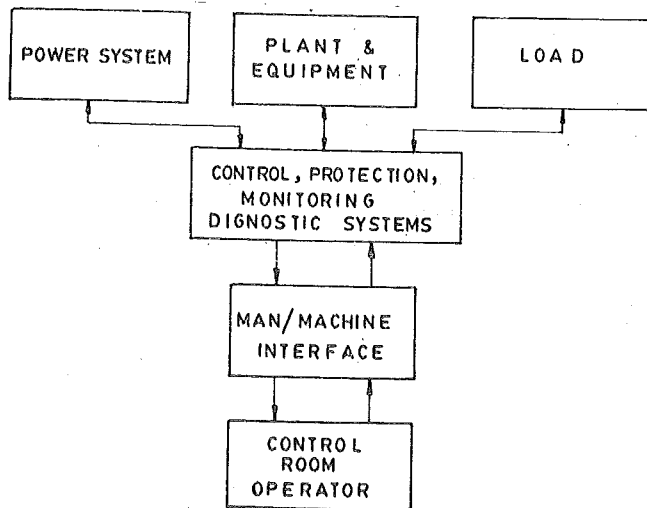

Fig. A-3. Man-Machine Interface and Interactions.

A.7. FAULT INVESTIGATION

Faults occur when stress is more than withstand limit. Faults occur at weakest point in the plant, equipment.

After occurrence of a fault, several actions are initiated by the plant manager. These include :

1. Repairing/Replacing the faulty equipment/plant.
2. Recommissioning and restarting the supply.
3. Fault investigation.

Fault investigation is carried out by an expert-team. The objectives of fault investigation is to determine the cause of fault and to take actions to eliminate repeated faults of similar nature in future.

The steps in fault investigation are as under :

(a) *Observation and Data Collection* : The faulty part is closely observed. The details about load condition, supply condition, frequency, events prior to the fault, operation of relays operation of circuit breakers, readings of event recorders, records on fault recorders, etc are helpful. System conditions are also noted.

(b) Discussions with operation and maintenance staff regarding occurrence of fault, previous history, other information.

(c) Listing of possible causes, percent probability, method of checking etc. are listed in the form of a table.

(d) Analysis of the various possibilities and investigation to confirm/eliminate them.

(e) After eliminating some possibilities from the list the remaining possibilities are investigated further.

(f) Conclusions are drawn about one or more possible/confirmed causes of fault.

(g) *Final Reports of Investigation* : Submit report on investigation of the fault. The report includes the causes of failure and corrective actions to be taken for preventing similar faults and other faults in future.

Table A-1. Check List for Fault Investigation

S. No.	Description	Observations	Remarks
1.	Visual inspection of failed equipment	Insulation, terminals, conductors, earthing, connection, parts	— Very close examination gives certain clues.
2.	Review of sequential events prior to fault. Log book and event recorder records, operating duty.	From log book, personal interviews, event recorder	— Root cause of failure can be traced by review of sequential happenings
3.	Record of relay operation, timings, breaker operations, fault recorder report	From relay panel, event recorder, fault recorder	— Fault recorders give oscillograms of pre-fault voltages, currents, other parameters.
4.	Study of layout and operating duty and observations regarding critical aspects	To trace current path upto fault and neutral return path.	— Root cause is often due to weakness in system design/operation.
5.	Investigation of failed equipment components, insulation, current carrying cooling systems, mechanical operation	Person should be experienced regarding functional requirements of each part	— Whether failure occurred due to mechanical stress, environmental stress, voltage stress, current stress, thermal stress, combine stress
6.	List of possible causes and percentage possibility	Brain storming without bias is useful	— Suggestions should be noted
7.	Logical deduction regarding elimination of possibilities	Scientific approach is helpful,	
8.	Conclusion about cause/causes of fault		— Come automatically by process of elimination
9.	Recommendations regarding corrective actions for elimination of root-causes	— Immediate — Long term,	

Refer "Expert Systems" — Sec. 50.11.

*Refer the book : "Electrical Safety Engineering and Management" by S. Rao and H.L. Saluja, Khanna Publishers, 1998.

Notes For Example : Neutral not earthed, Surge arrester not provided, Surge suppressor not provided, : 1. repeated duty without regular maintenance, Clearances less than adequate, Ventilation inadequate, Exposure to environmental stresses, humidity too high.

2. *For Example* : (a) Insulator rod failed mechanically/under voltage stress by tracking or flashover. (b) Vacuum interrupter failed due to loss of vacuum (c) Contacts failed due to loss of spring tension (d) Terminal failed due to loose hardware.

A.8. ELECTRICAL SAFETY

Electricity is useful but dangerous. With more and more use of electricity there is a tendency to be careless and negligent. Safety must be an important policy of the organisation. **The objective should be hundred percent safety and zero percent accidents.**

During earlier years, the electric accidents were attributed to human lapse. It was believed that 80% accident occur due to human lapses. This theory is not accepted any more. The modern theory is : *the accidents are caused by more of management failure and less by human error.* Ensuring safety is the prime responsibility of the management. The following steps are recommended to ensure electrical safety and to prevent electrical accidents.

(a) To declare the safety policy of the organisation and its objectives, Top management must issue writtendown safety policy.

(b) To organise safety department and safety organisation. To assign responsibilites to safety personnel.

(c) To conduct safety Audit of the plant and equipments. **Identify unsafe conditions and acts. To recommend corrective actions.**

(d) To establish safety procedures, procedures for issuing work permit, procedure for safety key system etc.

(e) To bring awareness about dangers of electricity and preventive actions.

(f) To arrange training courses for executives, supervisors, technicians, labour, contractors regarding safety procedures and acts.

(g) To establish safety documentation system.

(h) To replace unsafe equipment by new safer equipment.

(j) To carryout improvements in the plant as per recommendation of safety Audit.

A.8.1. Electrical Safety Management

Electrical **unsafe conditions** include :

1. Bare live conductors accessible by workers or operators.
2. Ungrounded structures, bodies, tanks.
3. Unshielded outdoor installation without overhead shielding wires for lightning protection.
4. Loose electrical connections in power circuit resulting in overheating, melting, fires.
5. Overload conditions without overload protection.
6. Oil insulated Electric Equipment/Machines which are explosive or fire-prone. Special fire fighting facility is necessary.
7. Rotating machines/reciprocating machines etc. without safety guards, safety covers.
8. Electric short-circuits not cleared by main protection and backup protection.
9. Failure of main equipment, failure of protection systems, failure of interlocks, sequence systems.
10. Flashovers done to overvoltages, dirty insulation, inadequate clearness, sharp corners, switching surges, lightning surges.
11. Electric leakage currents etc. The hazards due to electric.

Following **safety actions** are essential in Electric Plant Management:

- Follow safety rules and regulations recommended by Indian Electricity Rules.
- Written down safety policy document
- Organisation of safety with safety Manager, safety supervisors.
- Documents for safety during project construction covering civil works, storage/handling, Erection, Testing, Commissioning.
- Documentation for safety during Operation and Maintenance.

- Approval of Electrical Safety Inspectors for electrical installation before commissioning.
- Work Permit System
- Entry pass system for plant and auxiliary rooms.
- Training to personnel for safety.
- Design and construction certified by Electrical Safety Inspectors.
- Earthed fences with doors and locking system for switchyards.
- Procedures for Analysis of Accidents.
- Good housekeeping and disposal of rubbish.
- First Aid Facilities.
- Fire Prevention and Fire Fighting Facilities.
- Procedures of Safety Audit.

A.9. EVENT RECORDERS, FAULT RECORDERS AND EXPERT SYSTEMS, SCADA IN MODERN CONTROL ROOMS

The control room operator can look into the records of event recorder and know sequential events. Fault recorder gives oscillograms of various variables prior to the fault and during the fault. Expert system gives clue regarding possible causes based on analysis of data.

Event Recorder

It is an on-line recording instrument with paper print out. Every event in the plant related with the main equipment, auxiliary equipment, protective relays, auxiliary supply etc. are recorded.

Example of a Record on Event Recorder :

Date	Time	Event
24-3-1994	15:30	Circuit breaker CB25 off
24-3-1994	16:03	Earth-fault relay EF20 for cooling fan motor protection tripped
	16:03	Cooling fan motor OFF
24-3-1994	17:00	EF relay reset
	17:02	Cooling fan motor ON

Fault Recorder

It is a Recording instrument with provision of multi-channel print-out facility. The number of channels may be 10, 20, 30.

For each essential parameter, one channel is provided. *e.g.* Bus Voltages, Line Currents, Clock, Time, Temperature of transformer, kVA load, Frequency, etc.

In the event of a relay operation, the Fault recorder is initiated into action. The records from *memory* of earlier 60 milliseconds and subsequent several seconds are given in the Print out. These records are useful in analysing the Fault or disturbance and pin-pointing the cause, taking remedial actions.

Expert Systems

Artificial Intelligence (AI) and Expert Systems are being used for assisting the Control Room Engineer, testing Engineer, Maintenance Engineer etc. The Software packages are now commercially available or being developed for required application.

An expert system incorporates programs base on AI-Language NS "IF THEN" Rules. The Expert system provides a list of possible problems and solutions with % possibility.

The list is useful to Engineers for finding solution and taking corrective action without waste of time.

Expert Systems for Maintenance and Trouble Shooting

Plant Inspection System : The expert system for Maintenance Engineer for inspection of Plant and equipment. PSI helps periodic Inspection and provides guidelines for Predictive Failures and Preventive maintenance.

One Line Monitoring Expert Systems

Such systems receive on line data periodically. The expert system analyses the data and predicts the possibility of failure in advance, preventive measures to be taken by the maintenance staff to avoid serious trouble. *e.g.* for a transformer overheating, the Expert System gave a following Display on the Personal Computer Screen :

305 MVA 400 kV Transformer NO TRP003,

Oil Temperature : 80°C,

Rising at a rate of 3 C in 15 min.,

Possible Causes :

— Cooling Oil Circulation Choked	70%
— Overload	20%
— High Ambient Temp.	5%
— Cooling Fans Outage	5%

Check Cooling Oil Flow,

SCADA

Supervisory Control and Data Acquisition systems provided in modern Control Rooms of power plants/Sub-stations/Control Centres perform several on line functions with the help of data collection system/Data transmission system/CRT display/Man-machine/Interface and Microprocessors.

With the help of the modern facilities, the troubles can be quickly diagnosed and corrective actions can be taken quickly and precisely without trial-and-error/guess work.

A.10. INTELLIGENT AIR INSULATED SUBSTATIONS (IAIS)

Conventional air insulated substations are widely use in India and other developing countries. Gas Insulated Substations (GIS) are widely use in various developed countries. Recently the concept of Intelligent Air Insulated Substations (IAIS) has been introduced.

Compared to the Conventional Air Insulated Substations, the IAIS have several advantages as under :

- *Compactness* : IAIA are 30 to 40% smaller in total floor area due to integrated multiple function equipment (*e.g.* one breaker and two insulators mounted on a common base structure, earthing switch mounted on the support frame of the C.T.).
- Lesser number of equipment, lesser number of isolators, lesser number of foundations.
- Number of high voltage connections reduced by 50%
- Adequate safety clearances.
- Reduced maintenance.
- Integrated Numerical Protection, Control and Monitoring systems. Self monitoring of over-all system.
- Improved layout with higher safety margins.
- Fibre-optic Cables in place of insulated copper cables for control, protection and monitoring. With this development conventional current transformers upto 1 ampere secondary circuit and 5 ampere secondary circuit are no more needed.

Short-circuits due to copper conductors in secondary circuit of CTS are eliminated. Safety is improved.

- High-speed process bus data signal transmission. The IAIS concept utilises digital data processing and data transmission through Fibre-optic cables.

The data is digitized before it leaves the primary equipment (*e.g.* a CT, a CB).

The measurement, control and protection signals in the substation are all transmitted over the process bus. The output stage of the main equipment (*e.g.* a CT, a CB) is in each case a solid state switch with continuous safety monitoring.

- Use of Digital Optical Instrument Transformer (DOIT). Current and voltages are measured by the DOIT systems.

Conventional CTs and VTs are used for primary to secondary conversion of current and voltage, but the electrical data signals are converted into optical signals and transmitted over fiber-optic cables.

This allows smaller instruments to be used and simplifies the HV insulation of secondary cables.

Capacitor Voltage Divider is used for voltage reduction. The voltage values are sampled and then digitalized for transmission over the fibre optic link.

- Improved Monitoring of Power Transformer.

The Power Transformer in IAIS are equipped with electronic control unit which records every details of operating behaviour.

This helps in predicting over loading condition and its influence on life-time of transformer. Standard monitoring data is received from various sensors (Temperature sensor, Buchholz relay, Pressure Switch, etc.)

In addition tap changer performance, automatic self partial discharge measurement, oil quality checks are monitored automatically.

Table A-2. Comparison between Three Types of EHV AC Substations

	Conventional Air Insulated	Intelligent Air Insulated (IAIS)	SF ₆ Gas Insulated (GIS)
Initial cost	Lowest	Moderate	Highest
Floor area	100%	60%	15%
Maintenance	Highest	Moderate	Lowest
Reliability	Lowest	Moderate	Highest

For further details : "*Electrical Substation Engineering & Practice*" — S. Rao, Khanna Publishers

A.10.1. Reduction in Floor Area with IAIS

Compared to the conventional air insulated substations, the IAIS substations require only 60% floor area. The following features are adopted in IAIS for the space reduction.

(a) Compact Switching Module. One circuit breaker pole, two pantograph isolators with earthing switches are mounted on a single support structure and foundation (Fig. A.4).

(b) Triple pole gas insulated isolators

Serving as isolators and bus support insulators (Fig. A.5).

(c) Earthing Switch Mounted with the Voltage Transformer pole (Fig. A.6).

(d) DOIT-Current Transformer (Digital Optical Instrument Transformer) mounted directly on a circuit-breaker interrupter-end (Fig. A.7).

(e) Truck mounted draw-out type out-door circuit-breakers (Fig. A.8).

The concept used in medium voltage draw out type switchgear is extended to outdoor triple pole circuit-breakers. The triple pole circuit breakers is provided with jaw-type terminals.

The circuit-breaker is drawn out on the rails to obtain isolation. The need of a separate isolation is eliminated.

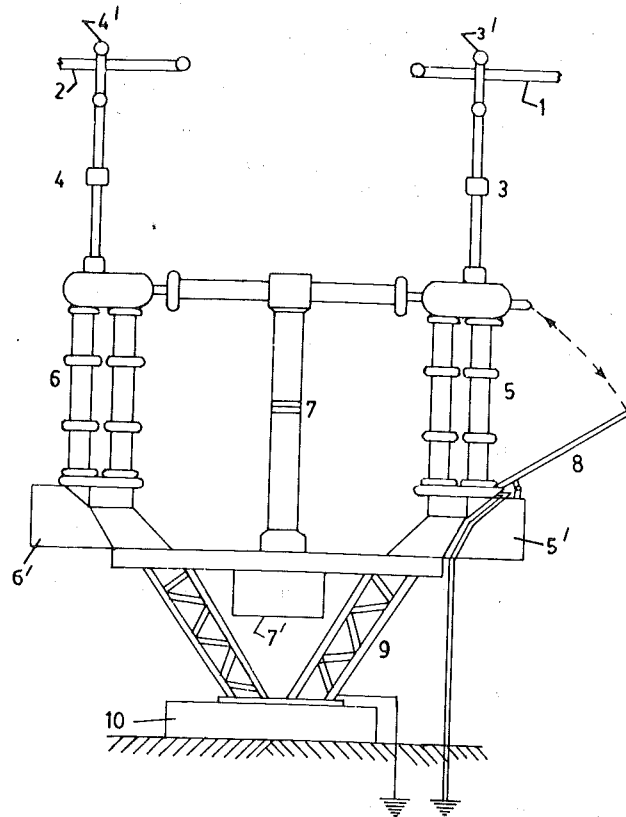

- (1, 2) Overhead busbars
- (3, 4) Pantograph Isolators (Sideview)
- (5, 6) Insulators of 3, 4
- (5', 6') Mechanisms of 3, 4
- (7) Mechanism of 7
- (7) SF₆ Circuit-Breakers
- (8) Isolator
- (9) Structure
- (10) Foundation

Fig. A-4. Compact switching module with one circuit breaker, two isolators, one earthing switch.

- (1) Insulator enclosure
- (2) Fixed contact
- (3) Moving contact
- (4) Insulating rod
- (5) Operating cylinder
- (6) Mechanism
- (7) Busbars
- (8) Sliding contact for 3

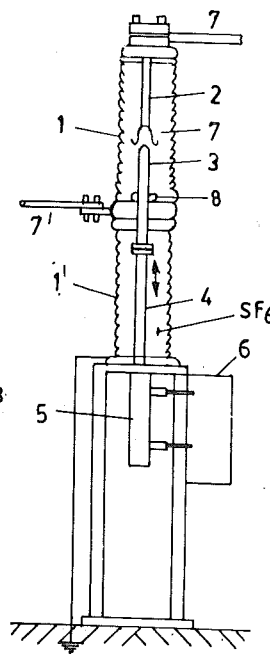
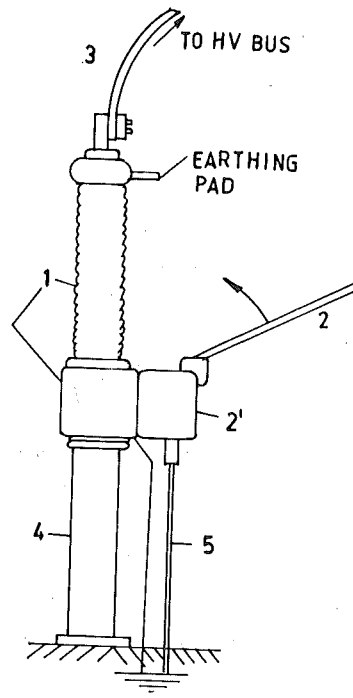
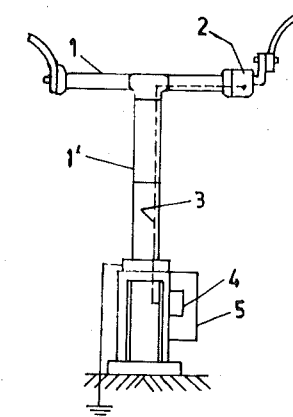

Fig. A.5. Gas insulated isolator-cum-support insulator (one pole of triple pole isolator)



- (1) VT. (2') Operating mechanism of
- (2) Earthing switch.
- (3) Flexible lead from 1.
- (4) Support structure

Fig. A.6. Earthing switch mounted on the frame of a voltage transformer



- (1) Double interrupter of 420 kV SF₆ CB
- (1') Hollow porcelain of 1
- (2) DOIT CT
- (3) Fibre optic cable between 2 and 3
- (4) Fibre optic junction box located in 5
- (5) Mechanism housing and control cabinet of CB

Fig. A.7. DOIT current transformer (2) mounted on circuit-breaker interrupter end.

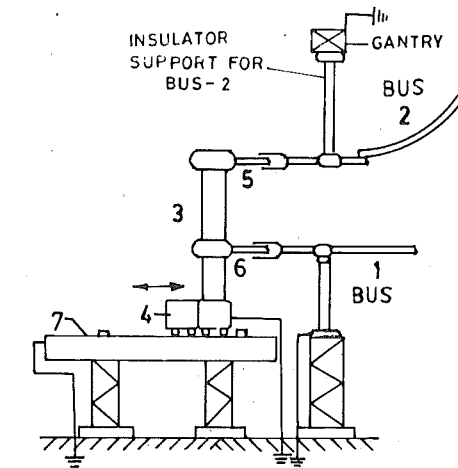

- 1, 2. Busbars
- 3. Truck mounted circuit breaker
- 4. Truck with withdraw mechanism
- 5. Isolating jaw between 2 and 3
- 6. Isolating jaw between 1 and 3
- 7. Supporting rails for movement of 3

Fig. A.8. Truck mounted circuit breaker with isolating terminals.

As a result of above mentioned improvements, the number of foundations in the switchyard is reduced.

The required floor area is also reduced. Figs. A.9.A and A.9.B give the comparison.

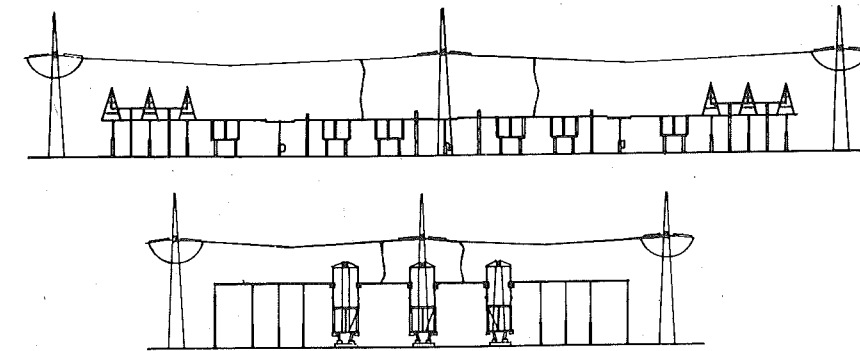

Comparison of a conventional 420-kV switchyard with a 1 1/2-breaker bus arrangement (a) and the same substation based on the IAIS concept (b). The number of components is considerably reduced in the latter case.

Fig. A.9.A. Conventional and IAIS substations.

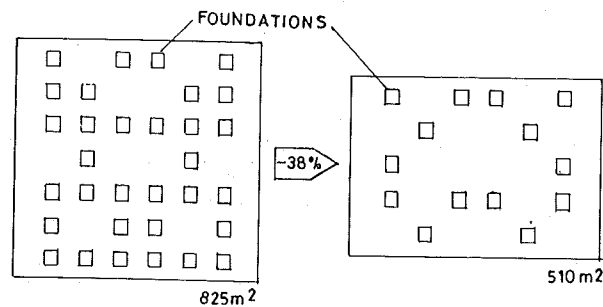

The IAIS concept reduces the site area and number of foundations needed for a substation, here for a 145-KV switchyard with three switchbays.

Fig. A.9.B. Comparison of floor area requirements of (a) Conventional (b) IAIS.

A.10.2. Control and Protection System in IAIS with Fibre-optic Cabling

The modern concepts of combined control, protection and monitoring are used in the Intelligent Air Insulated Substations. The salient features are as follows :

- Distributed signal processing
- Numerical technology
- Deterministic, fiber-optic process bus (100MHz, as per IEEE 802.12)
- Modular hardware and software
- Software library containing the control and protection related functions.

The high level of functional and operational reliability is in large part due to the use of numerical technology. High reliability is also ensured by early detection of faults evolving in the primary equipment. In addition, erroneous switching e.g. without definite cause or due to faults outside the monitored zone is avoided. Further benefits of the numerical technology include :

- Settings based on primary units
- Storage of events and analogue signals, with time data, for later analysis.
- Self-monitoring functions in support of the Maintenance on Demand principle.
- Simplified spare parts inventories due to smaller number of modules.

A.10.3. High-speed Optical Process Bus for Data Signal Transmission

Communication, which is digital, is over a fiber-optic, deterministic process bus in redundant mode (Fig. A.10). The signals are digitized before they leave the primary equipment. Measurement, protection and substation control signals are all transmitted over the process bus. The output stage of the main apparatus is in each case a solid-state switch with continuous self-monitoring facility.

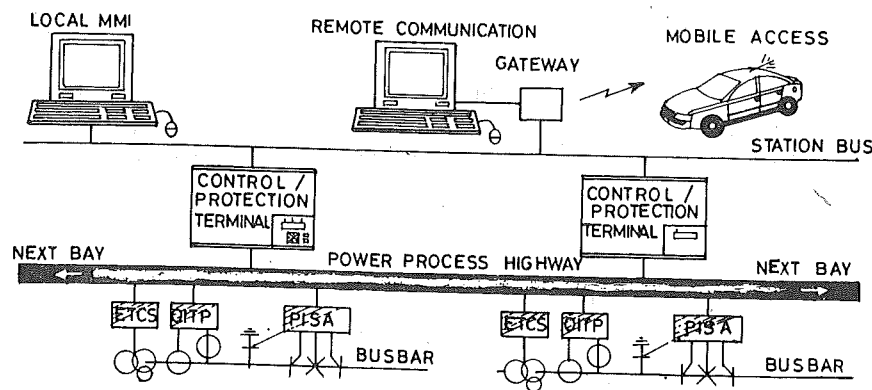

The process bus carries all of the information transmitted between the HV substation and the control system. Redundant systems with two buses are also possible.

Fig. A.10. Data transmission and interface in IAIS.

During commissioning, the overall system is tested with the help of special software which checks the data sent to and from the bus. This allows all of the functions to be verified, settings checked and all tolerances tested.

Monitoring of the total system takes place continuously during operation. Any disturbances that occur are displayed and recorded. The principle of Maintenance on Demand has been adopted, i.e. maintenance is carried out in the event of an alarm, abnormal switchgear behaviour, or when the equipment signals that maintenance is needed.

A.11. FIBER OPTIC CABLES FOR DATA TRANSMISSION, MEASUREMENT, PROTECTION, CONTROL MONITORING SYSTEMS

In conventional hard wired copper systems, the primary current and primary voltage is stepped down in conventional CTs and VTs respectively. Secondaries of CTs and VTs must be insulated from the primary high voltage with adequate insulation. The secondary circuit must also be insulated from earth. The measurement, protection, control and monitoring circuits are by insulated copper wires. The electromagnetic interference (EMI) produce disturbances in data transmission, and errors in the measurement. The copper cables have several limitations and disadvantages as regards data transmission. The fibre-optic cables do not have these limitations and disadvantages.

The Optical-Fiber Cable technology has been developed on the basis of theoretical work by Dr. Charles Kao, (ITI, USA) during 1966. The first commercial fiber optic cable system was introduced in 1977. The fiber optic technology in materials, structures and applications has progressed rapidly after 1985 and substantially better materials and structures with less loss and low cost are under development.

Table A-3. Application of Fiber Optic Cables in Electrical Power Systems

Application Category	Remarks
1. Long distance data communication	— Network supervision, control, data acquisition (SCADA) — Communication between power stations, substations, load control centres — Fibre optic cables laid along with transmission line conductors
2. Short distance data communication	— Plant process control and monitoring — Substation control and monitoring — HVDC convertor valve thyristor control — SVS control
3. Measurement, protection, control, monitoring of LV, MV, HV, EHV, HVDC systems	— Use of optical current transformers on secondary side between power conductors and protection and control system
4. Industrial plant control	— Digital, microprocessor based, no EMI. A few cables for large number of communication messages at time, no need for electromagnetic screening, fiber optic cables do not need phase to ground insulation.
5. Substation control	
6. Power station control	
7. Communication between control rooms and plants	

A.11.1. Fiber-Optic Technique

In fiber-optic medium the data is transmitted in optical (light) form through a special optical fiber. Both fiber and fiber words are used in literature) Figs. A.11, A.12 shows the basic structure of an fibre optic cable. The optical fiber is a dielectric, long, flexible cylinder of small diameter (125 μm) which guides the light along the direction of its longitudinal axis almost without loss, even when it is bent. The light entering the fiber within a certain solid angle around the optical axis of the fibre gets totally reflected and does not leave the fiber. The data is transmitted from one end of the optical fiber to the other end in the form of light.

Fig. A.12 illustrates a cross section of complete fiber optic cable system.

Electrical signals (E) are converted into optical signals in E/O converters.

The electrical signals need level adjustment, adjustment of impedance before E/O conversion. This is done in the electrical interface circuit.

Semiconductor light sources (L.E.D., L.D.) are used in E/O converters. (L.E.D.= Light Emitting Diodes, L.D. =)

Through intensity modulations corresponding to the electrical signal, the E/O converter (transmitter) produces optical signals of desired wave-length.

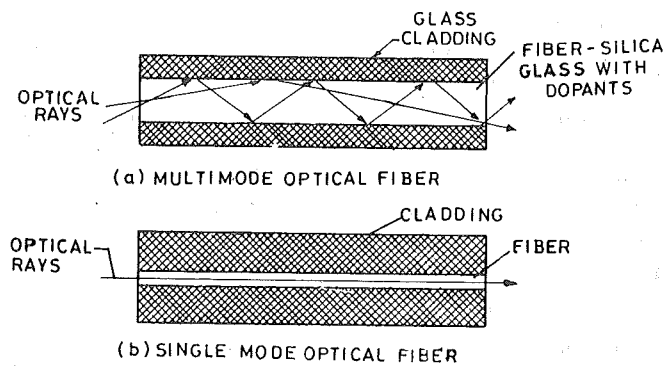
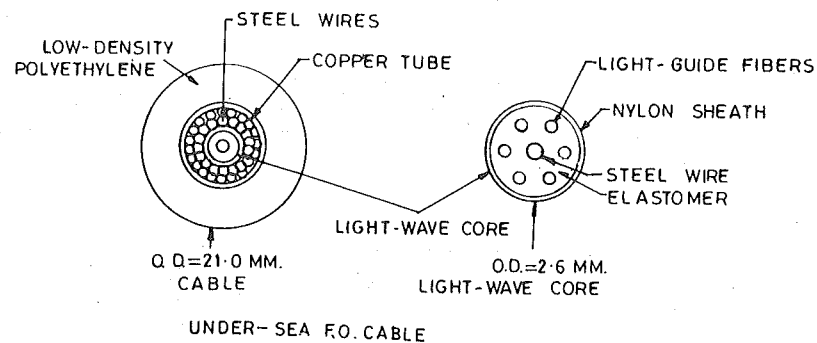

Fig. A.11. Fiber optic principle. (a) Multi mode fiber (b) Single mode fiber.



Undersea cable with copper tube. Copper tube carries current for repeaters. Fig. A.12. Fibre optic cable (cross-section).

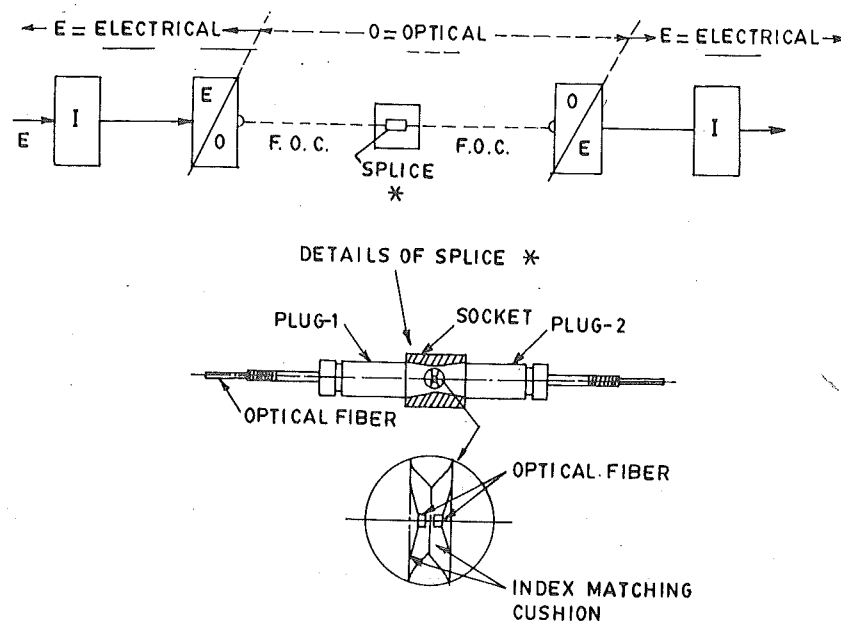

Fig. A.13. Long distance fiber optic cable system between two electrical interfaces I_1 and I_2 .

The optical signal is guided from transmitter via an optical fiber cable to the optical receiver (O/E) converter.

The optical receiver (O/E converter) receives the optical signal and transforms, back into electrical signals.

After adjustment of level and impedance, the original signal is available. 850 nm, silicon photodiodes are used. At 1300 nm germanium photodiodes are used.

In practice the interface circuits and E/O and O/E converters are offered as a signal transmission terminal.

A.11.2. Fiber Optic Data Transmission

This technique is being used for machine-tool control or plant process control and power system protection and control.

The conventional electronic signals are communicated through shielded copper wires of good conductivity. The electrical noise, electromagnetic interference, tend to disturb the signals. The conductor need adequate phase to ground insulation which becomes very complex and costly for EHV systems. One method of overcoming this problem is to employ fiber-optic cable for transmitting the control signals. Fiber-optic cable consists of a specially developed Silica glass cable. The light signals can be transmitted through such cable very efficiently and the effect of electrical noise on transmission is completely eliminated. The light signals are generally digitized.

The transmitter at sending end converts the electrical pulses into light pulses. These light pulses are transmitted through the FO cable. At the receiving end the light signals are converted into electrical signals.

At present silica glass optical cables have been developed for working lengths of 150 km before repeaters are necessary. They can handle data rates in excess of 100m bit/sec.

Development of optical sensors and integrated optics has made a major impact on protection signalling in early 1980's.

Commercial optical link current transformer have been developed the scheme incorporates DOIT-CT mounted on hollow insulator. The output of DOIT CT's is given to interface unit on ground level via fiber-optic cable. Optoelectric techniques are also used for controlling HVDC thyristor valves.

(Ref. Fig. A.12). The transmitter drives a gallium arsenide light emitting diode (LED). Light pulses from the diodes are transmitted through fiber-optical cable to relay room. In this room the light signals received from FO cable are converted into electrical pulses by receivers. The electrical signals are supplier to static relays. Thus the optical system forms a link between outdoor CT, VT and indoor static relays, Protection control and monitoring system.

Digital Message System. Signals and physical representation of message, and therefore carries the information to be processed. The Binary signals can assume only two values either '0' or '1', the '0' value represents not present and '1' value represents present. The logic operations AND, NAND, NOR, OR and the combinations thereof manipulate logic functions in form of binary language of '0', '1'. A change of signal state of a binary device represents in its message content elementary decision between two possible values 0, 1. In technical terminology, it contain the unit 'bit' called binary digit.

When a varying analogue quantity is to be converted into digital message, it should be converted into digital form in A/D conversion device.

A code is the assignment between individual values of the quantity and the signal states of several binary positions by means of which these values are to be digitally represented.

The analogue circuit quantities or messages are converted into digital messages. These digital messages are in form of 0-1 pulses having certain code. The frequency of signals may be voice frequency or high radio frequency. The central optical fiber core (light guide) is usually about 125 micro-meter thick and made of pure silica glass with dopants added to control refraction index.

The doped silica glass core has glass cladding of about 1% lesser refraction index than that of the silica core. As a result the cladding serves to confine the light rays within the fiber.

Multimode fibre will propagate light rays in several modes as shown in Fig. A.11A) The core of multimode fiber should be more than 50 micron, and light wave lengths used for multimode are 0.8 to 1.55 micron.

Thinner core (0.85 micron) can restrict the propagation to single mode (Fig. A..) Single mode fiber has lesser transmission loss.

Fiber optic cable is weaker in tensile strength. Fiber optic cable should not be subjected to high tensile strain. (Limit is 1% compared to copper cable).

A compliant coating on each fiber protects each fiber from short period bending. Several fibers could be embedded in a single ribbon of compliant material. The fiber optic cable requires sheathing and strengthening members for mechanical strength.

Splicing of fiber optic cables is done by fusing the fibers together and by various mechanical arrangements which hold the ends of fibers together closely and with good alignment.

While analog light signals can be transmitted through the optical fibers, the various applications for communication, measurements, protection and monitoring are interested primarily in Digital Data Transmission through F.O. Cable.

A.12. FIBER OPTIC CABLES WITH TRANSMISSION LINES FOR DATA COMMUNICATION (TELEMETRY)

Application of Fiber Optic Communication is presently in infant stage and has a vast scope due to

1. Freedom from electromagnetic interference (EMI).
2. Enormous Data Handling Capacity of a single pair of optical fiber-cable.

The information is exchanged in the form of digitised light signals transmitted through optical fibers.

Following four methods are available for laying the Fiber Optic Cable with Transmission Lines :

1. Within a hollow tube carried inside overhead earth wire
2. Wrapped around existing line conductor
3. A separate Self Supporting Cable
4. Laid in underground Duct.

Method (1) is used for some new lines. Method (3) or (4) is used for new Fibre Optic Cables to be laid with existing transmission lines. A typical Fibre optic communication channel in Overhead Earth Wire is shown in Fig. A.14. The optical connection are shown in Fig. A.15B.

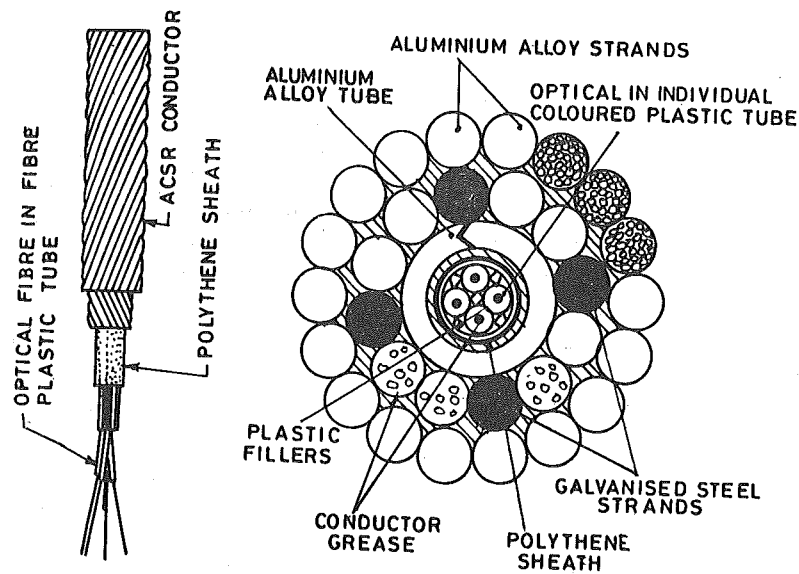

Fig. A.14. Composite earth wire with Fiber Optic Cables in the axis for a long AC transmission line.

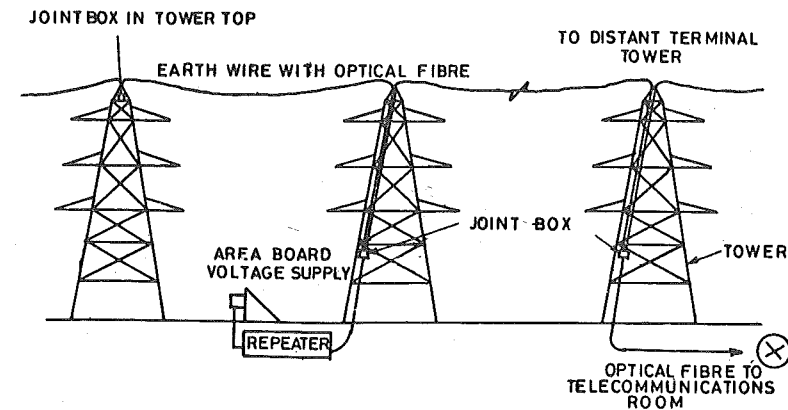

Fig. A.15A. Connections of Fiber Optic Cable with a Transmission Line.

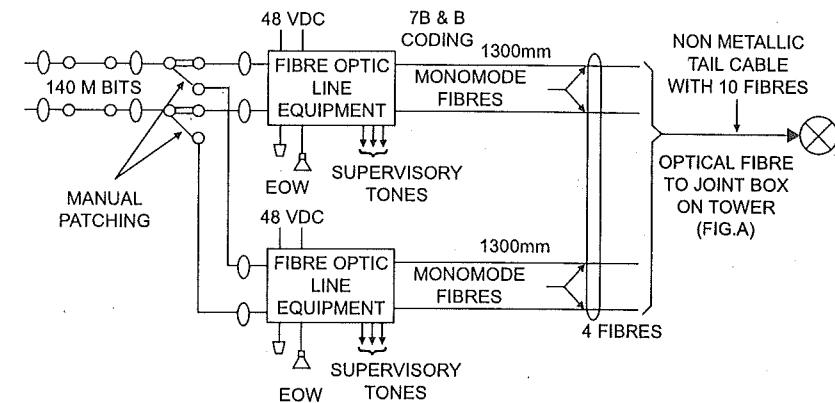

Fig. A.15B. Details of connections of fibre-optic cable in Fig A.15A.

A.13. DIGITAL OPTICAL INSTRUMENT TRANSFORMERS (DOIT)

These include Digital Optical Current Sensors and Digital Optical Voltage Sensors.

A digital optical current sensor system consists of a main conventional current transformer with copper primary, insulated copper wire secondary and fiber optic interface and fiber optic secondary leads between high potential zone and earth potential zone. The secondary insulation is simplified as the fiber optic is a dielectric medium. The burden on main current transformer is reduced. Hence size of main current transformer core is reduced and accuracy is increased. (Accuracy usually corresponds to class 0.2). Fig. A.16A and A.16B illustrate HV DOIT-CT.

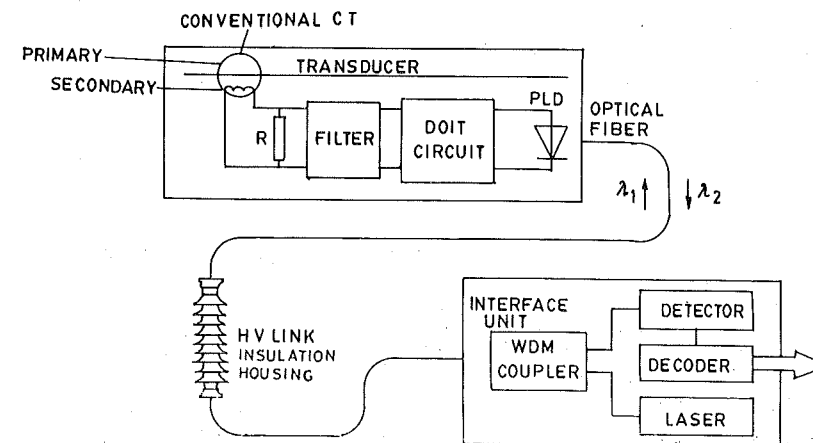

Fig. A.16A. DOIT current transformer system Basic circuit and signal processing principle.

Digital Optical Voltage Sensor is fitted with the conventional capacitor Voltage Transformer (CVT or CCVT). The voltage values are sampled and digitized in a unit fitted to the lower capacitor unit of the capacitor voltage divider. The digitized optical signals are transmitted over the fiber optic link to the measurement, protection, monitoring, control circuit *via* OETP (Fig. A.10).

Intelligent Circuit Breakers for Low Voltage, Medium Voltage and High Voltage Applications

The conventional circuit breakers perform only on and off switching functions. The circuit-breakers of next generation (after year 2000) would have 'intelligence' due to the algorithm provided in the microprocessor located in the operating mechanism cabinet and the operating mechanism cabinet connected to DOIT instrument transformer fitted in the main HV Circuit. The intelligence functions will include

- Communication with back up breakers
- Communication with control room
- Interlocking functions
- Data transmission *via* fiber optic data bus etc.
- Remote switching *via* radio signals

A.14. COMMUNICATION IN POWER SYSTEM NETWORKS

Large quantum of energy flows from various conventional and nonconventional power plants *via* the Transmission Systems. The energy flow is variable, continuous and controlled.

Transmission systems have three principal circuits : (1) Main high power circuit (2) Auxiliary circuits of plant and equipment. (3) Communication and SCADA circuits between Control Centre, Control Rooms of Generating Stations and Substations. Specialised power line/radio communication and SCADA systems have become integral part of Transmission Systems and are used by Power Engineers for effective operation and control of power flow. The requirements and schemes are reviewed in this chapter.

A.14.1. Telecommunication in Transmission Networks

Tele means remote, communication means exchange of information. Telecommunication is the process of exchanging information between two or more locations. Transmission systems need information between Load Control Centre, power station control rooms and substation control rooms, mobile control units in a van for effective control/protection/monitoring/management of the transmission network and energy flow.

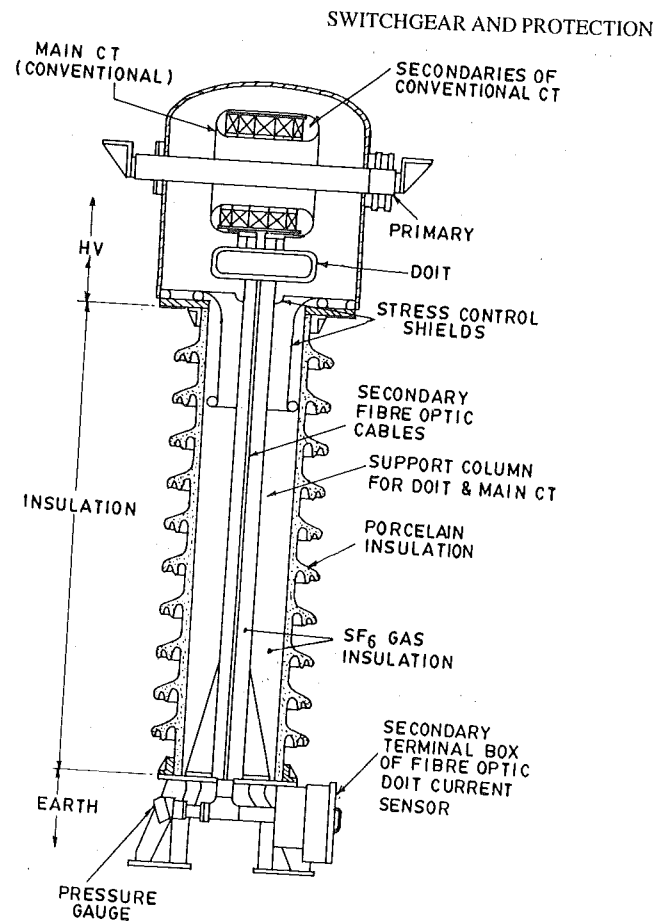

(Fiber optic secondary does not need massive insulation between cable and earth).
Fig. A.16B. Cross section of an outdoor 245 kV current transformer with DOIT

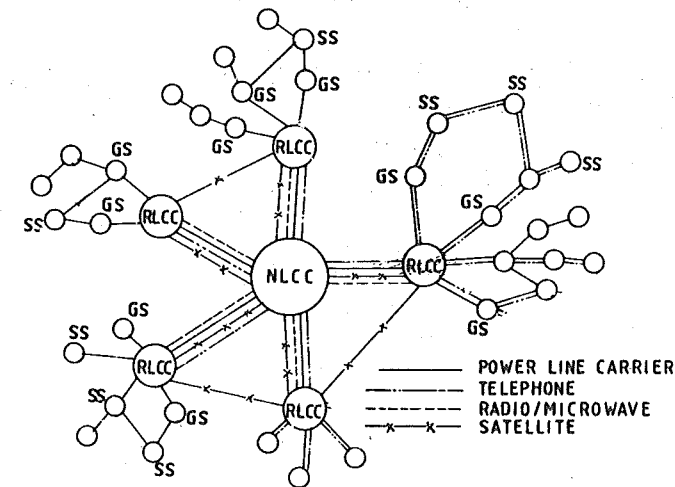

NLCC National Load Control Centre
GS Generating Station
RLCC Regional Load Control Centre
SS Substation

Fig. A.17. Communication channels in energy management system.

Information to be communicated includes :

- direct telephonic talk (voice communication)
- facimile (FAX) transmission of documents
- protection signalling
- SCADA (Supervisory Control and Data Acquisition)
- control signals
- data transmission, electronic mail
- teleconferences, video conferences
- display of network configuration on remote Video Display unit
- Remote control of substations and power stations.
- Artificial intelligence in Power Transmission.

The types of Telecommunication channels include :

1. Communication *via* telephone cables
2. Telephone voice communication via cables
3. Power line carrier communication (PLCC)
4. Radio communication
5. Satellite communication.

The entire power system network is covered by the Communication Channels between

1. Control Centre and Type A Power Stations and Type A Substations.
2. Between Type A and Type B Power Stations and Substations.
3. Between Type B Substations and Type C Substations.

Type A Substations and Power Stations are large, high power, with EHV AC line outgoing from them. Type B and C are of lower hierarchical order. Usually three or more different alternative channels are provided between Load Control Centre, Type A Stations/Substations. (e.g. Radio+Telephone+PLCC). If one of the channel fails, the link through other two channels is available.

Information flow between Type A, Type B and Type C stations is decided by functional needs. For example, carrier protection and intertripping communication may be between two or more Type B Substations, voice communication.

A.15. SATELLITE COMMUNICATION

A type (Major) Power Stations and Substations can be in communication with each other and with Control Centre *via* Satellite. Fig. A.18 illustrates the scheme.

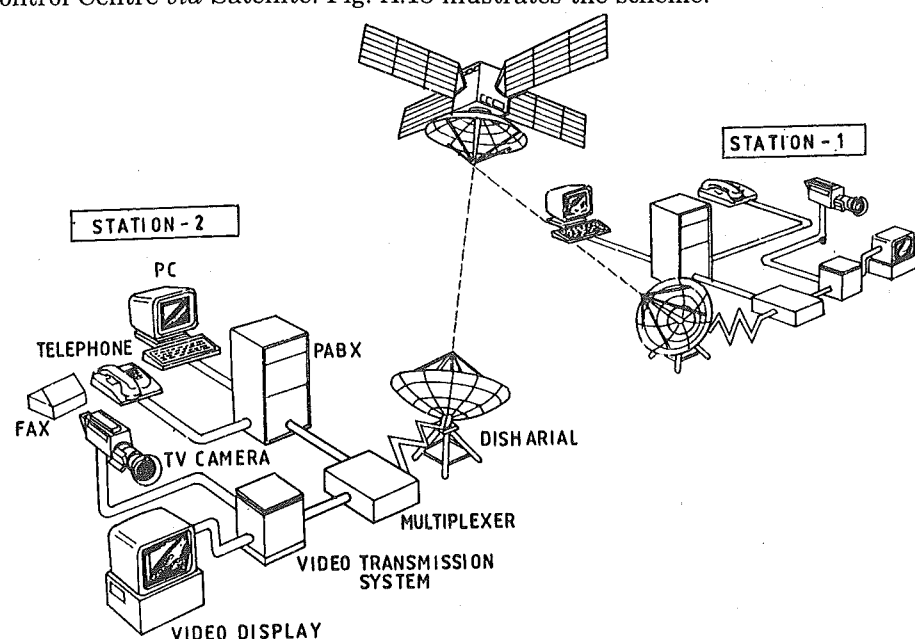

Fig. A.18. Satellite communication between control rooms.

Satellite Communication covers a vast geographical area and is a powerful tool for modern Energy Management System and its High Power EHV AC and HVDC Transmission Network.

A.16. USE OF SOFTWARE IN ELECTRICAL DRIVES

Electrical drive systems account for two thirds of industrial power requirements and they are a central feature of automation systems. The economic potential for saving energy has been largely exhausted as far as the individual components of electrical drive systems are concerned. But there still remains a huge potential for saving energy by improving the design of the overall systems and their dimensioning.

The manufactures of electrical drive systems play a key role in saving energy. AC Induction Motors with various Frequency Drives (VFD) or Variable Speed Drives (VSD) are used mainly for that purposes. Speeds often must change to optimize the process or adapt it to improvement in product quality, production speed or cost. In fact, in electrical power intensive industries like Cement, Glass, Paper, Metal etc. where the electricity consumption forms more than 30 per cent of raw material cost, it is necessary to benchmark unit consumption per ton of final product output with that of best world-class company. AC Variable Speed Drive is one of the many well-known solutions to achieve that goal. If one considers the motor as the muscle, the drive is the brain of the system.

VSD are available for all power levels, from just a few watts up to several thousand kilowatts. These converters have been in the market as a standard product since the middle of the 70's. Control and information electronics were also improved decisively at the same time as power semiconductors. The use of microelectronics is opening up completely new markets both from a technical and economic point of view. The dynamic response of a drive with electronic speed control now meets the highest requirements. VSD are increasingly performing de-centralized process-related automation tasks. The efficiency of today's type of VSD is typically above 96 per cent. In comparison with

conventional methods, electronic speed control can save between 20 and 70 per cent of energy costs. The additional investments for speed control are often already amortized within a few months. Nevertheless, conventional mechanical solutions with higher continuous energy costs or operating costs, respectively, are still being chosen, even today for new installations. The main reason is that companies give priority to keeping initial capital costs down. When pumps, fans or mills are being operated, the flow rates, pressure levels or quantity of material have to be changed according to the requirements of the technological processes. In the case of conventional drives, the motor runs at a constant speed. Quantity reductions required by the process are achieved by conventional control methods (throttle valves, bypass systems or inlet guide vanes) which can lead to very high energy losses. These losses can be considerably reduced by the use of modern drive systems, i.e., drives with electronic speed control. Pumps play an important role here, the reason being that they account for more than half of industrial power consumption for drives. Many pumps are still being operated with the conventional methods. If the speed is electronically controlled, it is no longer necessary to reduce pressure by means of a governor valve and the high eddy losses are reduced to a minimum.

The drives are therefore of central importance when it comes to energy savings. The type of energy-saving method used depends on the application to a great extent. The greater the annual running time of the motor, the sooner the use of expensive energy-saving motors pays off. In relation to the total running time, over 97% of the total costs can be accounted for by power consumption and only 3% by purchase costs. Electronic speed control systems are used wherever the load is dependent on speed. Similar criteria apply to gears and power transmission. Software programs with whose help drive tasks can be planned and improved are available today. To run properly the software it is very essential to know the type of load (Constant Torque or Variable Torque), load inertia, voltage variation limits, maximum speed requirement, acceleration and deceleration time, regeneration, ambient temperature etc.

(i) Motormastert +application Softwares For Drives

The MotorMaster + Energy Savings analysis can be used in several ways. The easiest way to compare the cost of purchasing and powering alternate motors is to compare their simple paybacks. Usually, the shorter the payback period, the more cost-effective the investment. Some industries use a simple payback maximum value of two or three years as a standard by which to make purchasing decisions. There are different sections in the main menu of the software. In the 'List' section, there is the Database of the Motors based on category, purpose of use and manufactures (<http://www.oit.due.gov>).

The decision of replacement/installation of existing motors are done easily by the 'Compare' menu in the main window. There are three possible scenarios for comparative analysis:

- New Motor,
- Replace Existing.
- Rewind

In the mostly used case, i.e., replacing existing motor by an energy efficient one, is done by clicking the 'replace existing' button. In the middle of the left panel labelled "Existing" is a button labelled Inventory, providing access to the Motor Inventory Query screen (the corresponding button in the right panel is labelled "Catalog,") which accesses the Motor Catalog Query screen, the route for selecting new motors from the motors database).

The motor purchase price, installation cost, energy rate etc. are also entered by default or by the user. Now clicking on the 'Savings' button will provide the energy, peak demand and monetary savings associated with replacement of existing inventory motor with a new energy efficient model. The energy use and costs for the existing motor are displayed in the left column while those for the replacement motor are on the right. The Energy Savings screen also displays the Simple Payback on investing in the energy-efficient motor. Click on the Life Cycle button to initiate a life cycle cost analysis. Life Cycle Cost Analysis (LCCA) is an economic decision-making tool for choosing between alternative motors or motor-systems that are intended to serve the same purpose. An

LCCA adjusts for the time-value of money and sums, over a designated study period, all costs related to the owning and operating of a motor-driven system.

The LCCA incorporated into MotorMaster + may be used to analyze a wide variety of energy conservation (or generation) projects. When Life Cycle is accessed from the Energy Savings screen, the motor purchase and installation cost, utility rebate value, annual energy and demand savings, and utility rate information are loaded automatically into the Life Cycle Economics screen. This feature provides the after-tax rate of return on an energy-efficient motor or motor system conservation investment, the net present value, after-tax benefit to cost ratio, and levelized or uniform annual costs of conservation, plus displays before and after-tax cash flows.

The Motormaster + software also manage lot of database like company database and their facilities, departments, processes and the motor inventory. These database may be viewed at their respective screens of the main menu. The motor inventory within a company also supplies 'Motor efficiency status report' which indicates the percentage of energy-efficient motors by population and size, total connected horsepower, and total load serviced. Clicking on the Facility Energy Ranking tab provides a list of facilities assigned to company ranked in ascending or descending order of annual energy consumption, annual energy cost, Energy Use Index (EUI, annual energy use normalized by annual production) or Energy Cost Index (ECI, energy cost per unit of production).

There is also powerful report writing & graphics segment in the software. In the Billing summary report section MotorMaster + indicates the energy consumption and cost, demand and demand cost, and power factor and power factor penalty. MotorMaster + also can display monthly energy use and demand for ALL meters assigned to ALL facilities within a company. In the 'Energy Conservation Summary Report' a list of all Energy Action and Energy Efficiency Improvement records linked to the specified Facility, Department, and Process. The Energy Conservation Summary Report indicates the Energy Action date, title, type of action (motor replacement, rewind, systems improvement or process operating hours change); and the annual energy savings (kWh/year), instantaneous demand reduction (kW), and annual dollar savings. The Energy Conservation Summary report indicates the benefits due to operating your in-plant or company-wide energy management program.

(ii) Asdmaster™

ASDMaster™ software was designed to aid the user in the application of adjustable-speed drives from a total system perspective. ASDMaster™ is a Window based software program consisting of six independent modules. The goal of each module is to automate one of the tasks a plant engineer or technical is faced with when investigating adjustable speed control of an electric motor (Fig. A.19)

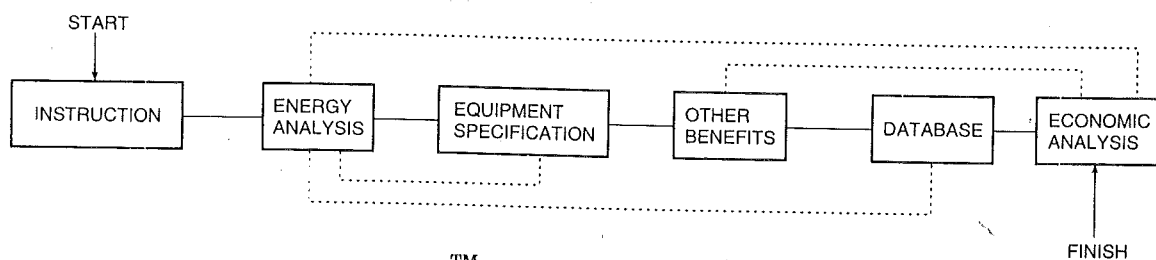

Fig. A.19. ASDMaster™ software Modules (courtesy : ASDMaster™)

Although independent, these modules work together to exchange information. The dotted lines in the illustration below indicate the automated flow of information from one module to another. Although these modules may be completed in any order, the sequence shown here allows the program to automate some tasks that might otherwise require being performed by hand (www.epri-peac.com).

By using the total systems approach to the application and specification of an ASD,

ASDMaster™ maximizes the likelihood of a successful and profitable installation. ASDMaster™ software 'Instruction Module' was created to educate the user in what types of questions to ask relating to the purchase of an adjustable-speed drive (ASD) as the key to creating an effective installation. ASDMaster™ software covers a wide range of topics important to ASD applications like application Fundamentals, Power Quality Basics etc. The 'Instruction Module' also contains several heuristic algorithms which help the user to identify possible power quality and motor problems, and to determine if an application has energy savings potential.

ASDMaster™ software Energy Analysis Module was designed to assist the user in determining the energy costs and benefits associated with various types of adjustable-speed drive (ASD) control. The module computes the energy consumption of both conventional systems and ASD controlled equipment using two different sub-modules.

'Comparative Energy Analysis' sub-module compares the energy consumption of process equipment (fans, pumps, blowers, etc.) under conventional and ASD control.

'Generic Energy Analysis' sub-module is used to compute the energy consumption of most any ASD application, given that the user know something about the driven load. This module is more advanced and flexible. ASDMaster™ software 'Specification Module' automates the task of generating a comprehensive equipment specification for the adjustable-speed drive (ASD) application.

ASDMaster™ software 'Database Module' is essentially a search-engine that allows the user to specify certain parameters (horsepower, speed range, etc.) and narrow a list of stock adjustable-speed drives contained in the database. Users may browse through the drive models and then request a list of contact information for those manufacturers with drives meeting the search criteria.

HONEYWELL VFD ENERGY-SAVINGS SOFTWARE

The variable frequency drive software tool of Honeywell 'NCDrive' is used for commissioning, parameter adjustment, drive control, monitoring & diagnostics purpose. It is basically a commissioning tool for parameterization an application running in frequency converter. We can change the parameter settings in the frequency converter via a PC instead of a panel. Even change of parameter settings can be done in offline mode to save the settings to file for later downloading to frequency converter.

We can even print the parameter settings to paper for archiving purposes. Monitoring up to eight signals simultaneously in graphical format is possible to set triggers which allow to see what happened in frequency converter when trigger fired. We can control the motor by setting the references and commanding the motor to start or stop or change direction by clicking buttons in Operating window. Diagnostic page allows to see the fault history as well as active faults.

There is also a very user-friendly VFD energy savings payback calculator which determines energy savings and payback period based on customer's system demand schedule and variable frequency drive horsepower. The interactive window of the calculator has five easy small steps to get instant idea of energy savings and payback period.

QUESTIONS

1. Discuss the different types of software for AC electrical drives & their specific applications.

Appendix — B

Distribution Management System—Overall System Description

The development of new distribution automation applications is considerably wide nowadays. One of the most interesting areas is the development of a distribution management system (DMS) as an expansion to the traditional SCADA system. At the power transmission level such a system is called an Energy Management System (EMS). The idea of these expansions is to provide supporting tools for control center operators in system analysis and operation planning.

The Power Engineering Group (PEG) of the Tampere University of Technology (TUT) has been studying various issues of distribution networks since the late 1970's. Most of the promising results have been achieved in applying computer technology in different types of design problems. A commercial distribution network information and design system has been developed in collaboration with a software company, Versoft Ltd.

At the end of last decade a new research field was addressed: the application of AI-technology in the operation of distribution networks. So far the research project has been included in two national research programs: "Knowledge engineering in power systems" and "Electricity distribution automation (EDISON)". The aim of the research project was to develop intelligent methods for the operation of medium voltage distribution networks at control center level. The main target was the development of a computer application which is technically applicable in real use. The research focused mainly on the integration of computer systems and the application of intelligent methods.

This report comprises a general description of the development work which has been done at Tampere University of Technology and at Lappeenranta University of Technology as the research project "Information system applications of a distribution control center" of the EDISON research programme. The research group has developed a large number of models and functions for network analysis and operational planning which together form a very advanced DMS.

1. ANALYSIS OF THE DISTRIBUTION NETWORK OPERATION

1.1 The Distribution System

The distribution networks typically include:

- primary substations (main substation or feeding substation) normally provided with one or more 110/20 kV transformers fed by a transmission network
- medium-voltage (20 kV, sometimes 10 kV) feeders
- switching substations along some feeders having only circuit breakers
- distribution substations provided with a 20/0.4 kV transformer
- a low-voltage (0.4 kV) network.

All the 20 kV networks and distribution substations, and most of the low-voltage networks are three-phase. Most of the 20 kV networks are overhead lines due to the need to supply large rural areas; underground cables are used only in urban regions. The 20 kV distribution feeders are operated radially, but are built partly meshed to permit reserve routing. The networks are neutral isolated or resonant earthed systems (*i.e.* earthed *via* an arc-suppression coil). The feeders are protected by a circuit breaker at the primary substation, where constant time protective relays are applied with autoreclosing facilities for overhead lines and instantaneous tripping facilities for very high fault currents. There are no fuses or other automatic sectionalizers along the feeder.

1.2 Distribution Automation

In a wide sense distribution automation covers all automation functions relating to the operation of distribution networks. It includes automation equipment, computer systems, and data transmission technology. Fig. 1 presents a general diagram of a distribution network and the main associated

automation and computer systems. The distribution automation entity consists of many different layers which support each other. The following briefly introduces the main layers:

- *The supervisory level* includes the computer systems of the utility, their integration, interactive man-machine interfaces, and some other appended devices and systems. The main computer systems for network operation running in the control center are the remote control system, the distribution management system, and the load control system.

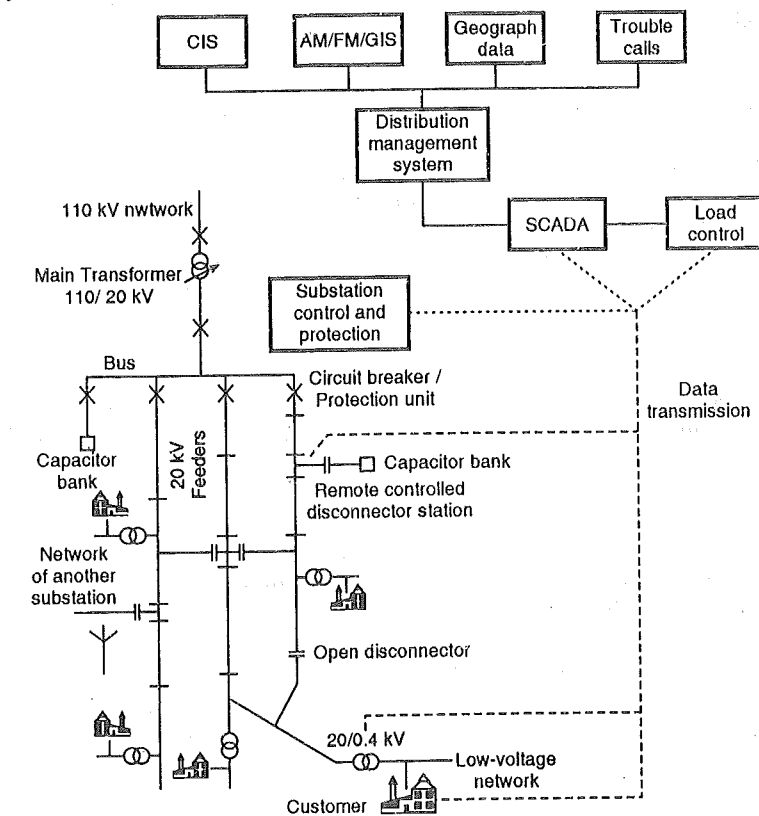

Fig. 1. A general scheme of a distribution network with related automation and computer systems

- *The substation automation* comprises relay protection, different measurement functions, control actions of switching devices, voltage control by an on-load tap changer or capacitor banks, also used to compensation of reactive power, control of resonant earthing; and some local processing capability. Nowadays the μ P-based feeder terminals are an essential part of the substation automation. The feeder terminal may include modules, for example, of an overcurrent and earth fault protection, autoreclosing, and switching control. In addition to providing basic protection functions, the relay can register load and fault currents, the number of faulted phases, time delays, and residual voltage values. The integration of the SCADA system and feeder terminals makes it possible to calculate the fault distance at the control center level and to change the relay settings by the SCADA.
- *The network automation* contains the automation devices along the feeders, including remote controlled disconnectors, fault detectors, automatic sectionalizers, capacitor banks for voltage control and reactive power compensation, and different measuring devices.
- *The customer automation* includes remote metering, direct and indirect load control, other demand side management (DSM) functions, and integration to the building automation.
- *The data transmission technology* deals with the data transfer between different automation functions and systems. The techniques used in data transmission are distribution line carrier (DLC), VHP radio, packet switched radio network, fixed cable, public telephone

network, fiber optic cable, and microwave link. The huge number of objects to be controlled and monitored, the long distances, the need for a fast response time and continuous availability set strict requirements on the data transmission technology. The capacity of the techniques at present in common use will be a bottleneck in large-scale automation.

The most important computer systems for distribution automation and network operation are:

- *The remote control system*, better known as the SCADA (Supervisory Control And Data Acquisition). It contains the remote monitoring and control of primary substations with the data processing facilities. The remote control of disconnectors and the direct load control can be integrated as functions of the SCADA, too. Operations that cannot be remote controlled are carried out by the field crew. These operations are supervised by the control center operator using radiophone communication.
- *The distribution management system (DMS)* is at present the most evolutionary system in the domain. Its importance in supporting efficient distribution network operation has been appreciated. There is still some confusion over what constitutes a distribution management system. DMS is defined in terms of its functions and in relation to other systems. In some senses the DMS is seen only as a function of the AM/FM/GIS or the SCADA when these two systems are integrated, or as an autonomous system encompassing all other systems. The defined applications of the DMS vary, too. But the DMS is defined as an autonomous system, which provides a large number of application functions.
- *The network database system (AM/FM/GIS)* includes versatile and detailed data on the network components (e.g. conductors, switches, distribution substations, poles, and protection). The network components are mapped according to the geographical coordinates. The system is used mainly for network data maintaining and updating, network planning, and monitoring calculations.
- *The customer information system (CIS)* includes data on the customers connected to the network. This data is used in, for example, estimating the loads. Billing is, however, the main function of the CIS.

1.3 The Objective of Distribution Network Operation

The objective of network operation is to minimize the total costs subject to technical constraints. The total operational costs consist of power losses and outage costs. The costs of losses are due to the resistive line losses and transformer losses. From an economic point of view, the active power losses are of great importance.

The outage costs can be seen by the utility or by the customer. The utility costs include the loss of revenue from the customers not served, and increased expenditure due to maintenance and repair, while the costs met by the customer are, for example, such as those due to lost production and spoiled deep frozen food.

The technical constraints of network operation are voltage level, thermal limits, and the operation of protection. The voltage level at every load point must be within acceptable tolerance, for example -10% to +6% of the nominal voltage. The thermal limits of the lines should not be exceeded. The operation of protection must be ensured in all network configurations. The protection must be sensitive enough to operate in every fault and overloading situation but it must not operate due to a load current under the maximum load capacity.

1.4 Operating States and State Transitions

The traditional way to describe the operational states of a power system can be modified to describe better the characteristics of a distribution network. The model is shown in fig. 2. The novelty of the model concerns the normal state. Traditionally the normal state is divided into secure and insecure states based on the security analysis function of the EMS. The distribution feeders are always in insecure state (a fault causes an interruption), which makes security analysis irrelevant in distribution network operation. On the contrary, the normal state can be divided into two parts based on the acceptability of the operational state. The unacceptable state does not contain the disturbed states, which are detected and alarmed by SCADA functions, but only the constraint violations which must be detected using network analysis. These constraint violations include too

low or too high a voltage level in some part of the network and incorrect relay parameter settings. The relay settings may become incorrect when the network configuration is changed so that the smallest possible 2-phase short circuit current does not cause relay operation or the forecasted load current exceeds the overcurrent relay setting. The technical constraints defining the unacceptable state are not unambiguous, which makes the detection of unacceptable states complicated. For example, the lowest acceptable voltage level in the mv-network depends on the voltage drop in the low voltage.

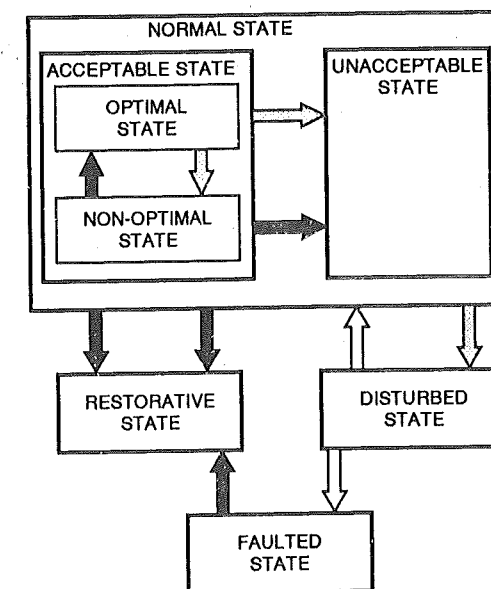

Fig. 2. Operating states and state transitions of a distribution network

The acceptable normal state can be further divided into optimal and nonoptimal normal state. The nonoptimal normal state can be defined as a state where, for example, the network configuration or tap changer position could be changed to reduce the costs significantly.

In the disturbed state the automation system detects an abnormal event in the network and gives an alarm. This can be caused by a fault or exceeding some limitation (e.g. bus voltage). In the faulted state a feeder or part of a feeder has been de-energized and in the restorative state the part of the feeder faulted (or interrupted for maintenance purposes) is isolated and restorative operations have been carried out. It should be noted that the operating states present the current state feeder by feeder, which means that different feeders can be in different states (e.g. one is faulted, others are normal).

Transitions between the states can be caused for several reasons. From the control center operator's point of view the causes are:

- an external factor (gray arrow in Fig. 2)
- automatic operation (white arrow)
- the operator (including moving crew) (black arrow)

An external factor can be a fault or a change of load which causes state transitions that are independent of the operator. A fault causes a transition from normal state to disturbed state. Automatic operations are carried out after the detection of a protective relay, which usually makes a reclosing operation. In the case of successful reclosing, the state transfers back to normal, and in the case of a permanent fault, the state transfers to faulted. A change of load transfers the state between optimal and non-optimal and acceptable and unacceptable. In some cases a change of load causes a SCADA alarm, which means transition to disturbed state.

The other transitions are usually made by the control center operator. These are transitions:

- from faulted state to restorative state
- from restorative state to normal state

- from normal state to restorative state (maintenance outage)
- from unacceptable to acceptable
- from non-optimal to optimal

Some of these transitions may also be automatic, depending on the system (e.g. automatic fault isolation and restoration).

1.5 The Need for New Computer Applications in The Control Center

Nowadays the SCADA is the main (and often the only) computer tool in the control center. The SCADA system collects real-time data from Remote Terminal Units (RTU) using the communication system. The collected data is processed by the control center computer and displayed to the operator. The SCADA system provides a lot of data on the distribution process and gives alarms to the operator. However, the information displayed by the SCADA is often inadequate and several tasks can be determined which are not solved by a conventional SCADA system. The biggest weaknesses of the SCADA are the lack of network maps and diagrams and functions for advanced distribution network analysis (to detect unacceptable states), for optimization and for supporting operations planning. Generally the SCADA system is inadequate because there is not enough information to be processed.

Because of the inadequacy of the conventional SCADA system some cumbersome tools like mimic boards and paper maps are used to support the network operation. There might also be some written instructions for special cases (e.g. primary substation failure) and calculation programs for simulating the network state. However, these programs are designed not for operational purposes but for engineering analysis and network planning. The operations planning is mainly based on operators' experience, knowledge and intuition.

Because of the insufficiency of the SCADA and use of cumbersome supporting tools, there is an obvious need for new computer applications in the control center. But there are also some other trends making new applications necessary. The overall importance of the distribution networks, especially at the medium voltage level, is increasing. The slowing down of load-growth has often made network reinforcements unprofitable, which means that the existing network must be operated more efficiently. At the same time larger distribution areas are for economic reasons being monitored at one control center and the number of operation staff is decreasing. The requirements for the quality of supply are also becoming stricter. These problems can be managed better using advanced applications.

Within the normal state system analysis is needed to estimate the electrical state of the feeders. The data obtained from the SCADA is not alone sufficient for real-time monitoring of the state of the distribution network as a whole, since detailed data on network components and the load distribution along feeders are not known. A distribution network oriented state estimator combining load modeling with remote measurements of the SCADA is needed for real-time system analysis and short-term load forecasting. This analysis can be used in the detection of an unacceptable state and the simulation of network configurations. A supporting planning tool utilizing load forecasts is needed for remedial control, optimization of the network configuration and planning of maintenance outages.

In a fault situation fast fault location is essential in reducing the outage time and costs, while permanent faults have traditionally been located by time-consuming and troublesome experimental switchings. Mostly the annual outage costs are accumulated during the time taken to locate and isolate the fault. The integration of different computer systems and automation devices, and new software methods give potential for developing new tools for use in fault management, further reducing the outage time and improving the quality of supply using the existing or less manpower. The greatest benefits are achieved by the methods which are able to tell as accurately as possible where the fault is situated along the feeder, where the fault definitely is not, and what kind of switchings should be done, either automatically or manually. The known location of the fault makes it possible to quickly isolate the faulted section and to restore the unfaulted network by back-up connections, where they exist.

2. COMPUTER SYSTEM INTEGRATION

The need for new applications is obvious and the potential for developing them rather good. The data needed is mainly available in some existing systems. A number of methods for modeling and calculating distribution network have been developed and the computer capacity is nowadays

sufficiently efficient and inexpensive. The solution is to have a large amount of data to be processed and some new methods to provide the applications needed.

In order to model and analyze the distribution network and operations, data on the network topology, components, loads, measurements, switching states and fault events is required. The advanced display of the network and results of analysis further requires geographical data and a geographical map.

The new applications could have an independent database for the required information created and maintained by the system engineer. However, this strategy would not be reasonable for the following reasons:

- most of the data needed is found in the other databases of the utility
- the updating cycle is very frequent
- the number of data objects is very large

Data consistency in the information systems of the utility is very important and can be ensured only by providing a single entry for each data. Additionally, the control center systems can no longer be isolated from the other departments, since the control center is an important part of the data flow chain of the whole utility. The senior corporate personnel, customer service and network planning departments all need access to real-time operational data and operational statistics to know the status and bottlenecks of distribution network operation.

For the above reasons, the computer systems of a utility must be integrated. Two integration approaches are being applied in distribution automation; the vertical and the horizontal. In vertical integration different automation layers are seen hierarchically so that each layer carries information upwards (e.g. from substation relays to the control center SCADA). The general trend is to apply intelligence at as low a level as is reasonable. Horizontal integration means an open architecture and the use of a data transmission network between different computer systems.

The main data source for the new applications in the control center is the AM/FM/GIS system, the database of which contains the necessary data on the network (nodes and branches) and detailed data on network components (lines, disconnectors, substations, transformers). The data of the AM/FM/GIS can be used to provide a static model of the distribution network for the control center application. The SCADA system provides real-time data on primary substations and some telecontrolled switches in the distribution network. The data needed by the new applications includes the switching status of disconnectors and circuit breakers, the feeder current and weather measurements, relay information, and the state of fault detectors. The CIS database includes data on customers' energy consumption and customer groups. That data is required to provide source data for load flow calculations.

Regarding the new applications there are several alternatives for implementing the computer system integration. A widely used approach is to embed the new functions in some existing computer system, SCADA or AM/FM/GIS. The data to be transferred depends on the integration strategy. In the SCADA oriented system the network data and geographical maps are transferred from the AM/FM/GIS system. If the AM/FM/GIS is enlarged to a control center application, the real-time data is transferred from the SCADA system.

In both the above strategies the new functions are embedded in some existing computer system. This means strong dependency on the vendor of the existing system. An alternative strategy is to develop an independent system which is integrated in other computer systems using well-defined interfaces. This approach makes it possible to use the new system in various computer environments, having only weak dependency on the vendors of the other systems. The weakness of this approach is that the separate system requires more information to transfer from other systems, this alternative is preferred and has been used in developing an independent distribution management system (DMS).

In the above integration strategy the DMS forms a junction of the two approaches, vertical and horizontal integration, as seen in fig. 3. The DMS applies horizontal integration and open architecture with various databases and information systems, and has a real-time connection to the SCADA. The communication technique provides the vertical integration in a very wide sense—a channel to the distribution process via the SCADA, to the customers via a telephone answering machine and to the field crews.

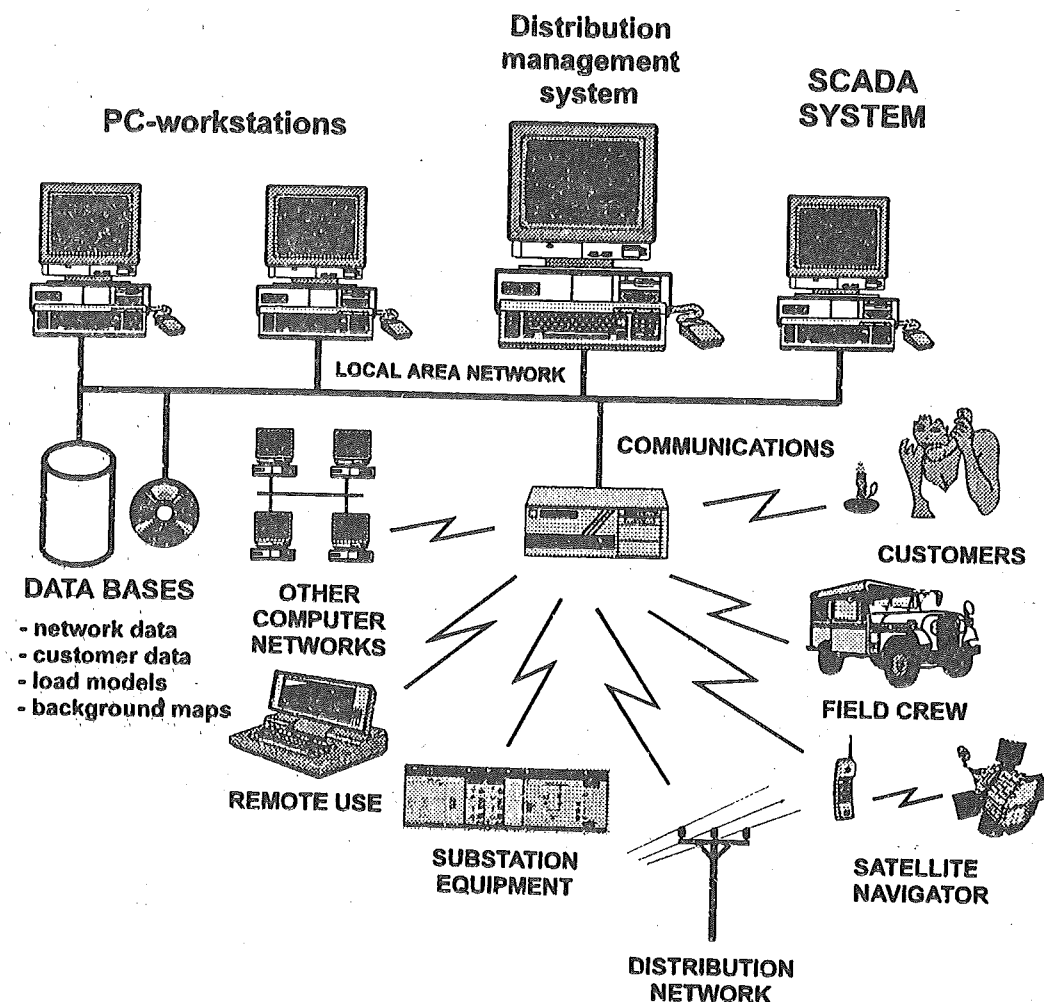

Fig. 3. The integration of the DMS.

The idea of open system architecture makes the integration of the systems of different suppliers feasible. However, the SCADA and AM/FM/GIS systems are rather complicated and case-by-case specialized so that the transition to a real open architecture is difficult. However, with new techniques like Open Database Connectivity (ODBC) and standard user interfaces the open system architecture is more easy to utilize and the differences between the integration strategies are disappearing.

3. THE DISTRIBUTION MANAGEMENT SYSTEM

This section describes the basic models and functions of an intelligent distribution management system, which has been jointly developed by the distribution automation group of the Tampere University of Technology, software companies, and distribution utilities. Distribution management system (DMS) will henceforth mean the system described here, unless otherwise stated. The description can also be seen as a definition of a system for other developers. Therefore the implementation of the system is discussed in the next section.

3.1 Overall Description of the System

The structure of the DMS is illustrated in fig. 4. The system consists of five layers—user interface, application functions, models and computation methods, data interfaces and external systems and data sources.

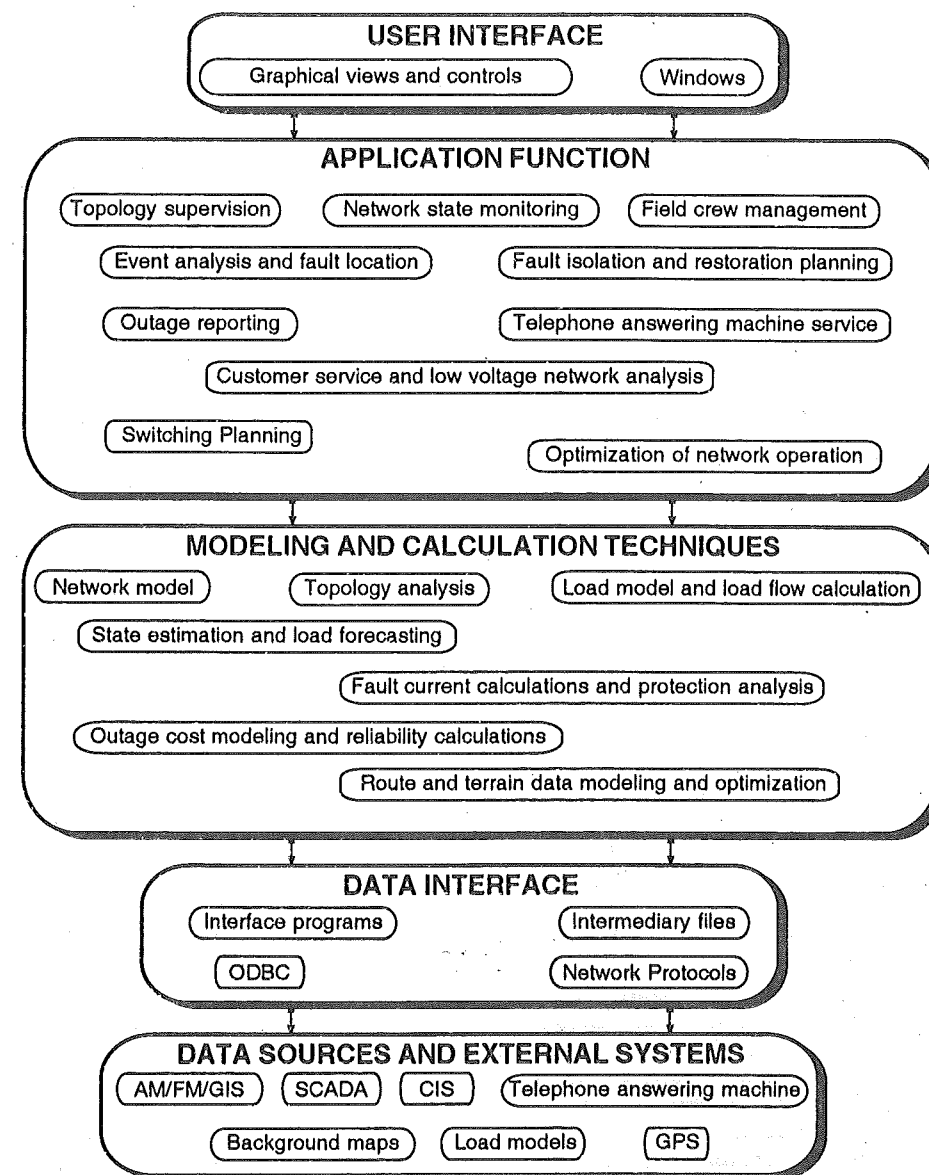

Fig. 4. The layers of the DMS.

The basis of the system is flexible integration of the DMS and external systems and data source. The data interfaces separate the external systems and sources from the DMS and makes the DMS independent of the vendors of the external systems and data sources.

The DMS provides a large number of different modeling and calculation methods, which are described more in the next section. These models and methods form the basis for the intelligent application functions of the system.

From the user's point of view the user interface (UI) is a very important part of the DMS. A basic requirement is a standardized graphical UI including multiple windows, mouse control, color graphics, and explanation texts. The basis of the user interface is a geographically formed network image on background maps. The scale of the viewed background maps depends on the zooming scale. If a large network map is viewed, the background map is part of a large-scale map, and for a small-scale zoom, a map with high resolution is used. The DMS also uses audio alarms in case of faults or constraint violations giving information on the reason for the alarm.

The network image has active mouse functions for zooming, selection and diagram generation. The diagram has active functions for changing the switching status, network tracing and checking the numerical member variables. The colors in the network image visualize the inference and calculation results. The graphical views are supplemented by text windows to inform the user. The information can be results, instructions and warnings. The useful output are the geographical names of network components like disconnectors and distribution transformers in addition to the numerical codes of the devices.

One advantage is that the DMS provides the same common graphical user interface for different purposes (e.g. for the answering machine).

3.2 Modeling and Computation Techniques

3.2.1 The Network Model. The core of the DMS is an object-oriented network model which represents the real-time or simulated state of the network. The main objects are line sections and different kinds of nodes. A node can be a disconnector, busbar, circuit breaker, branching point, etc. The static topology of the network is modelled by "is connected to" relations of the objects and the real-time topology is modeled by dynamical "is-fed-from" relations. The objects also have data members to model the static (line type, coordinates, etc.) and dynamic (voltage, power, switching status, etc.) component data. For deeper network analysis the objects of one part of the network can be expanded dynamically using the direct access from object to additional data (e.g. terrain conditions of a line).

The memory-resident network model provides a high-speed computational capability for real-time application. The object-oriented modeling technique makes it possible to use knowledge based (heuristics, fuzzy reasoning) methodologies in the application modules of the system.

3.2.2 Topology Analysis. Topology analysis, load flow and fault current calculations are the starting point for the network analysis and optimization functions. The topology analysis function uses the static network modeling and dynamic switching status information for connectivity analysis and to construct a real-time network model. The static network model includes all constructed lines and transformers, and real-time information on the states of breakers and disconnectors is used to construct the radial feeders. Mainly because of fault current protection, partially looped medium voltage networks are operated radially. Thus it is quite simple to detect abnormal or erroneous switching states causing de-energized line sections and substations or closed loops. The determined cold line sections, i.e. line sections without voltage, and the feeders that are meshed are displayed on screen to help the operator to detect the errors in the switching state.

3.2.3 Load Models and Load Flow Calculation. In the DMS the load models of customer groups are obtained separately and included in the system. The DMS uses the hourly load models covering each hour of the year and including loads for special days like Diwali, Christmas and New Year's Eve. The models can easily be adjusted for each year's calendar so that the first day of each year is the right day of the week and the special days are in the right position. These hourly models present the expected demands and standard deviations directly as powers (kW). Load-temperature dependences for each customer group and each month are modeled using linear regression. The temperature factor is presented directly as $\text{kW}/^\circ\text{C}$. All the values are presented using a suitable annual reference energy for each group. In this way the loads for each hour of the year are presented in a meaningful range.

Using these models the vital information, which the electric utility should have, is the annual energy, location in the network, and type of customer. In practice most utilities do not so far have enough information about their customers to utilize all the load models. Instead the more general classification to 15 groups can be used.

The load flow calculation of a radial network differs from calculation of a looped network. The developed load flow procedure uses the objects of the network model but for the sake of efficiency it is not completely object oriented. However, the objects store and validate the input values of the load flow. For example, real-time load flow calculation uses the measured busbar voltages at the primary substation as input data. The measured value received from the SCADA is vulnerable to errors in data transfer and cannot be used directly without validation.

Because the load models for 46 customer types present the load as a random variable using Gaussian distribution, the effect of randomness and uncertainties can be considered statistically in

load flow calculations. Calculation with normally distributed random variables is not too difficult, since normal distribution has only two parameters, i.e. the expected value and standard deviation. When the loads in all nodes of the network are presented as random variables, the load flow calculations can be performed using the statistical confidence limits (e.g. 10% excess probability) needed to check violations of the technical constraints. The load currents and voltage drops could be calculated as random variables, but this would cause quite complicated equations. In practice it is better to use the loads of some predetermined excess probability and to calculate corresponding load currents and voltage drops in the network.

To get the best possible load flow results the load models for customer groups have to be extended to include power factors and load-voltage dependences. The power factors are needed to calculate accurately voltage drops in the network and to analyze the effects of reactive power compensation by capacitors to power losses. The load flow calculation allows modeling loads as voltage-dependent. Voltage dependences are needed especially to study the effects of voltage regulation on the electrical state of the network. The dependences of active and reactive power are modeled for each customer group.

3.2.3 State Estimation and Load Forecasting. Because in operation planning it must be possible to carry out the network calculations in any real or simulated network configuration, the loads of distribution substations must be estimated and a load forecast must be available for each distribution substation. In state estimation the load flow results, i.e. the sum of substation loads plus losses, are compared with the load measurements available at least at the primary substation (110/20 kV), where the load currents of feeders and the voltage in the busbar are measured. In this case redundant information on loads is available and weighted in least squares; estimation can be used to estimate the loads for distribution substations more accurately. The standard deviation of load measurement (standard error) as well as the standard deviations of the modeled loads are used as weights in the estimation. If several measurement points along a feeder are available, these define new sections for estimation and can be treated separately for additional accuracy.

The state estimation results are used to form dynamic load models for distribution substations, which in turn are used to determine the final load forecast when the temperature forecast is available. The dynamic load model for a distribution substation includes loads for the next week, i.e. for the next 168 hours. A dynamic load model for a distribution substation is formed by adjusting the load calculated by the static load models of different customer groups by the average ratio of the estimated and modeled loads calculated in the state estimation of the respective hours during the last two week period. The load presented in the monthly normal temperature and the temperature dependency of the load of each substation calculated separately are stored in a database. In this way the load forecast can be calculated using the latest temperature forecast, or worst case analysis can easily be performed by setting a very low (or high) value for the temperature. When the system is connected real-time to the SCADA, state estimation is performed at least once an hour and the dynamic load models of substations are updated. Every hour forecasts for the next week's respective hour are updated and a one week load forecast is thus constantly available.

3.2.4 Fault Current Calculation and Protection Analysis. In addition to load flow calculation, fault current analysis is needed to check the acceptability of the network operation. With relay information the protection can be analyzed to ensure the acceptability for monitoring and planning purposes. The fault current analysis is also used in the determination of fault location.

The voltage value along the feeder based on the load flow results is used in the short circuit current calculation of every network object. The earth fault current (isolated neutral or resonant earthed system) is calculated at one time for all feeders connected to the same primary transformer.

3.2.5 Outage Cost Modeling And Reliability Calculations. Switching planning, for example, requires detailed analysis of the outage costs. The outage costs can be seen by the utility or by the customer. In the DMS the costs of the customer are considered so that the benefit of decreasing the outage times will economically accrue to society.

The evaluation of the outage costs met by customers is based on the value of non-distributed energy. The value of non-distributed energy can be over one hundred times greater than the value of distributed energy. In the DMS the hourly outage cost parameters (constant and time-dependent outage cost values) for each distribution transformer are maintained in addition to the load forecast.

Outage costs are usually nowadays utilized in the reliability calculations of a distribution network as one part of the long-term planning process, in which the average annual reliability indices are studied. In the DMS the outage costs are used to determine restoration priorities and in calculating the sum of expected hourly outage costs in the network as an operational reliability index. In the reliability calculation each feeder is analyzed zone by zone. The expected failure rate of the zone is calculated and the resulting outage duration of each of the other zones of the feeder is analyzed. Using the hourly outage cost values of the load points, the total expected outage costs of a feeder and the whole network can be calculated.

3.2.6 Road And Terrain Data Modeling and Route Optimization. For manual operations (e.g. disconnectors) the moving times must be determined because they can vary quite considerably. The bee lines between network devices in rural areas can be long and the real route can be many times the bee line, especially in lakeland. The geographical database is utilized in calculating the moving times. Based on the road network data, an object-oriented model is generated, which consists of road section and crossing point objects and the relations between them. Road sections are classified into five types and each type has its own traveling speed and transition time. The road network model is utilized in optimizing the routes and calculating the moving times of the crew. The fastest route between two points is sought using Dijkstra's algorithm.

The terrain conditions of overhead line sections have been stored in the geographical-database. Each line section knows if it is in a forest, field or swamp, if there are trees on only one side of it, if it goes through a forest island in a field, and the height above sea level. The terrain conditions are used in inferencing the possible fault locations.

3.3 Functions

The DMS provides an extensive group of intelligent functions to support the distribution network monitoring, fault management, operations planning and optimization. The whole operation of the DMS from the functional point of view is interactive so that the operator is responsible for performing the operations by remote control or by advising the staff.

3.3.1 Topology Supervision. The network topology supervision function is the basis for all other applications. Using the function, the conventional mimic boards and paper maps can be replaced by the display of the DMS. The positions of the remote controlled switches are obtained from the SCADA system and the states of the manual switches are updated manually to the DMS using the field crew information. In addition to switching state information, a line stump can be set as open in the network model of the DMS. Using the switching state information the actual network topology is analyzed by the DMS. The search is based on the depth-first strategy and "is-connected-to" relation of the objects. If there are any closed loops or de-energized load-points in the network, the DMS gives an alarm.

The network topology is presented on the screen using different colors to distinguish line sections supplied by different feeders or by different primary transformers. The de-energized line sections are shown in white and the loops are shown in red.

The main network representation is based on geographic network maps. A small window is used to provide an overview of the whole network and a large one for zooming. In the larger window the network map is combined with the background map. To clarify the schematic details of the network, the user can select a location for which a local diagram is generated dynamically and displayed on the screen. By pointing a line section in the diagram the downstream network (the line sections fed by the selected line section) is traced on the geographic network view. An example of the user interface of the system is shown in fig. 5.

3.3.2 Network State Monitoring. Hourly state estimation is performed to monitor the electrical state of the network and to check whether the state is acceptable or not, i.e. whether any technical constraints are violated in the network. As a result of the state monitoring function, all line sections where short circuit currents, voltage or load currents violate or are near to violating specified constraints are always presented color-coded on screen. This applies also to de-energized line sections and substations. The user can choose whether he wants to look at voltages, loadings or losses per kilometer more accurately, i.e. each line section of the network. The limiting values for warnings and alarms can be adjusted by the user and the operator has the last word on whether the state of the network is acceptable or not. In each case the warning level is illustrated using a thick

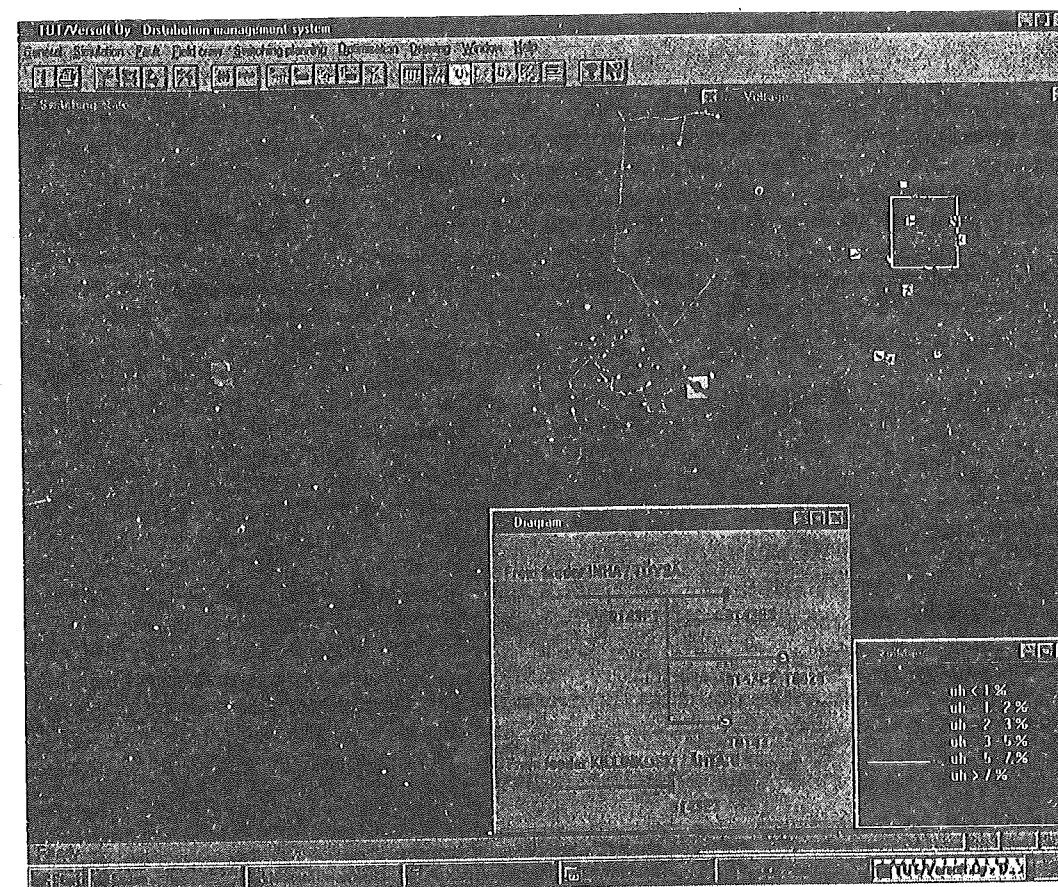

Fig. 5 The user interface of the DMS

yellow pen and the alarm level using a thick red pen. The DMS also uses alarm lists and audio alarms giving information on the reason for the alarm. Standard windows compatible audio cards can be used. By pointing the mouse the user can also look at the supply voltage and loading of any distribution substation.

To keep the network in an accepted state all the time, the state monitoring can be done in advance using the load forecasting results for distribution substations and temperature forecasts. Forecasting the state is especially important during expected peak hours of the year in order to plan the corrective action that may be required. In the absence of good quality temperature forecasts, the user can input a 'worst-case' value for the forecasted temperature to study the state of the network in extremely difficult conditions.

Planning the remedial controls needed to remove the constraint violations is supported by an interactive process activated by the detection of constraint violations. The user switches to simulation (study mode) and chooses one remedial control alternative and the system analyzes the effect of the control and displays the results. A successful result needs one or several loops. In voltage or load capacity problems the possible remedial controls are voltage regulation, switching of capacitors, changing of open points and load-shedding in extreme cases. The protection problems can be removed by changing the relay settings or the open points of the network.

3.3.3 Field Crew Management. The field crew management function of the DMS provides a tool for supervision of the working groups and optimization of the driving routes. The working group information needed is stored in a crew database maintained by the DMS. The crew data includes, for example, persons, the vehicle and location of the group. The location of the group is pointed on the geographic map on the screen or obtained from the global positioning system (GPS).

The field crew location data is used in switching planning functions of the system and interactively in seeking, for example, the nearest group to a specific task.

3.3.4 Event Analysis and Fault Location. When a distribution system transfers from the normal state, the SCADA obtains information from the process. In the case of a permanent fault, the primary system transfers to faulted state and operations are needed.

The basic event analysis is made by the protective relay, other substation automation and the SCADA system. In this analysis the faulted feeder, the type of fault (earth fault, 2-phase short circuit, 3-phase short circuit); the measured fault current and detected fault indicators are determined. In some cases deeper analysis is needed by the DMS to detect the possible malfunctions of the protective devices and concurrent events. The analysis is also used to produce an assumption of the cause of the fault (e.g. arc, fallen tree, etc.).

In a fault situation the available data is transferred from the SCADA via the LAN to the DMS, which forms a deeper object model of the faulted feeder and infers the possible fault locations. The sequence from the opening of a circuit breaker caused by a fault to the feeder figure on the DMS screen illustrating the possible fault locations is carried out automatically without any operator actions in about 10-30 seconds. In locating a feeder fault the application combines the component and terrain data of the faulted feeder, an estimate of the fault distance, information on the operation of fault detectors, measurements, the prevailing weather conditions, and the heuristic knowledge of operators. In short circuit faults the calculated fault distance is the main information used in the inferring. The electrical distance between the feeding point and the fault location is determined by comparing the calculated fault currents with the measured short-circuit current and the type of fault, which are registered by uP-based protection relays. The possible fault locations are ranked using information on other sources (e.g. fault detectors, terrain conditions, weather information). Fuzzy sets are used to model the knowledge and information as various membership functions in the inference model. By combining the fuzzy sets, alternative fault locations can be achieved and arranged according to their feasibility based on all the available information on the fault situation.

3.3.5 Fault Isolation and Restoration Planning. Confirmation of the fault location is obtained by interactive experimental switching measures to isolate the faulted line sections. The planning of these operations is assisted by the DMS. The isolative switching operations are performed in two phases; first by remote controlled disconnectors and then using manual operations. The possible fault locations and likelihoods that disconnector zones include the fault are used in the switching planning. If one fault location or faulted remote controlled zone is clearly the most likely one (e.g. all the remote controlled disconnectors are provided with tele-monitored fault detectors and the fault distance is known), the faulted remote controlled zone can be determined quite easily without any unnecessary switchings and opening of the circuit breaker. If there are no fault detectors along the feeder and the fault distance is unknown (e.g. in earth faults of neutral isolated networks), the switching planning problem is more complicated. The rule-based inference model based on the "zone by zone rolling" strategy has been developed for this issue. In this method remote controlled zones are checked one by one according to the feeding direction. The method is applicable because the switchings are accomplished rapidly using remote controlled disconnectors and only one opening of the circuit breaker occurs during the fault location before the faulted remote controlled zone is detected.

The DMS includes two inference models for the planning of manually operated switchings. The first model uses the bisection strategy. The other and more advanced model is based on the minimization of the expected value of the outage costs of customers in the prevailing load conditions. The moving time of the working crew is also taken into account.

The DMS proposes the switchings to the operator or switches the remote controlled disconnectors automatically. As a result of an experimental switching, the system knows one or more zones which do not include the fault. These zones can be restored during the fault location.

The last immediate operation needed in faulted state is restoration of the supply of interrupted customers. The restoration planning can be made interactively or independently by the system. In the interactive mode the system gives relevant information on the outage areas and back-up connections and proposes the best alternative, but the user can choose another one. The impact of the chosen operations on the network is analyzed and the constraints are checked. The interactive process continues until the successful goal is reached. Like fault isolation, the restoration operations

are carried out in two phases. Thus remote controlled restoration operations are performed before manual fault isolation operations.

The search for the best alternative is carried out using heuristic model-based inference. The outage areas are restored in order of importance determined according to the outage cost. In the remote controlled phase the back-up connection with the largest remain capacity is preferred and in the manual phase the fastest (based on moving time) manually operated one with sufficient capacity is preferred. If one back-up connection is not sufficient, several back-up connections or load transfers are used, and in the last alternative the customers with the lowest outage costs are not restored.

3.3.6 Outage Reporting. When the fault has been repaired and the network has been returned to the normal state, the operator makes a report on the fault. The DMS offers tools for fault reporting. The application determines and fills in some reported issues automatically while the others are filled in by the operator using dialog boxes. The calculation of the values describing the extent of the fault is a valuable support for the operator. All the switching actions during a fault situation are automatically stored in a file. Using these switchings, the DMS can later simulate the network restoration. The application takes switchings one by one, calls the network configurator, and determines which distribution substations are without electricity. The task is to infer the outage time of each distribution substation. For each outage part the fault management application calculates the number of disturbed distribution substations and associated hours, the number of disturbed customers and associated hours, and the amount of non-delivered energy. The information on the outage parts is shown in a separate dialog box. The calculated values of each distribution substation are stored in a database so that the values can be studied over a period of one year. Thus the real annual outage time of a distribution substation and a certain customer is known. In addition to the fault situation the reports can be created from maintenance outages.

3.3.7 The Telephone Answering Machine. In a fault situation customers call the control center to report that they have no supply. Most of the calls simply mean additional work and are a waste of the operator's time in MV-feeder faults. A call is valuable only if a customer knows the exact location of the fault. An automatic telephone answering machine therefore means better customer service and gives the operator more time to concentrate on fault location and network restoration. The DMS is used to tell the answering machine how to answer depending on the outage situation.

In MV-feeder faults the initial fault information is created automatically without any user actions. The information is updated by the operator through the user interface of the DMS. When a customer dials the trouble call number of the utility, he/she hears a real voice stating the reason and the range of interruption, and the phase and expected time of restoration. If the customer has some important information (e.g. he/she knows the fault location), he/she is asked to dial another number, where the operator answers. In the case of a fault in a low-voltage network, the answering machine informs that there is no fault in the MV-network, asks the customer to check his own fuses, and requests him to dial the other number to reach the operator. Once the first customer has called and the faulted low-voltage network has been confirmed, other customers affected by the same fault calling later are informed by the answering machine. A maintenance outage resembles the MV-feeder fault situation with the exception that the operator forms the primary information.

3.3.8 Customer Service and Low Voltage Network Analysis. To enhance the customer service of operators and other personnel the DMS includes customer information transferred from the customer information system. One main target is the location of a customer calling the control center. The operator has a list of all customers on the screen and he can choose the calling customer according to his name. The DMS immediately shows on screen the distribution substation feeding the calling customer and the operator can see whether the substation is supplied or unsupplied because of an outage in the MV-network. Further, the operator can choose the distribution substation and switch to the presentation of the low voltage network where the exact location of the customer is shown.

Each time the voltage levels are shown on screen an approximative analysis of voltage level in each low voltage network is performed. The analysis utilizes the monitoring calculations of the LV-networks and load models of the specific hour. Further state estimation results of the MV-network are used. The voltage level in the MV-network and the real-time demand of the distribution substation are used to calculate the lowest voltage level at customers. As a result, each distribution substation where the lowest voltage is less than 90% of the nominal voltage is shown on screen in red, the general alarm color of the DMS.

3.3.9 Switching Planning. In addition to the switching operations planning during faults, the DMS provides an advanced tool for generating switching plans for maintenance outage purposes. The outages are required in, for example, the scheduled maintenance of a primary transformer or a change of cable.

In the switching planning for maintenance outages the principles are mainly the same as in restoration by manually operated disconnectors. The planning can be interactive or independent. After a successful planning process the system generates the switching sequence.

Unlike the restoration planning, the maintenance outage planning is not time critical. The plans can, for example, be generated a day before the maintenance. In the DMS the generated plans can be saved and retrieved for execution. In the LAN environment the planning and operation can be located in different places. Once the maintenance is finished, the DMS assists in generating the required outage report.

In the emergency state of a bulk power system there is sometimes a need for load shedding to prevent the system's collapse. The DMS provides two planning models for load shedding, one for feeders and the other for all remote switches. In both models the idea is to seek a switching sequence which accomplishes the required load shedding (10%, for example) with minimum outage costs to the customers.

3.3.10 Optimization of Network Operation. In optimizing the network operation the objective is to minimize the total costs of network operation subject to the operating constraints. Possible measures are changing the open points of the network, controlling the voltage by on-load tap changers and capacitors. The heuristic optimization is based on the real-time and forecasted network calculations and can be interactive or independent. The independent optimization can be activated automatically, for example, once an hour. The result of optimization is a proposal for optimizing operations.

There are several alternative ways of carrying out network reconfiguration functions. The objective can be loss reduction or reliability improvement. The loss reduction method can be applied using either all the switches or only the remote controlled switches and the reliability improvement method only by remote switches. The progress of the reconfiguration is illustrated by a curve, which shows the reduction of the objective function. The final result is the achieved numeric improvement and the switching sequence.

Since the estimated and forecasted loads include load-voltage dependences, the user can simulate a change in the selected busbar voltage. In the case of peak clipping, the DMS displays the reduction in the total load of the substation and the voltage level in the network after voltage reduction. In the other case the DMS searches the highest busbar voltage causing no overvoltage to any customer and displays the change in total load and losses.

4. IMPLEMENTATION

This section describes the practical implementation of the DMS. The development platform is presented and the integration and data interfaces are described.

4.1 The Development Platform

The implementation history of the system is based on prototyping technique. The first implementations were made using a lisp-based expert system shell in a PC environment. The development focused on knowledge-based problems (fault location, restoration) and the user interface. The first prototype was too slow for real testing, but the basic implementation principles (mainly the object-oriented programming) and the ideas of the developed inference models were proven to be suitable for the next prototype. In 1992 C++ was chosen as a programming language and in 1993 Microsoft Windows was selected as an operating environment. In graphical user interface programming Microsoft Foundation Classes (MFC) libraries are used.

The development platform at TUT consists of the DMS-PC (with Microsoft Visual C++), S.P.I.D.E.R. MicroSCADA and substation automation (feeder terminals and RTU) by ABB Transmit Co., and AM/FM/GIS by Versoft Ltd. The data interfaces have been developed in cooperation with ABB Transmit Co. and Versoft Ltd. The platform is illustrated in fig. 6.

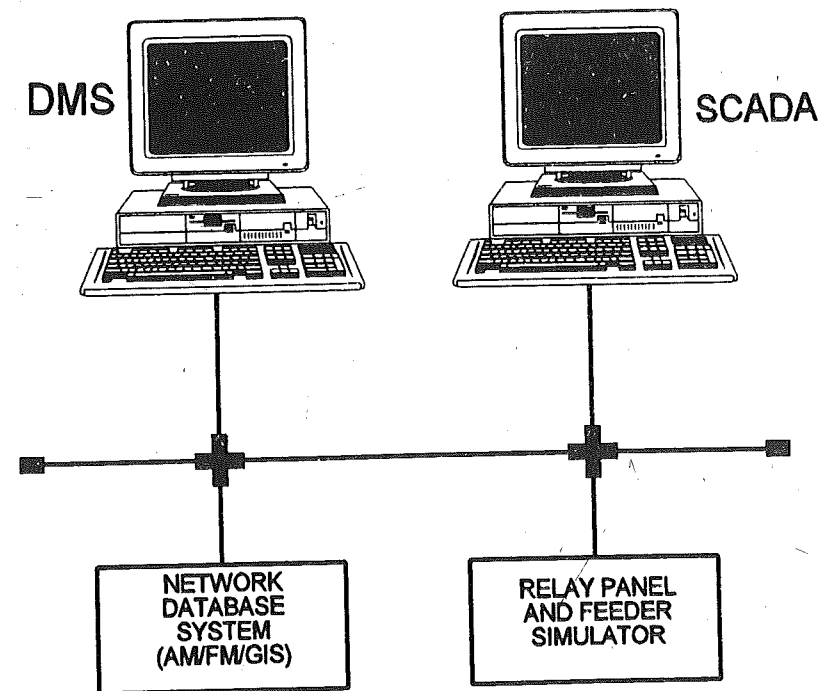

Fig. 6. The development platform

4.2 Computer System Integration

The DMS PC is connected to a local area network (LAN), which provides access to the other information systems (SCADA, AM/FM/GIS, etc.). The basic idea in integrating the independent DMS to other systems is to have well-defined data interfaces and partially separated programs to improve the flexibility of the system. The integration is illustrated in fig. 7.

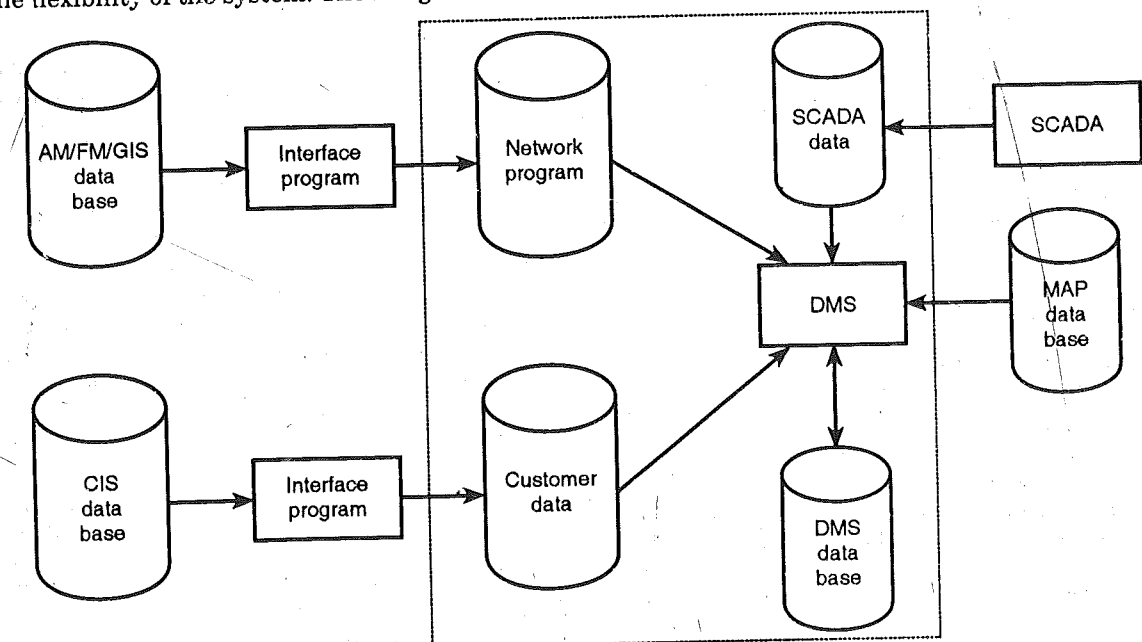

Fig. 7. Data interfaces of the DMS

4.2.1 The Network Data Interface. A separate program is used to generate the DMS's internal network model. The interface program has direct access to the network database, from which the data needed is read and processed. The changes in network data (new lines and reinforcements) are updated to the AM/FM/GIS database by its own applications. The interface program generates the DMS's object oriented network model and stores it in the database used by the actual DMS. Using this kind of interface a separate program module has to be developed for every network information system vendor, but the amount of coding is rather small compared with coding the whole system. The use of standard database management systems in the AM/FM/GIS simplifies the interface further with possibilities to use SQL queries. The daily or weekly updating of the DMS's database can be done as a background process without greatly disturbing the actual DMS.

The transferred data includes:

- line section data of substations and feeders
- codes of line section nodes
- coordinates of line sections
- type of line section
- line section length
- line data (resistance, reactance, etc.)
- distribution transformer data
- primary transformer data
- switching device data

4.2.2 The SCADA Interface. The basic idea in the SCADA connection is that there are resources shared by the SCADA and DMS. The SCADA system maintains both the cyclic and event based data so that the DMS can follow them. Because the volume of data is considerably low and the connection is one-way, it is quite easy to implement.

The transferred data includes:

- a list of open switches
- feeders, load current and busbar voltage measurements
- event data and measured fault currents
- weather data

The SCADA updates the lists of open switches following any change in switching states. The measurement and weather data is updated time channel-based once an hour. The event data is generated following certain events (e.g., a fault).

In the current DMS the SCADA interface uses intermediary files, which are updated by the SCADA system. The DMS monitors the contents of the intermediary files as a background process. The detection of a change initiates the process needed in the DMS. In one-way integration the file-based connection has proven to be rather serviceable and easy to develop. At present a new connection based on TCP/IP messages is under development to provide a two-way interface.

4.2.3 The Customer Information System Interface. The updating cycle of the customer information system interface is rather long compared with the previous ones, maybe some months. The interface is realized using intermediary files, which are generated by an interface program. The transferred data includes the energy consumption of the customers, the distribution transformer to which they are connected and the customer group to which they belong.

In the pilot implementation the CIS interface is not needed at all in the DMS, because necessary data can also be obtained from the AM/FM/GIS system.

4.2.4 Telephone Answering Machine Interface. Merlin Systems Ltd. is a vendor of a DOS-based telephone answering machine which is composed of a PC provided with a soundcard and application software. The answering machine can be connected to the direct numbers or subnumbers of a telephone exchange. It can answer several calls simultaneously. The answering machine is also connected to the LAN, and a real-time connection to the DMS has been built.

The interface between the DMS and the answering machine is a file in the shared disk. The DMS creates and updates the file which contains the coded information relating to the prevailing fault situation. The file includes several lines which each describe an individual fault. When a customer

calls, the answering machine reads the content of the file and forms the answering message based on the coded information. The answering message includes various submessages (e.g. names of primary substations and feeders, clauses relating to the progress of restoration, and sentences greeting a customer), which the operator records in advance. The answering machine forms the answering message by combining recorded submessages.

The DMS integration permits the use of the sophisticated network model and the user interface of the DMS, and automatic operation in real-time even in an unmanned control center. As a further development the answering machine will be provided with an advanced speech synthesizer which can mimic language from an ASCII text. The DMS writes the changeable parts of the answering message (e.g. the names of de-energized distribution substations) as an ASCII text in a file, and the answering machine reads them as such. This will emphasize the importance of the DMS integration.

4.2.5 The Background Map Interface. The background maps on a scale of 1:200000 are shown in wide overviews. A more accurate background map (i.e. 1:20000) is automatically used when the zooming area is small enough (e.g. 6 km wide).

The background maps are founded on commercial digital geographical maps. These include a large volume of data, which is problematic in viewing large regions. The size of a commercial file including the geographic data of 6400 km² on a scale of 1:200000 is about 16 Mb as a Windows bitmap. The data of 100 km² on a scale of 1:20000 represents 3 Mb. When operating with MV-networks, the average view of the screen is from 50 km² to some thousands of square kilometers. Thus commercial geographic data cannot be used as such in the efficient operation of the DMS. The background maps are prepared beforehand to suit the needs of effective use, and are stored in the geographical database maintained by the DMS. The data is modified so that the screen is always updated in a few seconds. The time includes the network drawing, too.

4.2.6 GPS. The Global Position System (GPS) can be used in locating the working crew. The GPS-device gives the spherical coordinates, which can be transferred to a notebook, or to a mobile telephone and, via a modem, to the control center. The DMS reads the coordinates, converts them as rectangular, and shows the location of the working crew on the background map. The moving target can be shown by the mouse on the background map. The DMS represents the target as spherical coordinates, which can be transferred further to the GPS-device.

4.3 THE DMS DATABASE

In addition to the external data sources the DMS has its own database to provide storage for DMS specific data. The main data consists of the status information on manual devices, load forecasts and the parameter data on the system. In the current implementation the geographical database is also included in the DMS database providing the road network data and the terrain conditions (forest, field, etc.) of each line section. An alternative way is to rely on commercial digital geographical data sources.