

(a) Fourbar linkage

(b) Fourbar linkage

(c) Radial compressor

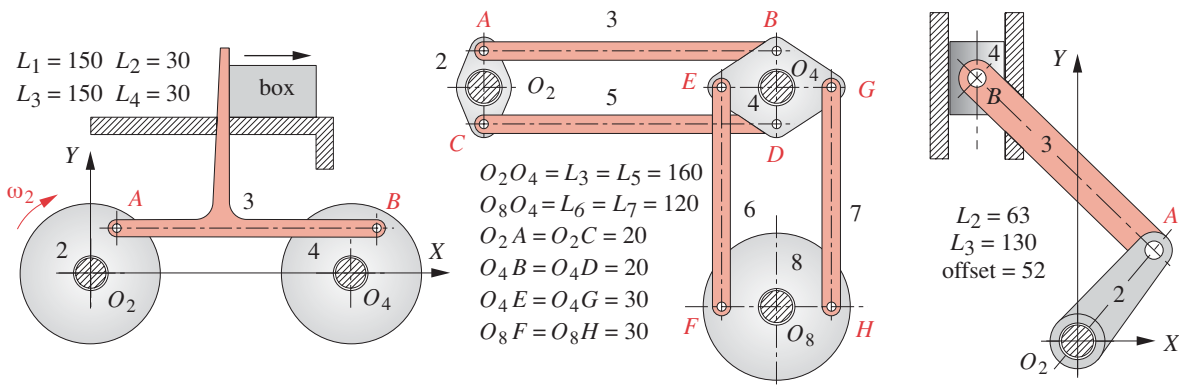

(d) Walking beam conveyor

(e) Bellcrank mechanism

(f) Offset slider crank

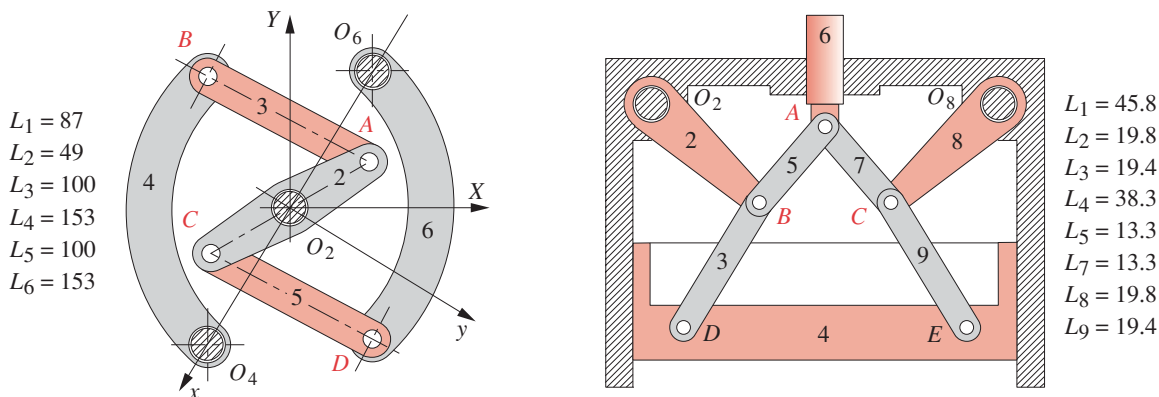

(g) Drum brake mechanism

(h) Symmetrical mechanism

all dimensions in mm

FIGURE P4-5

Mechanisms for Problem 4-18 Adapted from P. H. Hill and W. P. Rule. (1960) Mechanisms: Analysis and Design, with permission

See the text for the problem statement.