

(a) Sixbar linkage

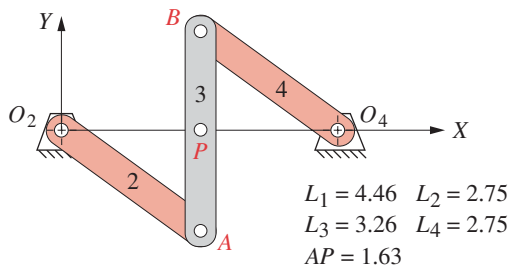

(b) Fourbar linkage

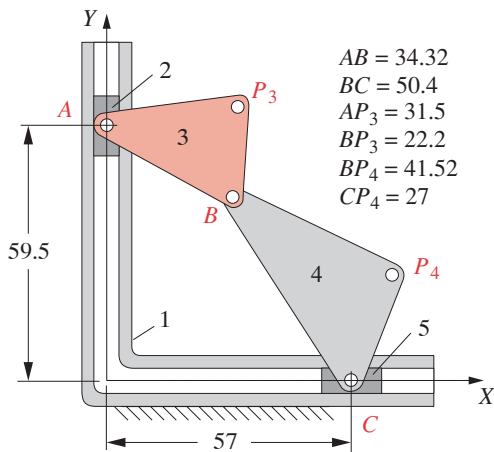

(c) Dual crosshead mechanism

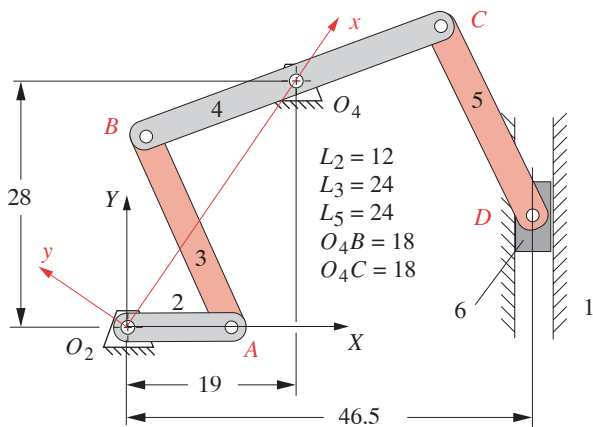

(d) Sixbar linkage

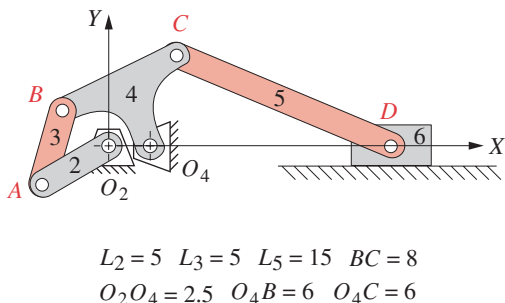

(e) Draglink slider crank

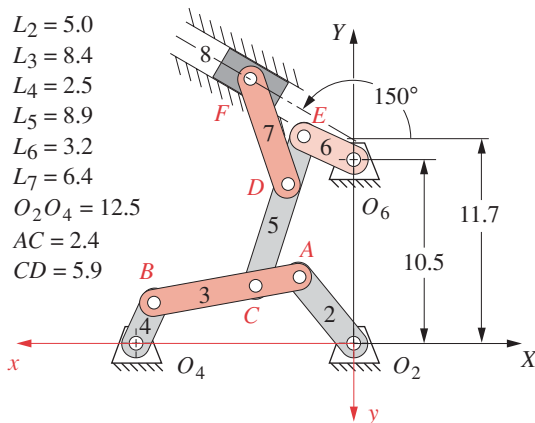

(f) Eightbar mechanism

FIGURE P6-33

Problems 6-91 to 6-103

see text for problem statements