

(a) Sixbar linkage

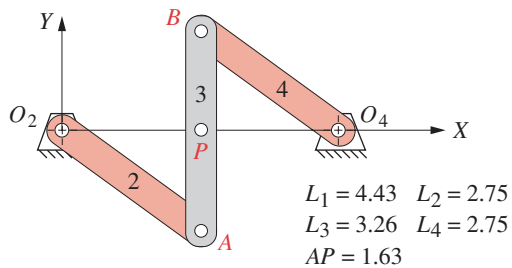

(b) Fourbar linkage

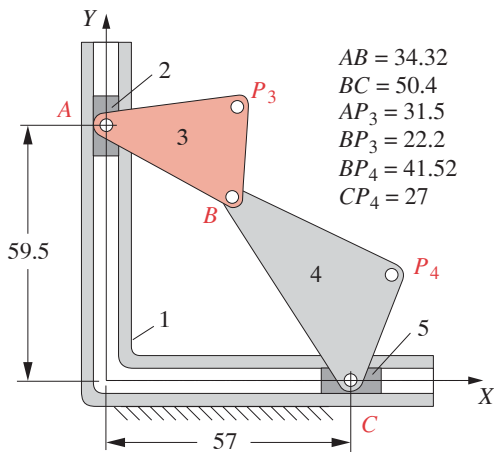

(c) Dual crosshead mechanism

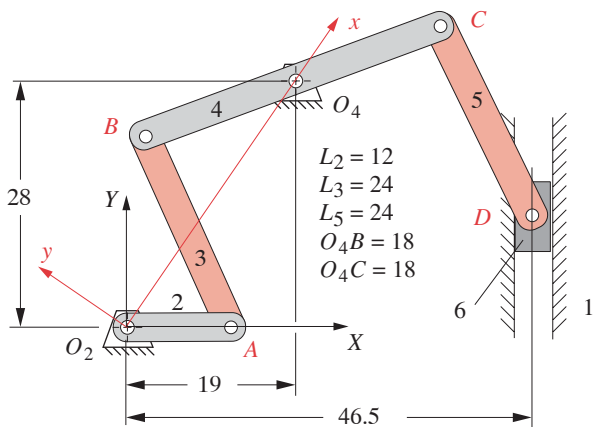

(d) Sixbar linkage

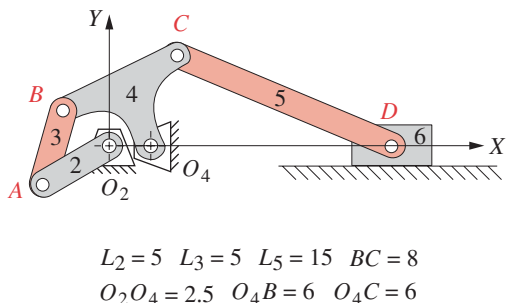

(e) Drag link slider-crank

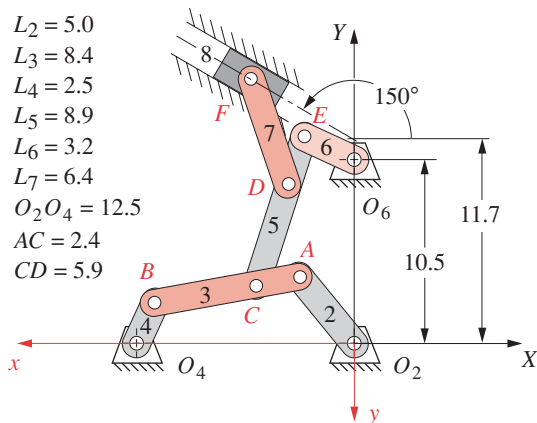

(f) Eightbar mechanism

FIGURE P7-30

Problems 7-75 to 7-86

See the textbook for problem statements.