



## UltraLogic™ 384-Macrocell CPLD

### Features

- 384 macrocells in 24 logic blocks
- In-System Reprogrammable (ISR™)
- Fully PCI compliant
- Full JTAG compatibility
- 3.3V or 5V operation
- Programmable speed/power options
- 192 I/O pins
- 4 dedicated inputs/clocks
- No hidden delays
- High speed
  - $f_{MAX} = 100 \text{ MHz}$
  - $t_{PD} = 12 \text{ ns}$
  - $t_S = 6 \text{ ns}$
  - $t_{CO} = 6.5 \text{ ns}$
- Available in 240-pin PQFP package
- Pin compatible with the Ultra39448

### Functional Description

The Ultra39384 is a high-density, high-performance Complex Programmable Logic Device (CPLD) providing in-system reprogrammability (ISR) and full Joint Test Action Group (JTAG IEEE1149.1) compatibility. It is part of the Ultra39000™ family of fast, reconfigurable CPLDs, which have been designed to bring the high performance and the ease of use of 22V10s to ultra high-density PLDs. The entire family is also fully compliant with the PCI Local Bus Specification and will operate at either 3.3V or 5V.

The 384 macrocells in the Ultra39384 are divided between 24 logic blocks. Each logic block contains 16 macrocells along with a product term array and a fast, intelligent product term matrix. Each logic block in the Ultra39000 architecture is connected through a Programmable Interconnect

that produces extremely fast and predictable paths through the device.

All members of the Ultra39000 family feature an abundant number of I/O resources. The Ultra39384 contains 192 I/O pins as well as four dedicated inputs/clocks and provides both fast synchronous and asynchronous clocking capabilities.

Additionally, the Ultra39384 features a programmable speed/power option that allows users to optimize designs for either ultra-fast performance or ultra-low power. The family also provides slew rate control for each of the outputs, which reduces switching noise. And finally, the Ultra39384 features a very simple timing model that results in parameters that are not dependent on the device resources utilized or the type of application being implemented.

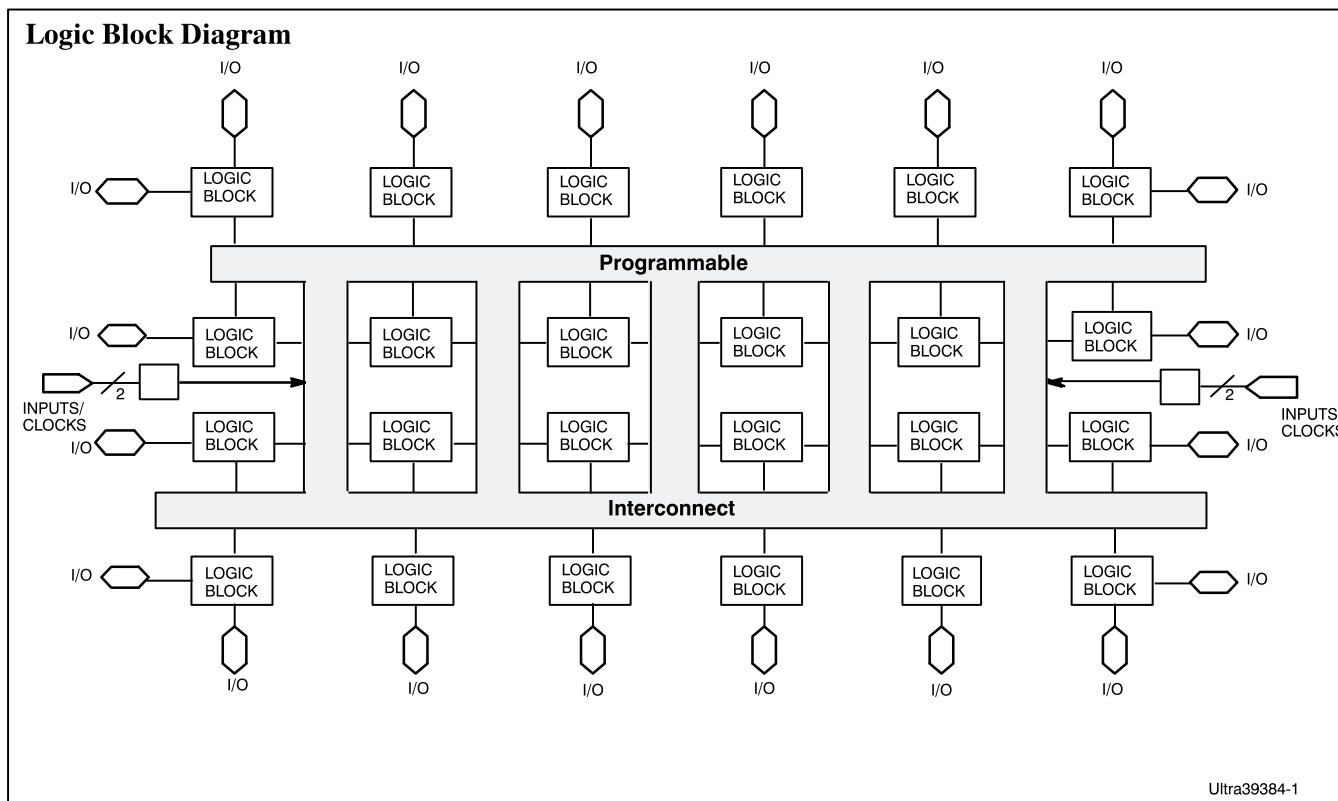

UltraLogic, ISR, and Ultra39000 are trademarks of Cypress Semiconductor Corporation

Document #: 38-00472