

GPS BASED COLLEGE BUS TRACKING SYSTEM WITH SMS ALERT

SURESH DESHMUKH COLLEGE OF ENGG. SELUKATE, WARDHA.(442001)

Priyanka V. Pawade
ppriyanka8541@gmail.com
Suresh Deshmukh college of Engg.

Shraddha S. Wagh
ms.shraddhawagh@rediffmail.com
Suresh Deshmukh college of Engg.

Chetana S. Sawalkar
chetana.sawalkar90@gmail.com
Suresh Deshmukh college of engg.

ABSTRACT:

Vehicle tracking systems commonly use Global Positioning System (GPS) technology for locating the vehicle, but other types of automatic vehicle location technology can also be used. Vehicle information can be viewed on electronic maps via the Internet or specialized software. This GPS will be location the position of vehicle and transmit that data to the microcontroller. If the vehicle is theft it automatically sends location of the vehicle to its owner as a SMS through GSM modem. The GPS is nothing but the global positioning system. It takes the data from the satellite. And measures the latitude and longitude position. After taking this position of each stop of college bus it fixed in the microcontroller 8051on

specific memory location. After that GPS continuously scan the latitude and longitude position ones the position is match with the stored memory location in microcontroller 8051 which is fixed previously. And that after matching position then the message is displays on LED display. After that the person who is outside the bus if he call the mobile number of the GSM then he get the exact location of the bus by sending the sms by that GSM module to particular person.

Keywords: Global Positioning System (GPS), Global System for mobile communication ,Microcontroller LED Display.

Introduction

The main goal of this project is to design college bus location system, which will track the location of the bus using GPS. Due to security concerns, we will be using GPS system to monitor college buses to find approximate location of the bus and GPS location Of The bus status will be displayed at all the bus terminals using an LCD display

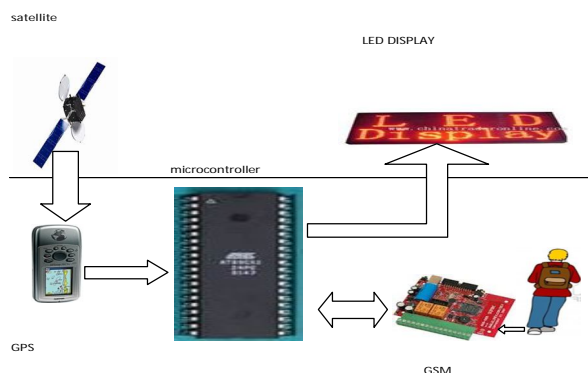

Hardware framework for tracking system is shown. System contains high Performance ARM controller, a GPS, and GSM modem and overall system reside into a college bus. A tracking system will provide effective real time college bus location reporting. Tracking system will inform where your college bus is and where it has been, how longer it has been there. The basic function of in vehicle unite is to acquire, Monitor and transmit the position latitude, longitude, time to management center either at fixed interval or on demand. Microcontroller unit form the heart of tracking unit, which acquires and process the position data from the GPS module. The GPS receiver of vehicle terminal receives and resolves the navigation message broadcasted by GPS position satellites, computes the longitude and latitude of vehicle coordinates, transforms it into the GSM message form by GSM Communication controller, and sends the message to monitoring center via the GSM network. During vehicle motion, its real-time parameters such as location are reported by SMS message. The system takes advantage of wireless technology in providing powerful management transportation engine. The use of GSM and GPS technologies allows the system to track college bus and provides the most up-to-date information about ongoing trips. This system finds its application in real time traffic surveillance. It could be used as a valuable tool for real time student information, congestion monitoring, and system evaluation. An

intelligent, automated vehicle tracking system can resolve following problems such as, late arrivals to scheduled, improper use of company time and resources, unsafe driving habits, assigned routes, inefficient dispatching, and passenger's dissatisfaction. This can lead to better traffic flow modeling and a better understanding of driver behavior. This project includes various features like ingenuity, simplicity of design and easy implementation. It is completely integrated so that once it is implemented in all college bus, then it is easy to track college bus any time.

The GPS is nothing but the global positioning system. It takes the data from the satellite. And measures the latitude and longitude position. After taking this position of each stop of college bus it fixed in the microcontroller 8051 on specific memory location. After that GPS continuously scan the latitude and longitude position ones the position is match with the stored memory location in microcontroller 8051 which is fixed previously. . And after matching that position then the message is displays on LED

display. After that the person who is outside the bus if he call the mobile number of the GSM then he get the exact location of the bus by sending the sms by that GSM module to particular person.

Interfacing of 8051 with GPS

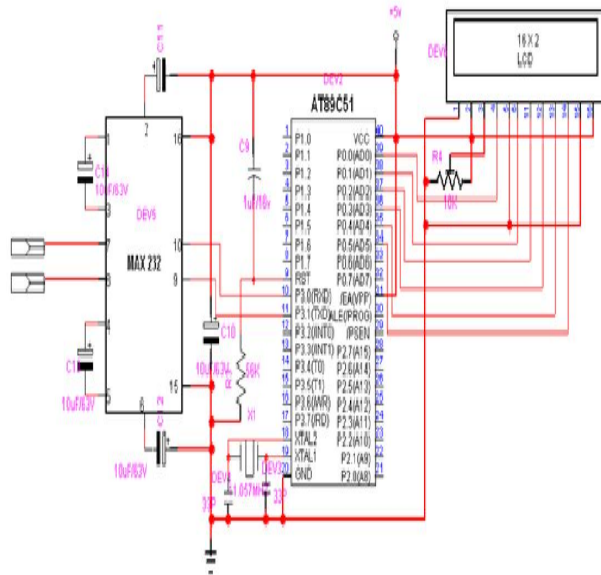

Conclusions:

This project is useful for college or school bus due to the continuously alerting position by using sms. In which gps and gsm module is use for detection purpose. And hence it is useful for students as well as parents and responsible respective authority for safety purpose.

References:-

[1] Larry L. Peterson and Bruce S. Davie. Computer Networks: A systems approach. Morgan Kaufmann Publishers,2009

[2] Lawrence Harte , Bruce Bromley and Mike Davis. Introduction to GSM ,2nd edition. Althos Publication , 2009.195

[3] "Cellular History". etsi.org. European Telecommunications Standards Institute. 2011. Archived from the original on 5 May 2011. <http://www.webcitation.org/5yRQXw2sv>. ensign a pan-European mobile technology."

[4]Retrieved 5 May 2011. "The task was entrusted to a committee known as Group Spécial Mobile (GSMTM), aided by a 'pe Leader (7 September 2007). "Happy 20th Birthday, GSM". zdnnet.co.uk. CBS Interactive. Archived from the original on 5 May2011.

<http://www.webcitation.org/5yRRJnMZw>.

Retrieved 5 May 2011. "Before GSM, Europe had a disastrous mishmash of national analogue standards in phones and TV, designed to protect abroad."