

Switch location and parameter detection using advanced multimeter

¹Akanksha Vaidya ²Gauri Patil

³Nikita Kshirsagar ⁴Payal Shambharkar

Electrical Department, G. H. Rasoni Institute of Engineering & Technology for Women,
Nagpur- 440028, India

Abstract- This paper is all about designing & making a device which is in the form of an Advanced Multimeter. This device will help to tackle with problems. Whenever there is any fault in any part of system, this device can be use as a detector by swapping or holding across the faulty equipment which has a problem and immediately a LED light will glow near the switch which will help to detect the switches belonging to faulty equipment, and then that equipment can be switched off without affecting the others parts and the system. This saves the Efforts &time. Also an additional facility is provided which will help to detect the current state of the machine (i.e. its speed, current, voltage, temperature).

Keywords- Multimeter, switching and sensing parameters.

I. INTRODUCTION

The electrical industries consist of many types of electrical equipment, which are installed for different applications. Whenever there would be any fault in any machine or a part of system, complete system is being turned off by isolating the power supply. In this procedure, the equipmentø which are working without fault also stops.

In such situations the operation of all fault detecting activities are very critical to

understand in a day or in couple of days. When any new comer joins the industry, it would be very difficult for him to understand the system. If this new comer needs to turn off the power supply, he has to go through a number of switches and panels. The reason is that this new joiner is not aware of the actual switches of each and every machine. And for that he has to go through manuals and cross checking with so many switches which results delay of time& human error.

This paper is all about dealing with the above problem. We are designing & making a device which is in the form of an Advanced Multimeter with additional feature of switch location in the panel. Normally Digital multimeter is one of the most common measuring equipment in the automatic measuring system and is capable of fulfilling measurement of ordinary signal. With the development of embedded system and widening application of virtual instrument in the measuring field, the measurement technology has experienced great development and features standardization, intelligentization and modularization. Currently the volume of multimeter becomes smaller while the precision is higher. We are providing an additional facility in the digital multimeter for switch location in the control panel. This Device will also help to detect some parameters (such as Voltage, Current, Temperature, and Speed). Whenever there is any fault in any part of system, our device can be used as a detector by swapping the

multi-meter across equipment which has a problem and immediately a LED light will glow near the switch which will help to detect the switches belonging to faulty equipment and then that equipment can be switched off without affecting the others system also on the display which is interfaced at the back of the multimeter will show the connecting path of the equipment.

II. PREVIOUS WORK

In past few years, Multimeter has become an area of interest and lot of work had been done on it. The most advanced multimeter was produced by XuMeng, Li Zhi called “*Design and Realization of Digital Multimeter Module Interface Circuit Based on LXIbus*”[1] in the year 2012. In this paper digital multimeter module(DMM) interface circuit design scheme based on LXI bus is proposed. LXI instrument bus is regarded as a new generation instrument bus, it contains computer network technology. Compared with conventional bus systems in building distributed weapon system, it has an

Unparalleled advantage, for it solved problems in the test distance limitations of traditional bus. DMM is the most commonly used measurement module in automatic test system, the measurement accuracy and measurement capabilities continue to improve, based on these, this paper designed the DMM based on LXI bus, mainly on the interface circuit design. It uses S3C2440 as the interface circuit using the main processor, and designed external circuit such as the power supply circuit, crystal oscillator circuit; memory circuit and network interface circuit, and achieves interface functions of DMM based on LXI bus.

Huang Jing, Qiao Leline, “*Research of Automatic DigitalMultimeter Interface Technology based on UART*”[2]in the year 2012 In this paper the method of serial

communication using UART is used in Digital multimeter as multimeter is huge and not compatible automatic digital multimeter provide a serial communication interface to avoid the trouble of moving the instrument hence in this paper the serial communication method using UART is used which helps the user to quickly measure voltage, current online etc which is convenient and easy.

Wang Lei-gao, “*Design of Digital Multimeter ModuleBased on ARM*” [3]in the year 2010 in this paper design and implementation of digital multimeter module based on ARM is given. The paper describes about the LTC2440 which was employed to conduct high-precision AID conversion, and S3C2440 which was utilized as the master chip to control analog switch group to carry out function setting and range switching, and perform data processing and real-time measurement result displaying as well. It was proved that, the digital multimeter module with reliable performance and easy operation, possesses relatively high measurement precision, and can satisfy the measurement requirement of laboratory. The digital multimeter module following the concept of modularization and intelligentization takes direct voltage adjusting circuitry as the base and employs high-precision AID conversion chip to accomplish the design. The experiment has shown that the multimeter module, the precision of which can reach 5Yz, works steadily and achieves the anticipated design objective.

Xiaoxiang Chen, “*Development of Intelligent MultimeterSystem Based on Lab VIEW*” [4] in the year 2012. In this paper an intelligent multimeter system using 51 series microcontroller C8051F020 as the controlling core is used and the interface module is based on LABVIEW. The system consists of measuring module, storage module, communicating module, gear selecting module, microcontroller module. This paper focuses on the design and

realization of intelligent multimeter system. Microcontroller module reads corresponding information from storage module and then generates control signals when one gear is selected by gear selecting module. Receiving the control Signals, measuring module measures the signal under test and return the result. An effective value is converted from the result by microcontroller, and sends to PC to display in the interface.

Jeff Robins, " Incorporating Advanced InstrumentationCapabilities into a PXI Digital Multimeter Instrument". [5] in the year 2012. This paper discusses the requirements and techniques used to develop a PXI-based, high performance DMM. A review of the required performance parameters is presented along with an analysis of the alternative design methods employed in order to achieve the necessary performance capabilities without compromising the overall capabilities of the hardware. Areas covered in this paper include. A discussion of design techniques which includes the use of multi-functioncircuitry to reduce overall volume requirements, the conversion of purely analog circuitry into a mixed signal format to reduce volume and power requirements, minimizing power supply noise when replacing a mains based power supply with isolated and non-isolated DC/DC circuitry and the requirement to operate over an extended temperature range.

Charudatta Meshram and R.W.Jasutkar, "Design of digital multimeter for locating switch in panel"[10] in the 2014. This paper discusses the correct switch just by swapping or inserting the copper clad card in the device. This paper helps in locating a switch in the panel. Thus, the bond symbols are removed from the switches and avoid the confusion of wires which have many bunches.

III. WORKING

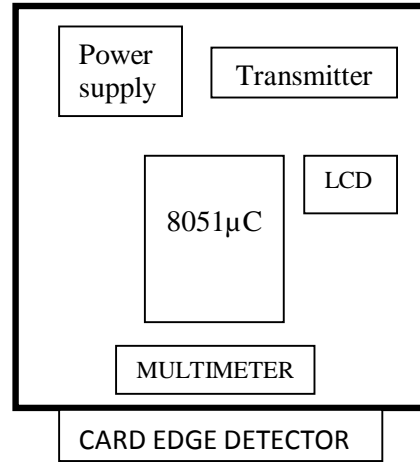

We are designing an advanced multimeter which performs all the operations of a multimeter as well as an additional facility is provided for switch detection and parameter sensing. This will be done by a bar code or card reader. The card reader is attached with the multimeter. Whenever the multimeter is inserted or swapped across the equipment the card will sense the device, the microcontroller will recollect the stored information immediately the display will give the exact location of the switch with data history. Along with it, the running parameter will also be compared with the rated parameter of the machine. The card reader with help the microcontroller to recollect the data stored in it. The Led will glow on the control panel for this particular switch. The exact path to the switch can be generated easily by this. If operator observers that the equipment needs immediate shut down or turn off then, he needs to just press the external button on the multimeter. This button is connected to the transmitter attached inside the multimeter. The transmitters will transmit the signal. The receiver connected to the other in series with the switch will receive the signal and immediately the relay will cut off the supply, thereby protecting the equipment from damage.

IV. ADVANTAGES

1. The device is simple in construction and can be installed in every type of machine.
2. Power consumption is less
3. Automatic operation.
4. Multimeter is easiest to carry
5. This multimeter automatically indicates switch of a particular equipment through led in the panel.
6. Quick detection of over exciting and limiting parameters such as (speed, temperature, voltage, current).
7. The output will be stored in computer as data base.

V. RESULT AND DISCUSSION

This device is giving good and accurate results. As soon as the multimeter is inserted in the copper clad card which is placed near the device or any appliance the concern switch led of that device in the control panel glows. The concern parameters of the particular device also displays simultaneously on the LCD. The multimeter is attached with a transmitter which when transmits a signal at a particular frequency. The receiver is placed in the control panel receive this particular frequency and decodes it. The relay will open and the circuit is disconnected from the main supply.

VI. CONCLUSION

This device is not dependent on fault condition but it is essential even whenever small faults are developing in equipment and we want to find out its switch in the control panel and the sensing parameters (Current, Voltage, Speed, and Temperature). The skill person will easily identify these small developing faults. So to come over these problem for finding its concerned switch the person will simply insert our designed multi-meter across any the copper clad card equipment and instruct the person at the supply system about the switch which will

be easy to locate even when the bond symbols are removed from the switches or the wire have many bunches of wires. The sensing parameters will also help in increasing the device life. The parameter will help us to decide the load and time of operation for better efficiency.

VII. REFERENCES

- [1] Wang Lei-gao. Design of Digital Multimeter Module Based on ARM.(CMCE) 2010.
- [2] XuMeng, Li Zhi. LXI High-precision Digital Multimeter Module, Mechanical Engineering & Automation.2009,12.
- [3] Huang Jing,QiaoLeling. Research of Automatic Digital Multimeter Interface Technology based on UART.2012.
- [4] Zhanyou Sha, The principle and application of new digital multimeter [M]. Beijing: China Machine Press, 2006, pp7-14.
- [5] Agilent Technologies. Agilent 34401A Multimeter Service Guide.2000.
- [6] R.A. Witte, "Electronic Test Instruments: Analog and Digital Measurements", Prentice Hall.
- [7] W. Claes, W. Sansen, R. Puers, "Design of Wireless Autonomous Datalogger IC's, The International Series in Engineering and Computer Science, Vol. 854, Springer
- [8] National Instruments. (2010, May 28). Digital Multimeter Measurement Fundamentals [Online] Available <http://www.ni.com/white-paper/3295/en>
- [9] Fluke. (2011, January). Understanding specifications for precision multimeters (Rev 02.) [Online]. Available: http://support.fluke.com/find_It.asp?Document=254779