

PHARMACEUTICAL INDUSTRIAL AUTOMATION USING PLC

PRANAV D. DHOMNE, AKASH M. BALKI, PIYUSH B. GIRHEPUJE
SUDESHNA S. MENDHULE, KAJAL PADHIHARI, SHREYAS S. BOKADE

Final Year B.E.

Department of Electrical Engineering, Yeshwantrao Chavan College of Engineering, Nagpur, (MH) 441110 India.
E-mail: pranavdhome10@gmail.com, akashbalki09@gmail.com, piyushgirhepuje94@gmail.com

Abstract- The various sensors essential for smart monitoring and control of various electric appliances in real time using programmable logic controller (PLC) has been accomplished in the present work. The real time system developed is highly Effective, efficient and robust. The concept of home automation is to connect all the systems and devices to a central controller so that they can be controlled from anywhere and react to one another.

Keywords- Automation, Ladder programming, Programmable logic controller, Sensors.

I. INTRODUCTION

The work is based on an Automation System where interface is by a Programmable Logic Controller. Implementing a PLC application which can handle various appliances of a home like Lights, Smoke sensor, Water level detector and various other appliances.

Now everything is going to be automated using modern control techniques and vogue technology. The appliances can be connected with network grid and accessed using a Smartphone. This idea shall lead to the development of smart communities.

The work illustrates how PLC's can be used for control and monitoring of lights, sensors, and other electronic appliances at homes, offices etc. Automation and real time monitoring of inputs is easily accomplished. The idea of computerized control and its application saves precious time and manual effort, which can be utilized for better purposes. Home automation provides a more convenient & elegant atmosphere for the family to compliment and match the lifestyle.

II. PROGRAMMABLE LOGIC CONTROLLER (PLC)

The main attributes of programmable logic controller and sensors are presented in this section. A PLC is a digital computer used for automation of electromechanical processes, such as control of machinery on factory assembly lines, amusement

Main Features

Control panel with PLC (grey elements in the centre figure 1). The main difference from other computers is that PLCs are armoured for severe conditions and have the facility for extensive input/output arrangements. These connect the PLC to sensors and actuators. On the actuator side, PLCs operate electric motors, pneumatic or hydraulic cylinders, magnetic relays, solenoids or analogue outputs.

As PLCs have become more advanced, methods were developed to change the sequence of ladder execution, and subroutines are implemented. This simplified programming could be used to save scan time for high-speed processes.

System scale

A small PLC will have a fixed number of connections built in for inputs and outputs. The processor and selection of I/O modules are customized for the particular application. Several racks can be administered by a single processor, and may have thousands of inputs and outputs.

rides, or light fixtures. Unlike general-purpose computers, the PLC is designed for multiple inputs and output arrangements, extended temperature ranges, immunity to electrical noise, and resistance to vibration and impact [1-6].

A PLC is an example of a hard real time system since

output results must be produced in response to input conditions within a limited time, otherwise unintended operation will result.

User Interface PLCs may need to interact with people for the purpose of configuration, alarm reporting or everyday control. A human-machine interface (HMI) is employed for this purpose.

A simple system may use buttons and lights to interact with the user. Text displays are available as well as graphical touch screens.

Communication

PLCs have built in communication ports, usually 9-pin RS-232, but optionally EIA-485 or Ethernet. Most modern PLCs can communicate over a network to some other system, such as a computer running a Supervisory Control and Data Acquisition (SCADA) system or web browser.

Ease of Programming

PLC programs are typically written in a special application on a personal computer afterwards it is downloaded on the PLC via direct-connection cable.

Comparison

PLCs are well adapted to a range of automation tasks. PLC applications are typically highly customized systems, so the cost of a packaged PLC is low compared to the cost of a specific custom-built controller design.

In recent years "Safety" PLCs have started to become popular, either as standalone models or as functionality and safety-rated hardware added to existing controller architectures. These differ from conventional PLC types as being suitable for use in safety-critical applications for which PLCs have traditionally been supplemented with hard-wired safety relays.

MicroLogix 1200 by Allen-Bradley.

The following are the main features [3-4].

- i). The MicroLogix 1200 is a 24 point Controller with 15 inputs and 10 outputs
- ii). It contains an isolated RS-232/ RS-485 combo port for serial and networked communication
- iii). Four latching or pulse-catch inputs and four interrupt inputs
- iv). Controller has in-built independent 20 kHz high-speed counter
- v). Offers Programmable Limit Switch function
- vi). Provides program data security
- vii). Expands up to 136 I/O points
- viii). Compatible with 1762 MicroLogix Expansion I/O modules.

Water Level Detector

level of water in the tank will be monitored. If the level drops below or rises above the certain prescribed limit automatic alarm should be generated to notify authorities.

Smoke Detector for Fire

Smoke detector on exposure to smoke generates alarms which notify the fire department which can take appropriate action and thereby helps to avoid hazards caused by fire. Ravel 316 series smoke sensor is used for the present scenario. It operates at 10-30V DC supply.

Proximity/ Mechanical Detector for burglary

Sensor is deployed to secure any highly valuable item. When circuit completes or the object is displaced from its vicinity a silent alarm generated will notifying the inmates.

Figure 1. MicroLogix 1200 By Allen-Bradley which is a 24 point controller

SENSORS USED

Various sensors are used for implementing the present controllable system. These are as mentioned below and explained in nutshell:

This shall lead to improved streetlight system. Below a certain level of sunlight the lights will be automatically or manually turned on. The cell resistance falls with increasing light intensity. Applications include smoke detection, automatic lighting control and burglar alarm systems.

Earthquake Sensing Sensor*

This sensor shall detect the pre-occurrence of an earthquake and shall provide a window of 10-17 seconds. The monitoring program will generate the red-alert speaker alarm to notify the community about the upcoming natural calamity/ disaster. This sensor provides an early warning by detecting the sound wave of the earthquake before its shear wave strikes the area . *This sensor shall be used in the future work of the work.

SYSTEM DEVELOPED III.1

In the present work a smart monitoring and fully automated system has been developed. Schematic described in Figure 4, shows the interconnection of various sensors and appliances used with

Figure 2. Digital Smoke Sensor alongside with Proximity Sensor (right)

2



Programmable Logic Controller community superior security and welfare.

Sensing smoke, earthquake, water level in tank, intensity of light to control street lights incorporate some of the major aspects of the developed system.

rules are typically executed sequentially by software, in a continuous loop (scan). By executing the loop fast enough, typically many times per second, the effect of simultaneous and immediate execution is achieved, if considering intervals greater than the "scan time" required executing all the rungs of the program.

A typical ladder program written in RSLogix 500 is shown in Figure 5. The green line represents Ladder and the blue line is called a Rung. If any switch is pushed ON then it also turns green. By visualizing the change of state of switches in software real time response of the system is monitored online. Any switch can be forced or actuated through the software irrespective of the actual system input.

Figure 3. Block diagram of smart monitoring and control of electric appliances

Working of the System

- i). Each sensor is linked to a central control unit through a programmable logic controller (PLC).
- ii). Real time status of each sensor is monitored.
- iii). In case of any miss-happening, the required precautionary and safety tasks are performed.
- iv). The central control unit is operated by either one or two officials.
- v). Immediate action can be initiated to avoid any accidents.
- vi). The concerned authorities can also be informed automatically.
- vii). System can take preliminary actions on its own for immediate preventative action.

METHODOLOGY OPTED AND TECHNIQUES USED

The methodology adopted and techniques are presented in this section.

Ladder Programming

Ladder logic is widely used to program PLCs, where sequential control of a process or manufacturing operation is required. As PLCs became more sophisticated it has also been used in very complex automation systems. Development and maintenance is simplified because of the resemblance to familiar relay hardware systems.

Manufacturers of PLCs generally provide associated

ladder logic programming systems. Ladder logic can be thought of as a rule-based language rather than a procedural language. A "rung" in the ladder represents a rule. When implemented with relays and other electromechanical devices, the various rules "execute" simultaneously and immediately. When implemented in a programmable logic controller, the

Figure 4. Ladder programming structure depicting various push down switches timer block and different types of outputs.

RESULTS AND DISCUSSION

The various results obtained in the present work are presented here. Their implications are also highlighted.

Software used and Coding

To run 32 bit programs developed in Rockwell Automation Windows XP have been used which is run on a virtual machine using VMware. VMware generates a Windows XP platform on existing operating system, so XP can be run as an application.

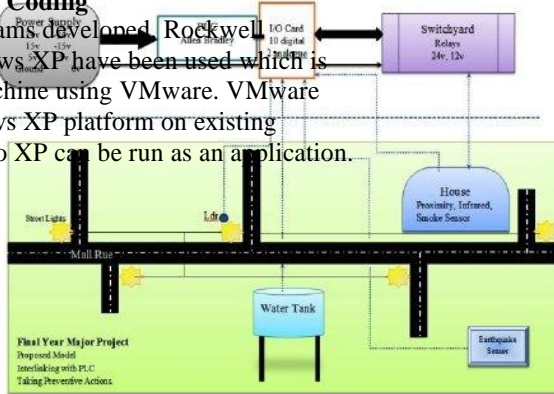

For making schematic and ladder programming of MicroLogix 1200 we have used RSLogix 500. RSLogix is developed by Rockwell Automation which is compatible with Allen Bradley PLCs. Various types of addressing formats used in RSLogix 500 are discussed in Table 1. Symbols used in programming are shown in Table 2.

Using PLC various sensors are connected in the developed system. Table 3 indicates the number of sensors used and their addresses. Each sensor acts as a switch and respective outputs are achieved if their logic is high.

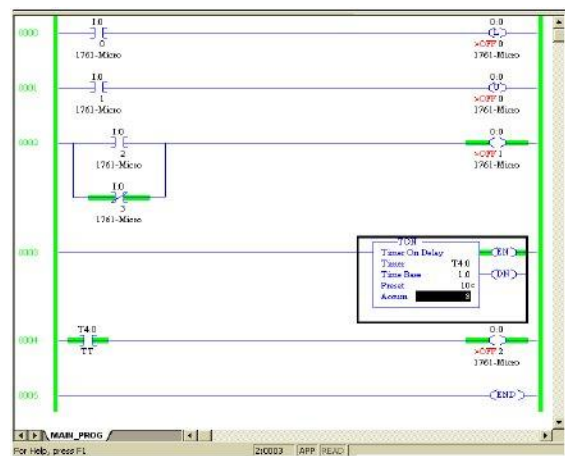

Table 3
Various Sensors Inputs and Outputs

| Type | Device | Address |
|----------|-----------------------------------|---------|
| Switch 1 | LDR Sensor | I:0/0 |
| Switch 2 | Smoke Detector | I:0/1 |
| Switch 3 | Infrared Sensor | I:0/2 |
| Switch 4 | Water Detection (Max.) | I:0/4 |
| Switch 6 | Water Level Detection (Min.) | I:0/3 |
| Switch 7 | Proximity Sensor | I:0/5 |
| Timer 1 | Activated at min. water detection | T4:0 |
| Timer 2 | Internal Timer | T4:1 |
| Output 1 | Street Light | O:0/0 |
| Output 2 | Indication about fire | O:0/1 |
| Output 3 | Motion Detection | O:0/4 |
| Output 4 | Water level (High) | O:0/2 |
| Output 5 | Water level (Low) | O:0/3 |
| Output 6 | Proximity Output | O:0/5 |

scenario of smart electric system developed. The small light bulbs represent the street lights and the bucket replicates a water tank. LDR and proximity sensors can be easily figured out in the photograph.

Figure 6. Complete scenario of smart electric system developed for controlling electrical appliances

The present work shows the significance of the programmable logic controller and its capabilities for developing smart electric systems.

CONCLUSIONS

The real time data acquisition monitoring and control system has been developed using Programmable Logic Controller and is highly effective, efficient and robust. A number of input-output modules are attached to a PLC proving its expandability and competence. The new expansion modules can be either digital or analogue and in the present work digital modules are used. The ease of programming and networking of sensors with PLC demonstrates the high user friendliness of the device. A single PLC can control whole industry as it easily replaces the old, obsolete and cumbersome relay logics. Hence the present work is of much importance to the electrical engineers and designers.

The developed system can be incorporated to a large society. It has been found that in case the numbers of inputs/ outputs in the PLC based system are increased along with the effective use of reliable sensors then the security and safety systems can be revolutionized. The present work can be linked over internet and an online SCADA monitoring system can be developed which shall provide the users real time status of the electrical appliances placed at any point around the globe.

REFERENCES

Gary Dunning, Introduction to PLC, 2001.

PLC verses other Controllers - Article, 31-1-2008.

<http://www.wikipedia.org>, "PLCs," 2013.

<http://www.thelearningpit/The Advantages of Using Programmable Controllers, How.htm>

Figure 5. Ladder program developed for interlinking various sensors with PLC

Figure 5 shows the Ladder program developed for interlinking various sensors with PLC. Figures 6 and 7 show the working conditions of PLC when various sensors activate the logic operation and the complete

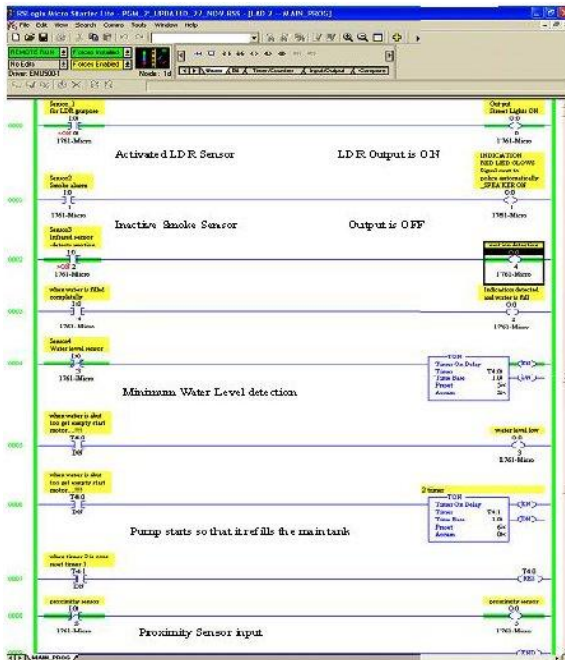
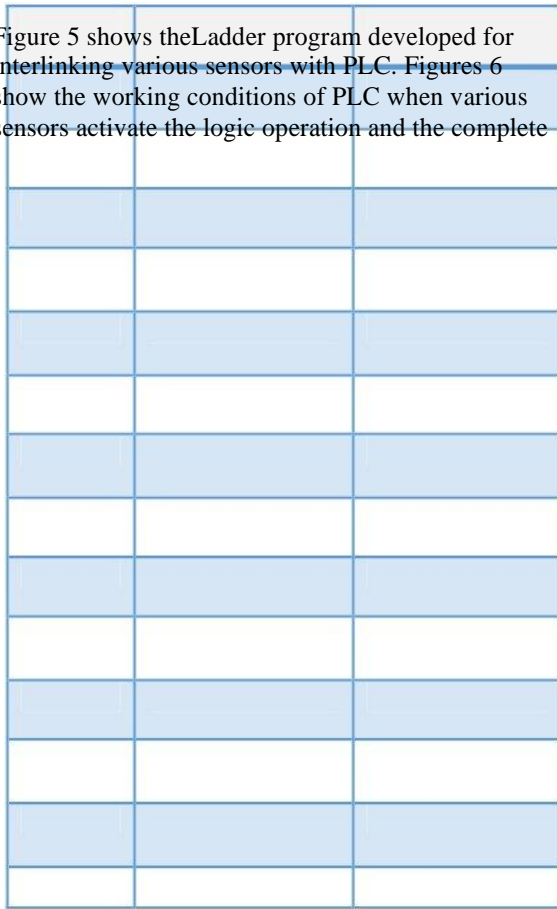

- [1]
- [2]
- [3]
- [4]

