

Smart Solar Water Irrigation system

Tejprakash R. Lilhare
Dept. of CivillEngg.
PJLCE, Nandenwan
Nagpur, India
lilhare.rahul@gmail.com

Reeta S. Damahe
Dept. of Electrical Engg.
DMIETR, Sawangi (meghe)
Wardha, India
Reetadamahe@gmail.com

Abstract— As we know in Mostly in 'India' Electrical Energy is generated by the burning of coal. This generation of electrical energy produces lot of pollution. And as we know solar energy is conventional source of energy, it is readily available 12hours in a day. Solar energy can became alternative to this non-conventional energy but there is problem is that photovoltaic cell are less efficient. In order to improve the efficiency of photovoltaic cells MPPT techniques are used.[1] In this paper we present that 12volt battery is charged with the help of solar panel & MPPT. Then this system is used for irrigation purpose by directly applying 12volt dc to the DC pumps with battery, it can also be used in fields by increasing solar panel & battery rating, DC pump for large scale use. It can also used in hotel & motels, banglos for gardening. This system is completely automated using IC 555.

Index Terms— MPPT, PV system, IC555, water tank, DC pumps, Sprinklers.

I. INTRODUCTION

In India farming mostly depends on monsoon, if it is delayed the farmer used irrigation but this is also not possible due to lot of energy crises in the rural area and urban area lot of pollution [2].As we know fossil energy sources are diminished day by day. To give pollution free, natural environment to our next generation it is need to use pollution free, noise free, inexhaustible source of energy like solar energy[3]. In order to obtain the solution for these problems solar energy used. It is readily available in minimum 10hours in day. But there is problem using solar energy that the energy from photovoltaic cells are less efficient due to the effect of irradiation, temperature, shadows, dust and many others.[4]

For improving the efficiency of energy from photovoltaic system different methods has been developed such as Constant Voltage (CV) / constant current (CC) method, Perturb and Observe (PAO) method and Incremental Conductance Technique (ICT) and they are valid in many applications. [5]

Nowadays, there are two main drawbacks in PV plants,the high cost of cells production and their low energy conversion efficiency. Commercial modules are assembled with efficiency between 6 and 16% depending on their technology.Due to this poor efficiency, strongly dependant on solar radiation level and operating temperature, it is very important to achieve its maximum value. There are two techniques to get best results. One is the use of electro-mechanical equipments. These equipments allow that PV modules keep the best position to obtain the maximum solar-radiation level during the sunny interval of the day. That is the raison they are known as sun Trackers.

And next one is the use of control techniques, applied to a switching converter, that force the module to operate in the optimal operating point, that it's the Maximum power point tracking (MPPT). Fig. 1 shows a basic MPPT system. [6]

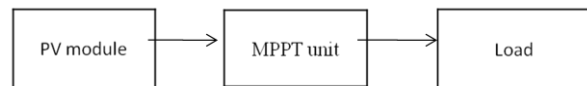

Fig. 1: Block diagram of a MPPT controlled photovoltaic system

The method used for tracking the maximum power point is constant current.This paper is divided into three parts. In part II, the main control techniques are presented. The constant current based battery charger is fully developed in part III. And in part IV, some simulation and experimental results are also included.

In this paper, with the help of MATLAB 2010 the PV panel to operate at maximum power a maximum power point tracker (MPPT) is modeled and connected to PV panel.

PV MODULE O/P CHARACTERISTICS

The PV model consists of a current source (I_{sc}), a diode (D) and a series resistance (R_s). The effect of parallel resistance (R_p), represents the leakage resistance of the cell is very small in a single module, thus the model does not include it. The current source represents the current generated by photons (I_{ph}), and its output is constant under constant temperature and constant incident radiation of light.The use of equivalent electric circuits (Fig. 2) makes it possible to model characteristics of a PV cell.

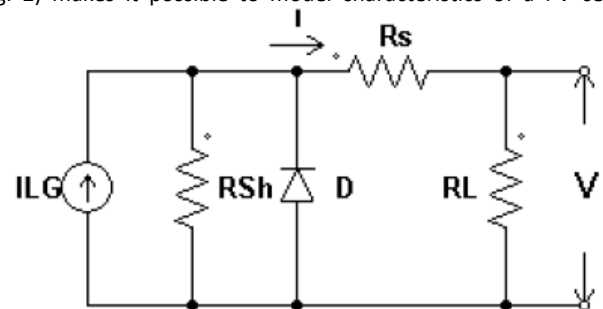

Fig. 2 Equivalent Circuit of a PV Cell

By maintaining a constant cell temperature, varying the resistance of the load, and measuring the produced current. Current-voltage (I-V) curves are obtained by exposing the cell to a constant level of light. I-V curve typically passes through two points:

Short-circuit current (I_{sc}):

I_{sc} is the current produced when the positive and negative terminals of the cell are short-circuited, and the voltage between

the terminals is zero, which corresponds to zero load resistance from Fig. 2

Open-circuit voltage (V_{OC}):

V_{OC} is the voltage across the positive and negative terminals under open-circuit conditions, when the current is zero, which corresponds to infinite load resistance from Fig.2

For simulink model we used another modified equivalent circuit of PV cell is shown below.

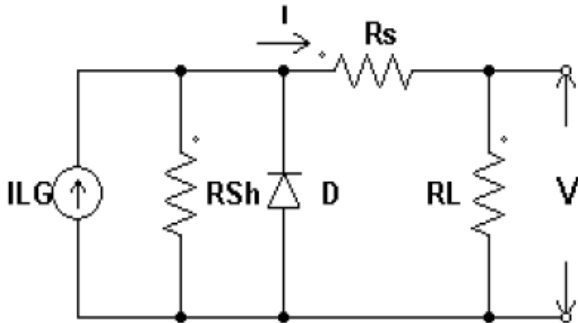

Fig.3 Modified Equivalent circuit of PV cell

The current-voltage relationship of a PV cell is given below:

$$I = I_{LG} - I_{OS} \left\{ \exp\left[\frac{q}{AKT}(V + IR_S)\right] - 1 \right\} \frac{V + IR_S}{R_{Sh}} \dots \dots (1)$$

Where,

$$I_{OS} = I_r \left(\frac{T}{T_r}\right)^3 \left\{ \exp\left[\frac{qE_{GO}}{BK}\left(\frac{1}{T_r} - \frac{1}{T}\right)\right] \right\} \dots \dots \dots (2)$$

$$I_{LG} = [I_{SCR} + K_1 (T-25) \lambda / 1000] \dots \dots \dots (3)$$

Where,

- I and V=cell output current and voltage
- Ios = cell reverse saturation current
- T = cell temperature in OC
- K = Boltzmann constant
- Q=electronic charge
- KI =0.0017 short circuit current temp coefficient at ISCR
- λ =Solar irradiation in W/m²
- I_{SCR} = short circuit current at 25 OC
- I_{LG} =light generated current
- E_{GO} = band gap for silicon
- B=A=1.92 ideality factors
- Tr= 301.18 OK reference temperature
- I_{or} = cell saturation current at Tr
- R_{sh} = shunt resistance
- Rs = series resistance

Fig. below show a single diode based model of PV module at constant isolation and temperature is developed in MATLAB with simulink library. This module is used as a source for the maximum power point tracker system[7] .In PV panel 36 cells are connected in series.

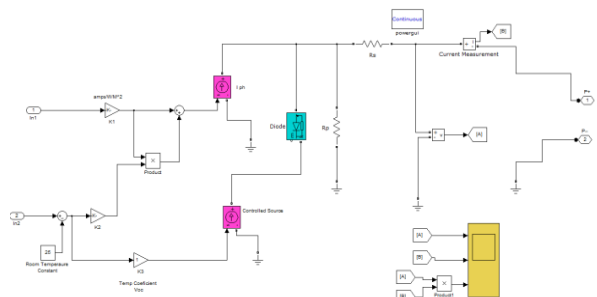

Fig.4 Simulink model of PV cell at constant radiation
As the isolation and temperature is kept constant, the output voltage, current is constant as shown in Fig.4

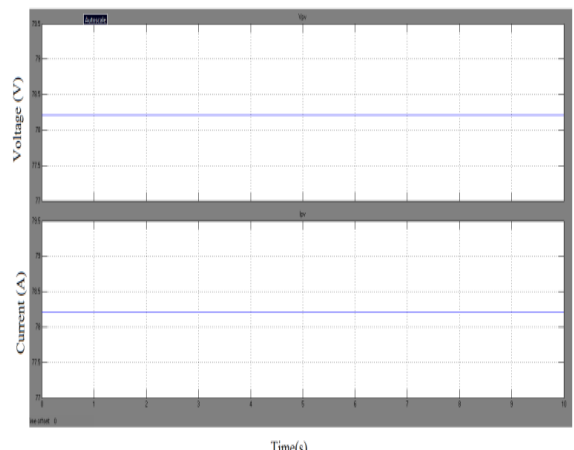

Fig. 5 Voltage-Current output of PV cell under constant radiation of above model.

Due to natural changes in weather the constant isolation and temperature are not practically possible , a solar cell or PV model with varying isolation and temperature were also designed. The variation in the inputs such as isolation and temperature are applied using repeat in sequence satire.

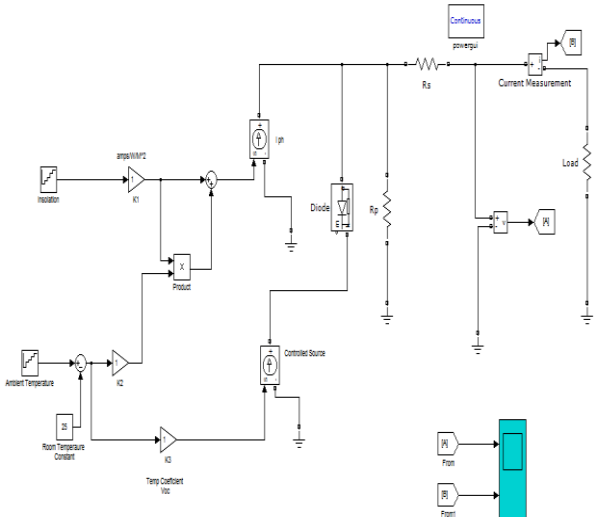
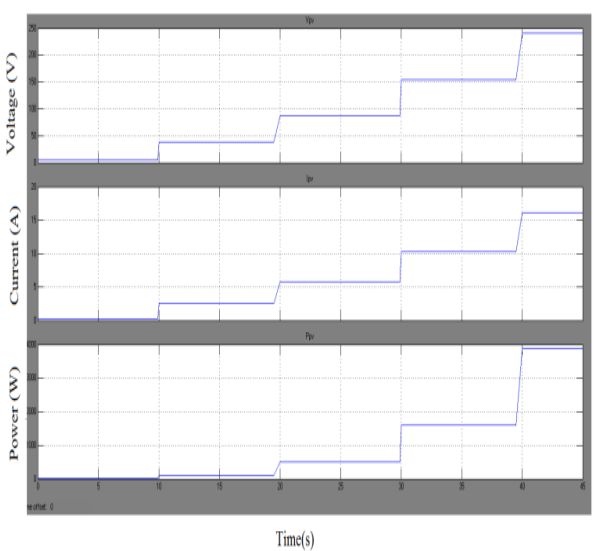

Fig. 5 Simulink model of PV cell (different radiation)



The output characteristics of PV module are simulated and shown in Fig. 6, using Simulink library in MATLAB. The changes in isolation affect the photon generated current and has very little effect on the open circuit voltage. Whereas the temperature variation affects the open circuit voltage and the short circuit current varies very marginally.

Table 1: Specification of PV module

II. MPPT METHOD USED

Constant Current:

The constant current method is based on the observation from I-V curves that the ratio of the module maximum current (I_{max}) to its short-circuit current, (I_{sc}), is approximately constant and it is given by

$$\frac{I_{max}}{I_{sc}} = K < 1 \dots \dots \dots (3)$$

As shown in (3), the ratio between currents of MPP and short circuit is controlled in CC algorithm. In application process, a switch is used that is located in beginning of a sentence.

PV array terminals or input of convertor to create a sudden short circuit by switching on it. In this case, short circuit current is measured, and current value of operating point is determined using of current factor K.[8]

In this method, first the short circuit current, I_{sc} is computed for the 10watt solar module. Then, it is multiplied by a current factor, K of suitable value (0.86 in this case) to obtain the current (I_{max})

Maximum Power (Pmax)	10.00 W
Open Circuit Voltage (Voc)	21.60 V
Short circuit current (Isc)	0.61 A
Rated Voltage (Vm)	17.64 V
Rated Current (Im)	0.57 A
Normal Operating temp of cell	47 ± 2 °C
Maximum Temp.	85 °C
Output Tolerance	± 3 %
Maximum System Voltage	600 UL/ 1000V IEC
Operating Temp.	-40 °c to 80 °c
Cell Technology	Poly-Si
Module Weight	1.5 KG
Module Dimension (mm)	350×40×18 MM

corresponding to the maximum power. For this fixed value of current, the power is computed for different voltages. If the difference between the power computed and the peak power is larger than the tolerance value, then value of voltage is either incremented or decremented depending on the power obtained. For that corresponding voltage and MPP current (I_{max}), this process is repeated till the difference is in the tolerance range. [8] The program flow chart for constant current algorithm is shown in Fig. 8

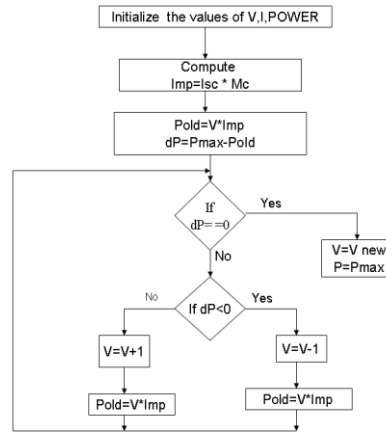

Fig. 7 constant current method algorithms

Constant voltage method:

In this method fixed value is considered for the MPP voltage equal to the value determine under the standard condition given by manufacturer. This methodology requires measuring the module voltage. It can be implemented in both digital and analog form. [9]

III. BLOCK DIGRAM OF AUTOMATED SOLAR IRRIGATION SYSTEM WITH MPPT

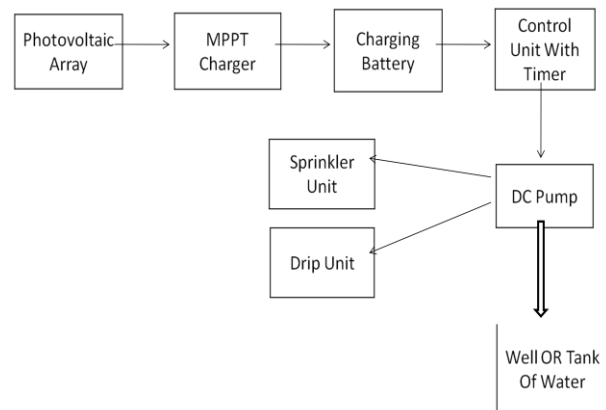

Fig. 8 Block diagram of whole system

A. PHOTOVOLTAIC MODULE

Photovoltaic module is a combination of PV cells. Photovoltaic module uses solar light energy to generate electricity through the photovoltaic effect. The majority of modules use wafer based cells or thin film cells based on non-magnetic conductive transition metals, telluride or silicon. The energy produce is depends upon the construction, frequencies of light from sun. However, the module failed to convert entire solar range specifically ultraviolet light diffused light. Hence lot of radiation wasted to compensate these waste we use MPPT & charge controller. The output from photovoltaic module is purely dc.

B. MPPT CHARGER

MPPT charger is the battery charged with a constant current that is generally one-tenth of the battery capacity in ampere-

hours. So for a 7Ah battery, constant charging current would be 70 mA. Battery rated at other rating can be charged by simply changing the values of the zener diodes. As per the battery capacity the constant current can be set with the pot meter. Quiescent current is less than 5 mA and mostly due to zener diodes. This circuit also provides protection against overvoltage and deep discharge.

Parameter	Values
type	Centrifugal
Power	10W
connection	1/2 " (inlet)&1/4 "(outlet)
Head	3.70 Meters (max)
Discharge	125 L.P.H. (max Head)
supply	12 V Pure DC
current	7A

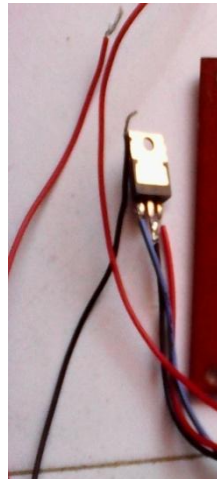

Fig. 8 MPPT based constant current battery charger.

In above circuit some important component we used is given below.

The LM136-5.0/LM236-5.0/LM336-5.0 integrated circuits are precision 5.0V shunt regulator diodes. These monolithic IC voltage references operate as a low temperature coefficient 5.0V zener with 0.6Ω dynamic impedance. A third terminal on the LM136-5.0 allows the reference voltage and temperature coefficient to be trimmed easily. The LM136-5.0 series is useful as a precision 5.0V low voltage reference for digital voltmeters, power supplies or op amp circuitry. The 5.0V makes it convenient to obtain a stable reference from low voltage supplies. Further, since the LM136-5.0 operates as a shunt regulator, it can be used as either a positive or negative voltage reference. The LM136-5.0 is rated for operation over -55°C to +125°C while the LM236-5.0 is rated over a -25°C to +85°C temperature range. The LM336-5.0 is rated for operation over a 0°C to +70°C temperature range.



Fig. 9 connection digram of LM-236-5 reference diode

These are N-Channel enhancement mode silicon gatepower field effect transistors. This type of powerMOSFETs designed, tested, and guaranteed to withstand aspecified level of energy in the breakdown avalanche modeof operation. Power MOSFETs are designed forapplications such as switching regulators, switching

convertors, motor drivers, relay drivers, and drivers for high power bipolar switching transistors requiring high speed and low gate drive power.

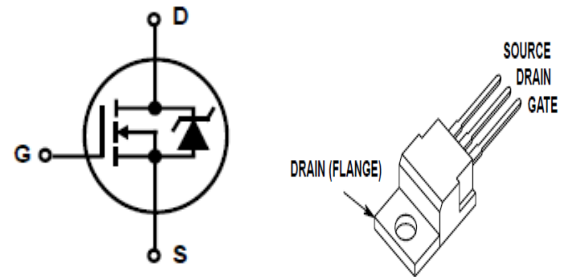

Fig. 10 Power MOSFET / IRF 540

C. CONTROL UNIT

The LM555 is a highly stable device for generating accurate time delays or oscillation. Additional terminals are provided for triggering or resetting if desired. In the time delay mode of operation, the time is precisely controlled by one external resistor and capacitor. For astable operation as an oscillator, the free running frequency and duty cycle are accurately controlled with two external resistors and one capacitor. The circuit may be triggered and reset on falling waveforms, and the output circuit can source or sink up to 200mA or driver TTL circuits. With this IC can we made the system automatic by setting the time for how much time it is required to be in operation.

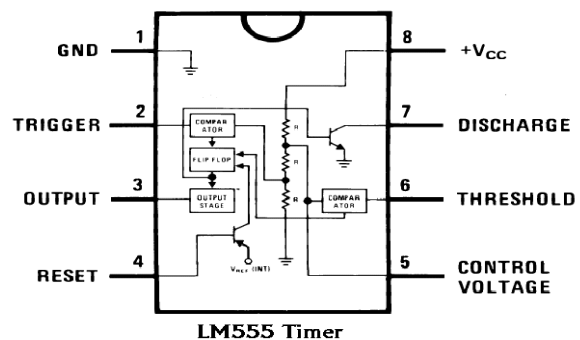

Fig. 11 LM 555 Timers

A.DC PUMP SPECIFICATION

The DC pump we used has the following specifications shown in table 2.

D. DC PUMP SPECIFICATION

The DC pump we used has the following specifications shown in table 2.

Approximate performance of 12V 7A DC pump at different heads given below table 3

REFERENCES

Head (feet)	4	8	12
Discharge (L.P.H)	280	210	160

IV. CONCLUSION

Thus in this paper, with the MATLAB 2010 simulink library modeled the solar cell at constant radiation and different radiation and we conclude that , when the isolation changes it affects on the photon generated current and has less effect on open circuit. Whereas the effect of temperature on the open circuit voltage and the short circuit current increase in temperature they increases very marginally. By using the MPPT based on constant current battery charger we can extract maximum power from PV module and it is stored in 12V, 7A battery and use it for 12V, 7A dc pump directly.

- [1] D. P. Hohm and M. E. Ropp, "Comparative Study of Maximum Power Point Tracking Algorithms," Progress in Photovoltaics, SD 5700-2220, November 2002.
- [2] Nevzat Onat, "Recent Developments in Maximum Power Point Tracking Technologies for Photovoltaic Systems," Hindawi Publishing Corporation International Journal of Photoenergy Volume 2010, Article ID 245316, doi:10.1155/2010/245316
- [3] Carles Jaen, Cristian Moyano, Xavier Santacruz, Josep Pou and Antoni Arias, "Overview of maximum power point tracking control techniques used in photovoltaic systems," IEEE transaction of Electronic Engineering Department, Technical University of Catalonia, 978-1-4244-2182, August 2008.
- [4] Mr. R. B. Darla, "Development of Maximum Power Point Tracker for PV Panels Using SEPIC Converter," IEEE transaction for amar raja power system, 978-1-4244-1628, June 2007.
- [5] Trishan Eeram, Patrick L. Chapman, "Comparison of Photovoltaic Array Maximum Power Point Tracking Techniques," IEEE transaction on energy conversion, vol. 22, NO. 2, June 2007
- [6] V. M. Pacheco, L. C. Freitas, J. B. Vieira Jr., E. A. A. Coelho and V. J. Farias, "Stand-Alone Photovoltaic Energy Storage System With Maximum Power Point Tracking," IEEE transaction 0-7803-7768, March 2003.
- [7] Pranita A. Bhosale, Prof. V. V. Dixit, "Water Saving-Irrigation Automatic Agricultural Controller," IJSTR vol 1, ISSN 2277-8616, December 2012.
- [8] Pradeepa, S., Hariharan, R. and Ajay, R., "STANDALONE MICROGRID USING PV ARRAY WITH CSI," International Journal of Development Research Vol. 4, Issue, 3, pp. 642-646, March 2014.
- [9] Mohammed Ali Elgendy, Bashar Zahawi, "Comparison of Directly Connected and Constant Voltage Controlled Photovoltaic Pumping Systems," IEEE Transaction on Sustainable Energy, vol. 3, October 2010.

