

Speed Control of Induction Motor using Cycloconverter

Mruganka Gulhane¹, Pratiksha Mahure², Saurabh Bhagat³, Saurabh Naitam⁴

¹²³⁴(Student of EE Department) K.D.K.C.E, Nandanwan, Nagpur. (M.H).
¹³mrugankagulhane@gmail.com, ²pratikshamahure5@gmail.com,

Abstract

The project is designed to control the speed of a single phase induction motor in three steps by using cyclo converter technique by thyristors. A.C. motors have the great advantages of being relatively inexpensive and very reliable. Induction motors in particular are very robust and therefore used in many domestic appliances such as washing machines, vacuum cleaners, water pumps, and used in industries as well. The induction motor is known as a constant-speed machine, the difficulty of varying its speed by a cost effective device is one of its main disadvantages.

As the AC supply frequency cannot be changed, so this project uses a thyristors controlled cycloconverter which enables the control of speed in steps for an induction motor. The microcontroller used in this project is from 8051 family, a pair of slide switches is provided to select the desired speed range (F, F/2 and F/3) of operation of the induction motor. These switches are interfaced to the microcontroller. The status of the switches enables the microcontroller to deliver the pulses to trigger the SCR's in a dual bridge. Thus, the speed of the induction motor can be achieved in three steps i.e. (F, F/2 and F/3).

This very concept can be further enhanced and implemented to control the speed of a three phase induction motor. It can also be coupled with firing angle control for any desired speed.

Keywords: Cycloconverter, Voltage regulator, zero crossing detection, induction motor control, 8051 microcontroller

I. Introduction

Cycloconverter are used in high power applications driving induction and synchronous motors. They are usually phase-controlled and they traditionally use thyristors due to their ease of phase commutation. Power conversion systems such as those used for large propulsion motor drives will often utilize cycloconverter technology in order to take advantage of the power handling capability of modern thyristors. Because cycloconverter produce non-integer harmonics of the input power frequency, both input current and output voltage require detailed study in order to insure trouble-free operation of both the supplying power system and the connected motor load. The cycloconverter is a device which converts input AC power at one frequency to output AC power at a different frequency with a one stage conversion. The frequency conversion is achieved using a phase control method. Phase controlled cycloconverter have the ability to operate in all 4 quadrants in the V-I plane. Thus, cycloconverter are capable of providing a variable frequency power supply to AC machines. Due to its 4-quadrant operation, the cycloconverter can handle loads of any power factor. The cycloconverter also allows power to flow freely in either direction. Over most of its range, the cycloconverter produces a reasonable sine wave output that leads to good output performance, particularly at lower frequencies. Traditionally, satisfactory performance has been understood to be available when the output frequency is up to approximately 40 percent of the input frequency (e.g. 24 hertz output from a 60 hertz supply). Above this output frequency, the waveforms become more distorted due to interaction between the mains and

output frequencies. The cycloconverter performance deteriorates progressively as output frequency increases.

The switching of the AC waveform creates noise, or harmonics, in the systems that depend mostly on the frequency of the input waveform. These harmonics can damage sensitive electronic equipment. If the relative difference between the input and output waveforms are small, then the converter can produce subharmonics. Subharmonic noise occurs at a frequency below the output frequency, and cannot be filtered by load inductance. This limits the output frequency relative to the input. These limitations make cycloconverter often inferior to a DC link converter system for most applications.

II. VOLTAGE REGULATOR

The LM7805 series of three-terminal positive regulators are available in the TO-220/D-PAK package and with several fixed output voltages, making them useful in a Wide range of applications. Each type employs internal current limiting, thermal shutdown and safe operating area protection, making it essentially indestructible. If adequate heat sinking is provided, they can deliver over 1A output Current. Although designed primarily as fixed voltage regulators, these devices can be used with external components to obtain adjustable voltages and currents.

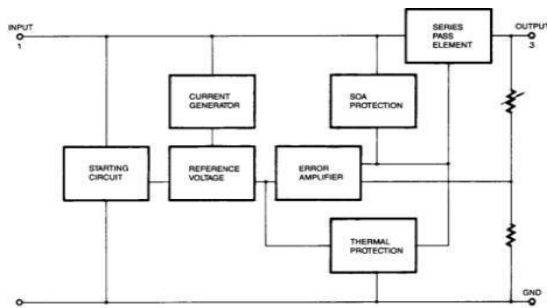

Fig1 (a) Block diagram of voltage regulator

Parameter	Symbol	Value	Unit
Input Voltage (for $V_O = 5V$ to $18V$)	V_I	35	V
(for $V_O = 24V$)	V_I	40	V
Thermal Resistance Junction-Cases (TC-220)	$R_{\theta JC}$	5	$^{\circ}C/W$
Thermal Resistance Junction-Air (TC-220)	$R_{\theta JA}$	65	$^{\circ}C/W$
Operating Temperature Range (KA78XX/A/R)	T_{OPR}	$0 \sim +125$	$^{\circ}C$
Storage Temperature Range	T_{STG}	$-65 \sim +150$	$^{\circ}C$

Fig1 (b) Absolute Maximum Ratings

- It has some features:
- Output Current up to 1A.
- Output Voltages of 5, 6, 8, 9, 10, 12, 15, 18, 24V.
- Thermal Overload Protection.
- Short Circuit Protection.
- Output Transistor Safe Operating Area Protection.

III. ZERO CROSSING DETECTION

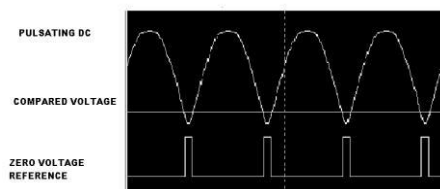
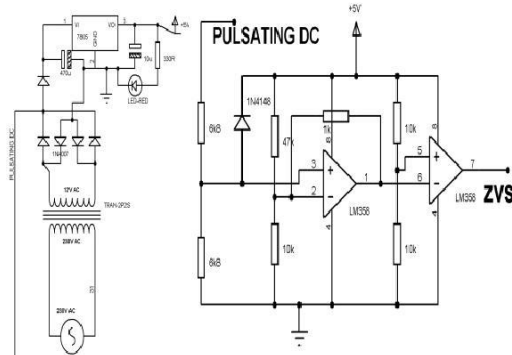

Voltage for every 10msec of a 20msec cycle. We are using 50Hz ac signal, the total cycle time period is 20msec ($T=1/F=1/50=20msec$) in which, for every half cycle (i.e. 10ms) we have to get zero signals. This is achieved by using pulsating dc after the bridge rectifier before being filtered. For that purpose we are using a blocking diode D3 between pulsating dc and the filter capacitor so that we can get pulsating DC for use. The pulsating DC is given to potential divider of 6.8k and 6.8K to deliver an output about 5V pulsating from 12V pulsating which is connected to non-inverting input of comparator pin 3. Here Op-amp is used as comparator. The 5V DC is given to a potential divider of 47k and

Voltage Reference) detection. This ZVR is then used as input pulses to microcontroller.

The output of power supply which is 5v is connected to the 40th pin of microcontroller and gnd to the 20th pin or pin 20 of microcontroller. Pin 2.0 of port 2 of MC is connected to 1st pin i.e., anode of 1st MOC3021. Pin 2.1 of port 2 of MC is connected to anode pin of 2nd MOC3021. Pin 2.2 of port 2 of MC is connected to anode pin i.e., 1st pin of 3rd MOC3021. Pin 2.3 of port 2 of MC is connected to anode pin i.e., 1st pin of 4th MOC3021. Pin 2.4 of port 2 of MC is connected to anode pin i.e., 1st pin of 5th MOC3021. Pin 2.5 of port 2 of MC is connected to anode pin i.e., 1st pin of 6th MOC3021. Pin 2.6 of port 2 of MC is connected to anode pin i.e., 1st pin of 7th MOC3021. Pin 2.7 of port 2 of MC is connected to anode pin i.e., 1st pin of 8th MOC3021. Pin 3.3 of port 2 of MC is connected to output of LM358. pin 1.0 & pin .1 of port 1 of MC are given to SW₁ & SW₂ (switch 1 & switch 2).

Working:

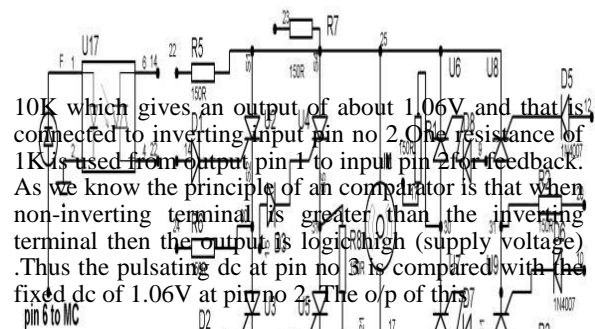

Fig 5.1.3 thyristor switching by zvs

The project uses zero voltage reference as described above at pin no.13 i.e., port 3.3, interrupt – 1. Eight Opto – isolators i.e., MOC3021 are used for driving 8 SCR's U2 to U9. 4 SCR's used in full bridge are in anti-parallel with another set of 4 SCR's as shown in the diagram. Triggering pulses so generated by the MC as per the program written provides input condition to the Opto – isolator that drive the respective SCR. Only one Opto U17 driving the scr U2 is shown above while all other are similar as per the circuit diagram. SCR gets conducting for 20ms from 1st bridge and next 20ms from the 2nd bridge to get the output at point no – 25 & 26, total time period of one AC cycle of 40ms which is 25 Hz. Thus F/2 is delivered to the load

while switch 1 is closed. Similarly for $F/3$ the conduction takes place for 30ms in the 1st bridge and next 30ms from the next bridge, such that a total time period of 1 cycle comes to 60ms which in turn in $F/3$ while switch -2 is operated. Fundamental frequency of 50Hz is available by triggering on pair from the 1st bridge for 1st 10ms and for the next 10ms from the next bridge while both the switches are kept in

“OFF” condition. Reverse current flowing in the gates of the SCR’s are Opto – isolator output.

The input dc shall be varying in the event of input ac at 230volts section varies from 160V to 270V in the ratio of the transformer primary voltage V_1 to secondary voltage V_2 governed by the formula $V_1/V_2=N_1/N_2$. As N_1/N_2 i.e. no. of turns in the primary to the no. of turns in the secondary remains unchanged V_2 is directly proportional to V_1 .

The regulated 5V DC is further filtered by a small electrolytic capacitor of $10\mu\text{F}$ for any noise so generated by the circuit. One LED is connected of this 5V point in series with a current limiting resistor of 330Ω to the ground i.e., negative voltage to indicate 5V power supply availability.

IV. SCHEMATIC DIAGRAM

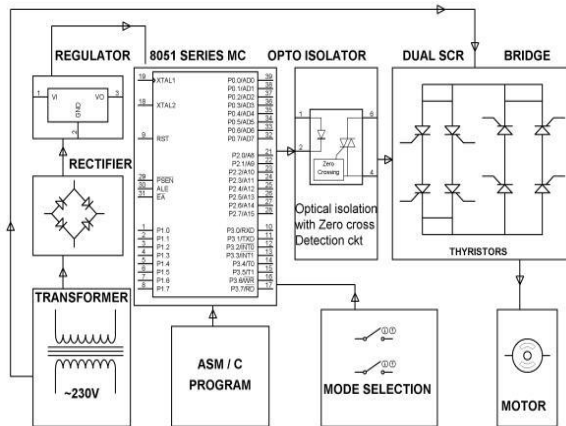

Fig.(a) Block diagram of cycloconverter using thyristors

Description:

single phase 230 V Power supply is given the transformer for step down the voltage from 230v AC to 12V AC. The 12v AC is then fed to the bridge rectifier. The rectifier converts 12V ac to 12VDC. output of the rectifier is fed to the Voltage regulator 7805 it gives the output of 5V DC. The 5V DC is given to V_{cc} of the micro controller 8051. The micro controller has been programmed i.e. ASM/C program to give output to optical isolation with zero cross detection circuit. It compares two signals in order to get zero crossing whenever the zero crossing occurs it gives an output. . A microcontroller program is developed to control the firing pulses of gate driving circuit, these firing pulses are controlled by DIACs. The output of the cycloconverter is fed to the induction motor to control the speed at different frequencies.

Cycloconverter circuit diagram is as shown in figure 3. The circuit uses standard power supply comprising of a step-down transformer from 230V to 12V and 4 diodes forming a full-bridge rectifier that delivers pulsating dc which is then filtered with LC filter of $470\mu\text{F}$ to $1000\mu\text{F}$. To regulate the dc power supply, IC LM7805 is used to get constant 5V DC its pin no 3 irrespective of input DC varying from 7V to 15V.

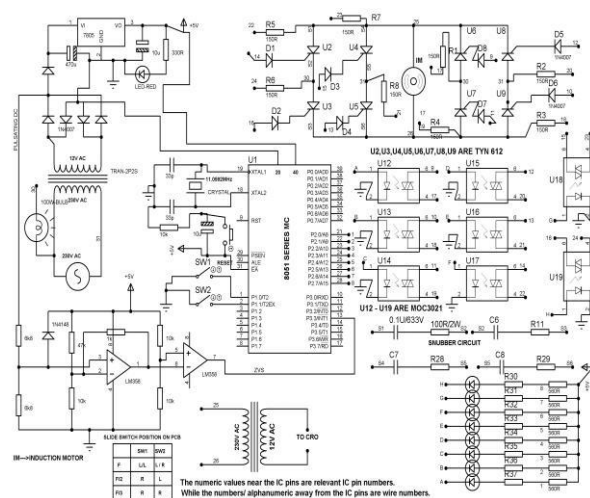

Fig.(b) Schematic Diagram

Operation:

Cycloconverter consists of two single phase full bridge circuits bridge 1 and bridge 2, load is connected in between these two bridge circuits as shown in figure. Each bridge consists of four thyristors. From these upper group thyristors are positive and lower group are negative group thyristors. These thyristors gate pulses are controlled by zero crossing detector and microcontroller. The firing angle control consists of eight MOC 3021 Opto isolators. MOC 3021 contains a LED and a light sensitive DIAC.

When the LED is switched on then the DIACs in MOC3021 get the input and they turn on. The Opto isolator (MOC 3020) isolates the high frequency modulated driver control circuit with low frequency cycloconverter circuit.

At time $t=0^+$ the thyristors on the 1st bridge to switch on for pre-defined time period t_1 , during this time period t_1 other bridge is kept off position.

To control the speed of the induction motor frequency control of the output voltage by turn-on and turn- Off time periods of the thyristors.

. When the switch 1 is closed SCR gets conducting for 20ms for 1st bridge and next 20ms for 2nd bridge so the total time period of AC cycle is 40ms so it gives the frequency 25Hz i.e. F/2.

When the switch 2 is closed the time period of conduction for the 1st bridge takes place for 30ms and then other bridge for 30ms. so the total time period of AC cycle is 60ms 16.66 Hz i.e. F/3. This supply is given to the motor by using F/2 and F/3 supply we can control the speed of the AC motor.

V. HARDWARE CIRCUIT

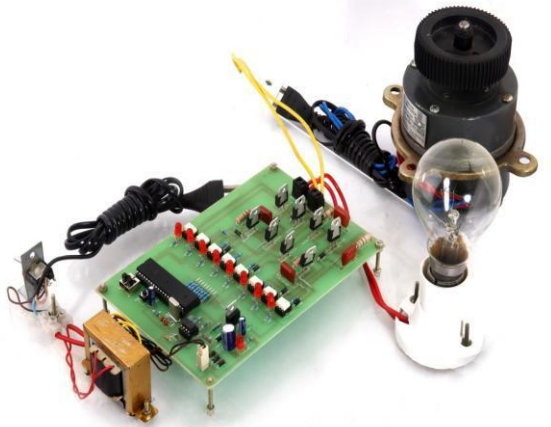

Fig.6.1. Picture of the cycloconverter using thyristor

Fig 6.4 output at load for frequency $F=16.66 \text{ Hz}$ i.e. $F/3$

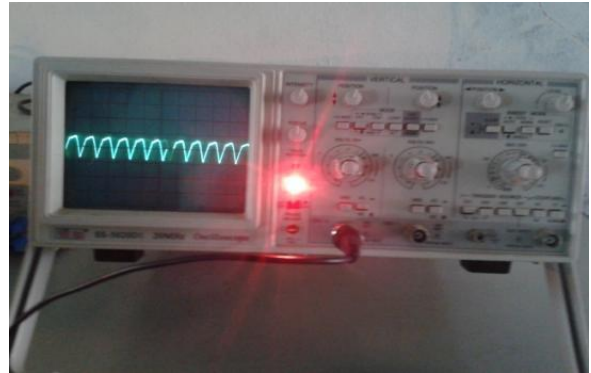

Fig 6.5 rippled DC (rectifier output)

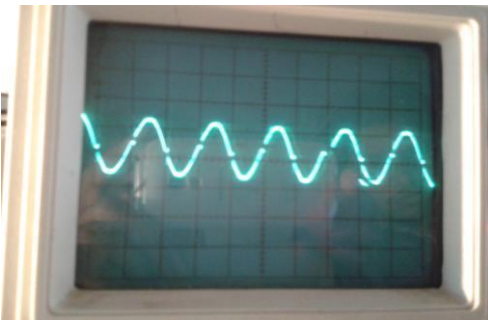

Fig 6.2. 12v AC (output of 230v/12v transformer)

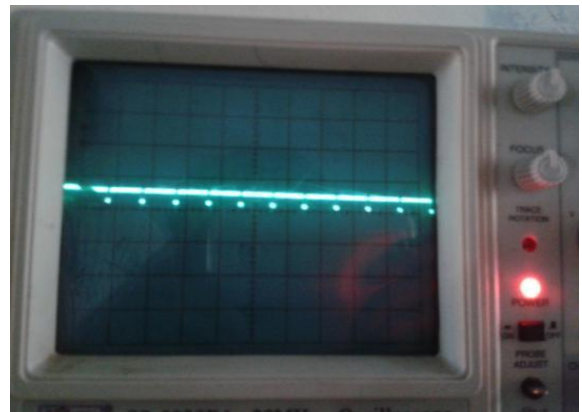

Fig 6.6 Zero voltage sensing pulses

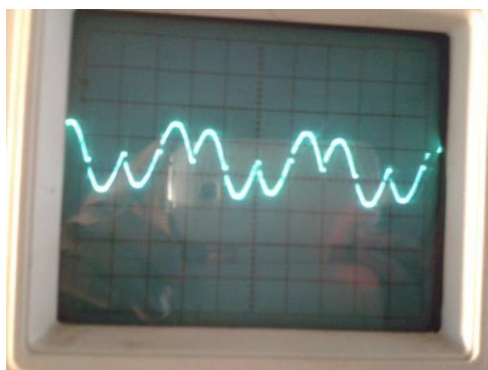

Fig 6.3 output at load for frequency $F=25 \text{ Hz}$ i.e. $F/2$

VI. RESULTS

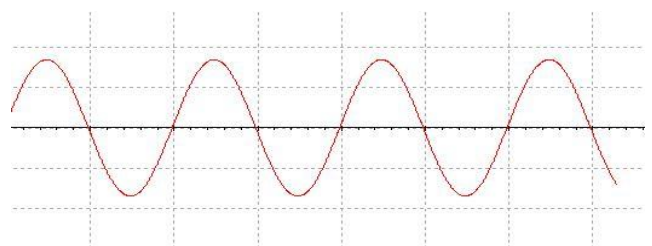

Fig 7.2: 12v AC (output of 230v/12v transformer)

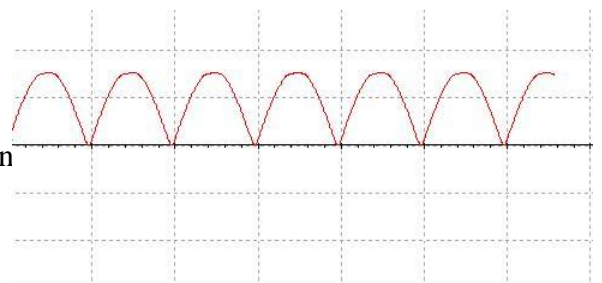
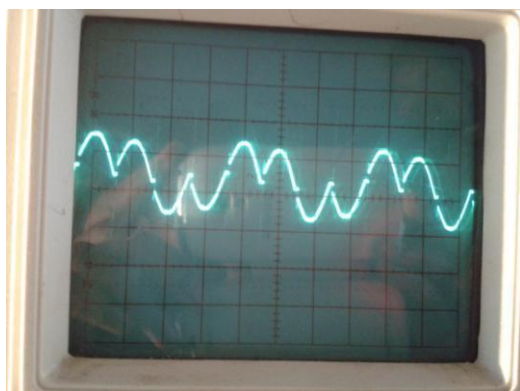

Fig 7.3 rippled DC (rectifier output)

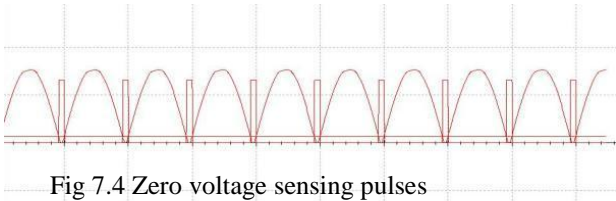

Fig 7.4 Zero voltage sensing pulses

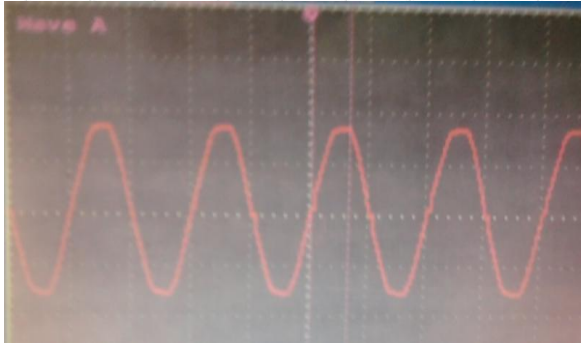

Fig 7.5 output at load for normal frequency $F=50\text{Hz}$



7.6 Fig output at load for frequency $F=25\text{Hz}$ i.e $F/2$

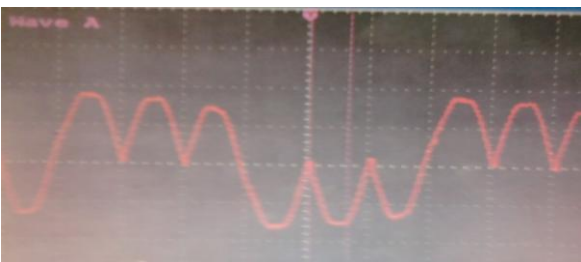

Fig 7.7 output at load for frequency $F=16.66\text{ HZ}$ ie $F/3$

VII. CONCLUSION

In manufacturing and process industries, the variable frequency is required for driving various electrical machineries. The cycloconverter or variable frequency generator plays a significant role in driving those electrical machineries. The study mainly focuses on the design and construction of the single phase cycloconverter. The commercially designed single phase cycloconverter circuit may use different design pattern than this one. This single phase

cycloconverter circuit can be extended further for three phase application. In case of the three phase cycloconverter, each of the positive and negative converter group operates for half the period of the output frequency.

REFERENCES

- [1] J. Zhang, "Single phase input cycloconverter driving an induction motor" Ph.D. thesis, University of Technology, Sydney,
- [2] G. L. Arsov, "Improvements in microcomputer-based digital control of cycloconverter", IEEE Trans. Ind. Appl., vol. IA-30, no. 3, pp. 585-588, May/June 1994.
- [3] J. Zhang, G.P. Hunter and V.S. Ramsden, "A single phase input cycloconverter driving a three phase motor", 5th European Conference on Power Electronics, EPE'93, Brighton, UK, 14-17 September 1993
- [4] V.S. Ramsden, G.P. Hunter and J. Zhang "Impact on the power system of single phase input cycloconverter motor drives" IEE Proc.-Elect. Power Appl., Vol. 142 No. 3, May 1995, pp. 176-182.
- [5] Power Electronics by M.D.Singh & K.B.Khanchandani.
- [6] Power Electronics by P.S.Bhimra.

