

Voltage Source Converter Based HVDC Transmission

Ankit Khode¹, S.R.Gawande²,Kuldeep wadaskar³,Sunil Jambhule⁴

K.D.K. College of Engineering

¹ankit07khode@gmail.com

Abstract - High Voltage Direct Current system based on Voltage Source Converters (VSC-HVDC) is becoming a more effective, solution for long distance power transmission especially for off-shore wind plants and supplying power to remote regions. Since VSCs do not require commutating voltage from the connected ac grid, they are effective in supplying power to isolated and remote loads. Due to its advantages, it is possible that VSC-HVDC will be one of the most important components of power systems in the future. Power transmission using AC system over the past years has proven to be robust and efficient. One main problem with respect to AC power transmission is the complexities involved in precise power controllability. This problem may be overcome by using VSC based HVDC system of transmission. In the present work, possibility of using VSC based HVDC transmission for evacuating power is explored.

Keywords – Voltage source converter, Control Strategy, HVDC cables, filters, Converters

I. INTRODUCTION

Conventional HVDC transmission employs line-commutated, current-source converters with Thyristor valves. These converters require a relatively strong synchronous voltage source in order to commute. The conversion process demands reactive power from filters, shunt banks, or series capacitors, which are an integral part of the converter station. Any surplus or deficit in reactive power must be accommodated by the ac system.

The development of power semiconductor devices, especially IGBT's has led to the transmission of power based on Voltage source converters (VSCs). The VSC based HVDC installation has several advantages compared to conventional HVDC such as, independent control of active and reactive power, dynamic voltage support at the converter bus for enhancing stability possibility to feed to weak AC systems or even passive loads,

reversal of power without changing the polarity of dc voltage (advantageous in multi terminal dc system) and no requirements or fast communication between the two converter stations. HVDC light is also called voltage source converter HVDC or VSC HVDC. HVDC light can control both active and reactive power independently without commutation failure in the inverters. Each converter station is composed of a VSC. This difference in reactive power needs to be kept within a given band to keep the ac voltage within the desired tolerance. The weaker the system or the further away from generation, the tighter the reactive power exchange must be to stay within the desired voltage tolerance. HVDC transmission using voltage-source converters (VSC) with pulse-width modulation (PWM) was introduced as HVDC Light in the late 1990s by ABB. These VSC-based systems are force-commutated with insulated-gate bipolar transistor (IGBT) valves and solid-dielectric, extruded HVDC cables HVDC transmission and reactive power compensation with VSC technology has certain attributes which can be beneficial to overall system performance. VSC converter technology can rapidly control both active and reactive power independently of one another. Reactive power can also be controlled at each terminal independent of the dc transmission voltage level. This control capability gives total flexibility to place converters anywhere in the ac network since there is no restriction on minimum network short-circuits capacity. Forced commutation with VSC even permits black start, that is, the converter can be used to synthesize a balanced set of 3-phase voltages like a virtual synchronous generator. The dynamic support of the ac voltage at each converter terminal improves the voltage stability and increases the transfer capability of the sending and receiving end ac systems. In the present work, possibility of using VSC based HVDC transmission for evacuating power is been explored.

II. VSC HVDC SYSTEM

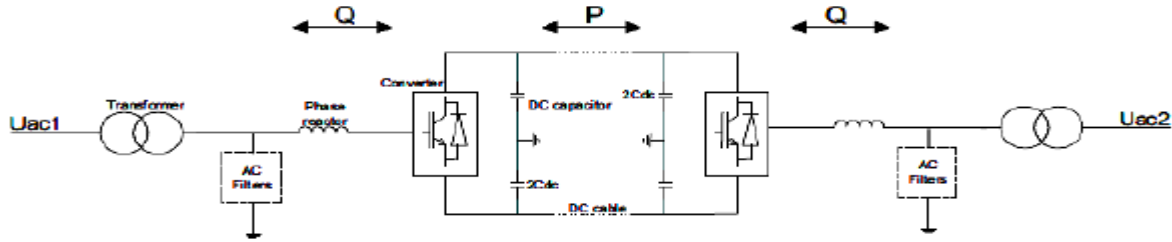

Fig1.Configuration of a VSC-HVDC System

The configuration of a VSC-HVDC system shown in Figure consists of ac filters, transformers, converters, phase reactors, dc capacitors and dc cables.

B. Components of VSC-HVDC System and its operation

VSC-HVDC is a new dc transmission system technology. It is based on the voltage source converter, where the valves are built by IGBTs and PWM is used to create the desired voltage waveform. With PWM, it is possible to create any waveform (up to a certain limit set by the switching frequency), any phase angle and magnitude of the fundamental component. Changes in waveform, phase angle and magnitude can be made by changing the PWM pattern, which can be done almost instantaneously. Thus, the voltage source converter can be considered as a controllable voltage source. This high controllability allows for a wide range of applications. From a system point of view VSC-HVDC acts as a synchronous machine without mass that can control active and reactive power almost instantaneously. In this chapter, the topology of the investigated VSC-HVDC is discussed. Design considerations and modeling aspects of the VSC-HVDC are given. The topology selection for the VSC-HVDC is based on the desired capabilities.

C. Physical Structure

The main function of the VSC-HVDC is to transmit constant DC power from the rectifier to the inverter. As shown in Figure1, it consists of dc-link capacitors C_{dc} two converters, passive high-pass filters, phase reactors, transformers and dc cable. [7]

1. Physical Structure: The main function of the VSC-HVDC is to transmit constant DC power from the rectifier to the inverter. As shown in Figure.1, it consists of dc-link capacitors C_{dc} , two converters,

Passive high-pass filters, phase reactors, transformers and dc cable. [7]

2. Converters: The converters are VSCs employing IGBT power semiconductors, one operating as a rectifier and the other as an inverter. The two converters are connected either back-to-back or through a dc cable, depending on the application.

3. Transformers: Normally, the converters are connected to the ac system via transformers. The most important function of the transformers is to transform the voltage of the ac system to a value suitable to the converter. It can use simple connection (two-winding instead of three to eight-winding transformers used for other schemes). The leakage inductance of the transformers is usually in the range 0.1-0.2p.u. [7]

4. Phase Reactors: The phase reactors are used for controlling both the active and the reactive power flow by regulating currents through them. The reactors also function as ac filters to reduce the high frequency harmonic contents of the ac currents which are caused by the switching operation of the VSCs. The reactors are essential for both active and reactive power flow, since these properties are determined by the power frequency voltage across the reactors. The reactors are usually about 0.15p.u. Impedance.

5. AC Filters: The ac voltage output contains harmonic components, derived from the switching of the IGBTs. These harmonics have to be taken care of preventing them from being emitted into the ac system and causing malfunctioning of ac system equipment or radio and telecommunication disturbances. High-pass filter branches are installed to take care of these high order harmonics. With VSC converters there is no need to compensate any reactive power consumed by the converter itself and the current harmonics on the ac side are related directly to the PWM frequency. The amount of low-order harmonics in the current is small. Therefore the amount of filters in this type of converters is reduced dramatically compared with natural commutated converters. This is described in section 3.6 in detail.

6. Dc Capacitors: On the dc side there are two

capacitor stacks of the same size. The size of these capacitors depends on the required dc voltage. The objective for the dc capacitor is primarily to provide a low inductive path for the turned-off current and energy storage to be able to control the power flow. The capacitor also reduces the voltage ripple on the dc side.

7. Dc Cables: The cable used in VSC-HVDC applications is a new developed type, where the insulation is made of an extruded polymer that is particularly resistant to dc voltage. Polymeric cables are the preferred choice for HVDC, mainly because of their mechanical strength, flexibility, and low weight.

8 IGBT Valves: The insulated gate bipolar transistor (IGBT) valves used in VSC converters are comprised of series-connected IGBT positions. The IGBT is a hybrid device exhibiting the low forward drop of a bipolar transistor as a conducting device. Instead of the regular current controlled base, the IGBT has a voltage-controlled capacitive gate, as in the MOSFET device. A complete IGBT position consists of an IGBT, an anti parallel diode, a gate unit, a voltage divider, and a water-cooled heat sink. Each gate unit includes gate-driving circuits, surveillance circuits, and optical interface. The gate-driving electronics control the gate voltage and current at turn-on and turn-off, to achieve optimal turn-on and turn-off processes of the IGBT. To be able to switch voltages higher than the rated voltage of one IGBT, many positions are connected in series in each valve similar to thyristors in conventional HVDC valves. All IGBTs must turn on and off at exactly the same moment, to achieve an evenly distributed voltage across the valve. Higher currents are handled by paralleling IGBT components or press packs.

9 AC Grid: Usually a grid model can be developed by using the Thevenin's equivalent circuit. However, for simplicity, the grid was modeled as an ideal symmetrical three-phase voltage source.

D. Converter Topology:

The converters so far employed in actual transmission applications are composed of a number of elementary converters, that is, of three-phase, two-level, six-pulse bridges, as shown in Fig.2, or three phase, three-level, 12-pulse bridges, as shown in Fig

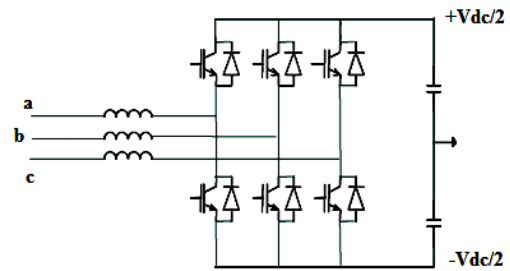

Fig .2 Two level VSC

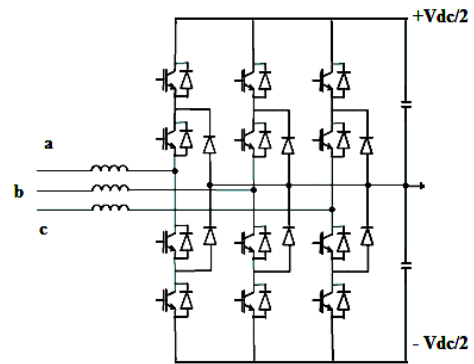

Fig3.Three level VSC

The two-level bridge is the Most Simple circuit Configuration that can be used for building up a three-Phase forced commutated VSC bridge. It has been widely used in many applications at a wide range of power levels. As shown in Figure 2, the two-level converter is capable of generating the two-voltage levels $-0.5.V_{dc}N$ and $+0.5.V_{dc}N$. The two-level bridge consists of six valves and each valve consists of an IGBT and an anti-parallel diode. In order to use the two-level bridge in high power applications series connection of devices may be necessary and then each valve will be built up of a number of series connected turn-off devices and anti-parallel diodes. The number of devices required is determined by the rated power of the bridge and the power handling capability of the switching devices. With a present technology of IGBTs a voltage rating of 2.5kV has recently become available in the market and soon higher voltages are expected. The IGBTs can be switched on and off with a constant frequency of about 2 kHz. The IGBT valves can block up to 150kV. A VSC equipped with these valves can carry up to 800A ac line current.

E. Harmonic filtering:

As described above, due to the commutation valve switching process, the currents and the voltages at the inverter and rectifier are not sinusoidal. These non-sinusoidal current and voltage waveforms consist of the fundamental frequency ac component plus higher-order harmonics. Passive high-pass ac filters are essential components of the VSC-HVDC topology to filter the high harmonic components. Hence, sinusoidal line currents and voltages can be obtained from the transformer secondary sides. Furthermore, the reactive power compensation may be accomplished by high-pass filters. When designing the high damping filters the quality factor Q is chosen to obtain the best characteristic over the required frequency band. There is no optimal Q with tuned filters. The typical value of the quality factor Q is between 0.5 and 5.

F.Design of DC Capacitor:

The design of dc side capacitor is an important part for the design of an HVDC system. Due to PWM switching action in VSC-HVDC, the current flowing to the dc side of a converter contains harmonics, which will result in a ripple on the dc side voltage. The magnitude of the ripple depends on the dc side capacitor size and on the switching frequency. The design of the dc capacitor should not only be based on the steady-state operation. During disturbances in the ac system (faults, switching actions) large power oscillations may occur between the ac and the dc side. This in turn will lead to oscillations in the dc voltage and dc over voltages that may stress the valves. It is important to consider the transient voltage variation constraint when the size of the dc capacitors is selected. Here, a small dc capacitor C_{dc} can be used, which should theoretically result in faster converter response and to provide an energy storage to be able to control the power flow. The dc capacitor size is characterized as a time constant τ , defined as the ratio between the stored energy at the rated dc voltage and the nominal apparent power of the converter

Where U_{dcN} denotes the nominal dc voltage and S_N stands for the nominal apparent power of the converter. The time constant is equal to the time needed to charge the capacitor from zero to rated voltage U_{dcN} if the converter is supplied with a constant active power equal to S_N . The time constant τ can be selected less than 5ms to satisfy small ripple and small transient over voltage on the dc voltage, which will be verified in the simulation. This relatively small time constant allows fast control of active and reactive power. Controller speed of less than 5ms is not practical because the connection will not react. This holds for the control of active power,

not for the control of reactive power. Reactive power is generated locally and does not require the dc link.

III. CONTROL SYSTEM

The transfer of energy is controlled in the same way as for a classical HVDC connection: the rectifier side controls the dc voltage; the inverter side controls the active power. Like with classical HVDC the power flow can be in either direction. With classic HVDC the reactive power cannot be controlled independently of the active power. With VSC-HVDC there is an additional degree of freedom. VSC-HVDC using PWM technology makes it possible to control the reactive power and the active power independently. The reactive power flow can be controlled separately in each converter by the ac voltage that is requested or set manually without changing the dc voltage. The active power flow can be controlled by dc voltage on the dc side or the variation of frequency of ac side, or set manually. Thus, the active power flow, the reactive power flow, the ac voltage, the dc voltage and the frequency can be controlled when using VSC-HVDC. The control system of the VSC-HVDC is based on a fast inner current control loop controlling the ac current. The ac current references are supplied by the outer controllers. The outer controllers include the dc voltage controller, the ac voltage controller, the active power controller, the reactive power controller or the frequency controller. The reference value of the active current can be derived from the dc voltage controller, the active power controller and the frequency controller, the reference value of the reactive current can be obtained from the ac voltage controller, the reactive power controller. In all these controllers, integrators can be used to eliminate the steady state errors. For example, as shown in Figure 1, either side of the link can choose between ac voltage control and reactive power control. Each of these controllers generates a reference value for the inner current controller. The inner current controller calculates the voltage drop over the converter reactor that will lead to the desired current. Obviously not all controllers can be used at the same time. The choice of different kinds of controllers to calculate the reference values of the converter current will depend on the application and may require some advanced power system study. For example: the active power controller can be used to control the active power to/from the converter; the reactive power controller can be used to control the reactive power; the ac voltage controller which is usually used when the

system supplies a passive network can be used to keep the ac voltage. If the load is a passive system, then VSC-HVDC can control frequency and ac voltage. If the load is an established ac system, then the VSC-HVDC can control ac voltage and power flow. But it should be known that because the active power flow into the dc link must be balanced, the dc voltage controller is necessary to achieve power balance. Active power out from the network must equal the active power into the network minus the losses in the system; any difference would mean that the dc voltage in the system will rapidly change. The other converters can set any active power value within the limits for the system. The dc voltage controller will ensure active power balance in all cases.

IV.SIMULATION

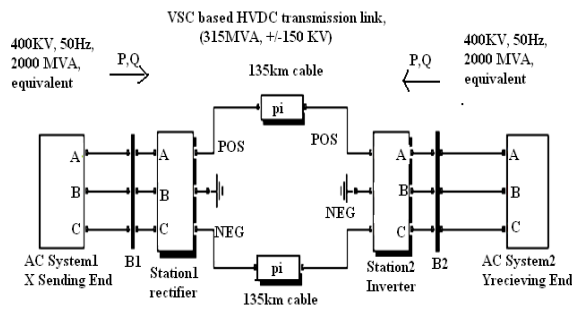

Fig 4 VSC based HVDC transmission link

System Description:

A 300 MW (± 150 kV) forced-commutated voltage-sourced converter (VSC) interconnection is used to transmit DC power from a 400 kV, 2000 MVA, 50 Hz system to another identical AC system [17]. The AC systems (1 and 2) are modelled by damped L-R equivalents with an angle of 80 degrees at fundamental frequency and at the third harmonic. The rectifier and the inverter are three-level Neutral Point Clamped (NPC) VSC converters using close IGBT/Diodes. The rectifier and the inverter are interconnected through a 125 km cable (i.e. 2 pi sections) and two 8 mH smoothing reactors. The sinusoidal pulse width modulation (SPWM) switching uses a single-phase triangular carrier wave with a frequency of 27 time’s fundamental frequency (1350 Hz). A converter transformer (wye grounded /Delta) is used to permit the optimal voltage transformation. The present winding arrangement blocks triiple harmonics produced by the converter. The 0.15 pu phase reactor with the 0.15 pu transformer leakage reactance permits the VSC output voltage to shift in phase and amplitude with

respect to the AC system Point of Common Coupling (PCC) and allows control of converter active and reactive power output. The tap position is rather at a fixed position determined by a multiplication factor applied to the primary nominal voltage of the converter transformers. The multiplication factors are chosen to have a modulation index around 0.85 (transformer ratios of 0.915 on the rectifier side and 1.015 on the inverter side). To meet AC system harmonic specifications, AC filters form an essential part of the scheme. They can be connected as shunt elements on the AC system side or the converter side of the converter transformer. Since there are only high frequency harmonics, shunt filtering is therefore relatively small compared to the converter rating. The 78.5 Mvar shunt AC filters are 27th and 54th high-pass tuned around the two dominating harmonics

Simulations Results: The simulation results at the sending end X and receiving end Y are illustrated in the following Figures.

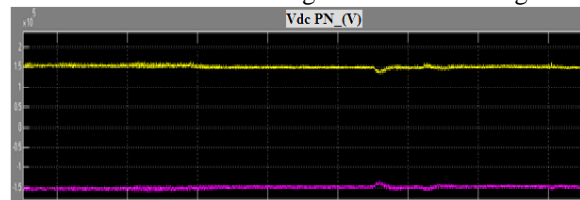

Fig5 .DC Voltage at receiving end

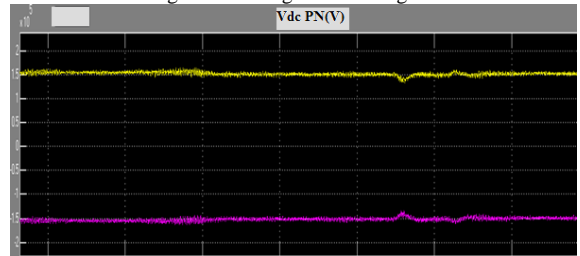

Fig6. DC voltage at sending end

V CONCLUSION

This Paper presents the steady-state performance of AC Transmission System and VSC based HVDC transmission system. The Simulation detail of HVDC system with three levels VSC are discussed and simulation diagram is been studied.

REFERNCES

[1] “Direct current power transmission”, Michael Brahman, ABB.
 [2] “Power system analysis”, I J Nagrath and Kothari, McGraw-Hill Edition.
 [3] Asplundh, Application of HVDC Light to power system enhancement, IEEE Power Engineering Society Winter Meeting., 2000, 4, p. 2498-2503.

[4] Lie Xu , Andersen B. R.; Cartwright P., *Control of VSC transmission systems under unbalanced network conditions*, *Transmission and Distribution Conference and Exposition*, 7-12 Sept, 2003 IEEE PES, 2003, 2, pp. 626-632.

[5] *500 City Center In feed With Voltage Source Converter Based HVDC* By Bjorn Jacobson* Paulo Fischer de Toledo Gunnar Asplundh ABB Power Technologies AB, Latvia, Sweden Groan Isakson, ABB Power Technologies Ltd., India.

[6] C. Du, *The control of VSC-HVDC and its use for large industrial power systems*, submitted to *IEEE Transactions on Power Delivery*.

[7] *MATLAB Simulink*

[8] *Power system analysis* by Waghwa.

[9] *Modeling, Control design and Analysis of VSC based HVDC Transmission Systems*. R. Padiyar and Nagesh prabhu , 2004 international Conference on Power System Technology - POWERCON 2004 Singapore, 21-24 November 2004.

[10] "Comparison tests of fourteen distribution load forecasting methods", *IEEE Transactions on Power Systems*, Vol.PAS-103, No.6, June 1984.

[11] "Short term load forecasting for fast developing utility using knowledge-based expert systems