

# Motorised Car Jack

Mulani S. J.<sup>1</sup>, Koparde J. J.<sup>2</sup>, Suryavanshi A. N.<sup>3</sup>, Yerguntla R. K.<sup>4</sup>, Soni R. K.<sup>5</sup>, Koli V. S.<sup>6</sup>  
 Assistant professor<sup>1</sup> & Graduate student Department of Mechanical Engineering<sup>2,3,4,5,6</sup>  
 AGTIS' Dr. Daulatrao Aher College of Engineering, Karad, Dist. Satara- Maharashtra  
 sarafaraj1978@gmail.com<sup>1</sup>, jitendrakoparde@gmail.com<sup>2</sup>, ajay.suryavanshi3300@gmail.com<sup>3</sup>,  
 yerguntalak@gmail.com<sup>4</sup>, soni.ravi62@gmail.com<sup>5</sup>, vvskk99@gmail.com<sup>6</sup>

*Abstract-An automotive jack is a device used to raise all or part of a vehicle into the air in order to facilitate repairs. Most people are familiar with the basic car jack (manually operated) that is still included as standard equipment with most new cars. These days, a car jack is an important tool to have in our vehicle due to unknown upcoming event such as flat tire in our journey. Even so, people who like to rotate their tires themselves or who may install snow tires before the winter and remove them in the spring need to use a jack to perform the job. Changing a flat tire is not a very pleasant experience. Women have a much lighter skeleton that means, among other things, woman can't pull more forces as well as men and are at greater risk of skeletal injuries. Usually the car purposely tries to get a flat tire at the least opportune moments. On average, 160 injuries are associated with car jacks each year. Injuries have ranged from amputation to fractures and crush injuries. The correct use of jacks can prevent death or injury. Improvement in automotive car jack is really needed to make the tool more efficient, user-friendly, practical to use, changes in industry direction and most importantly high safety features. Further research on car jack is very important. Operating the manual car jack is quite difficult job for pregnant women and old men. The purpose of this project is to encounter these problems. An electric car jack works on current supply from the car battery itself making it easy to operate. Operator only needs to press the button from the controller without working in a bent or squatting position for a long period of time to change the tire. In order to fulfill the needs of present car jack, some improvement must be made.*

**Keywords-** *electric car jack ,flat tires , crush injuries, improvements in jack , high safety features , car battery , easy to operate.*

## I. INTRODUCTION

A mechanical jack is a device which lifts heavy equipment. The most common form is a car jack, floor jack or garage jack which lifts vehicles so that maintenance can be performed. Car jacks usually use mechanical advantage to allow a human to lift a vehicle. More powerful jacks use hydraulic power to provide more lift over greater distances. Mechanical jacks are usually rated for a maximum lifting capacity

(for example, 1.5 tons or 3 tons). Available jack in market is shown in Fig 1.



Figure 1- mechanical toggle jack

Toggle jacks show in Fig 1 are simple mechanisms used to drive large loads for short distances. The power screw design of a common toggle jack reduces the amount of force required by the user to drive the mechanism. A toggle jack is operated simply by turning a small crank that is inserted into one end of the jack.

## II. AUTOMATION OF JACK

We have developed a system which can be used with the toggle jack which makes it automatic in operation. This assembly of parts can be detached easily from the main body of jack which makes the system easier to handle. The parts required are as follows:

### A. The automotive electrical system

The automotive electrical consist of many system and components each having specific purpose. It includes the electric generator, electric battery and various connections. This energy from battery can be utilized to make the jack automatic in operation.

### B. Gearing system

A gear is a rotating machine part having cut teeth which mesh with another toothed part in order to transmit torque, in most cases with teeth on the one gear being of identical shape, and often also with that shape on the other gear. Two or more gears working in tandem are called a transmission and can produce a mechanical advantage through a gear

ratio and thus may be considered a simple machine. Geared devices can change the speed, torque, and direction of a power source. When two gears mesh, and one gear is bigger than the other (even though the size of the teeth must match), a mechanical advantage is produced, with the rotational speeds and the torques of the two gears differing in an inverse relationship.

### C. Modified side block

The side block of the normal toggle jack is required to be modified. A plate is welded to it as shown in fig. 2. The plate has holes made in it for connecting motor part to jack.

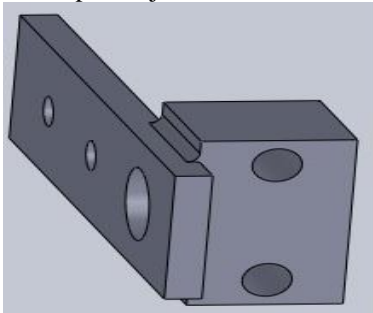

Figure 2. Modified side block

### D. Motor joining system

The DC motor can be connected through a bracket as shown in fig 3. The bracket connects motor on one side while side block on other side. It is connected with the help of Allen bolts and washers so that they can be separated whenever required.

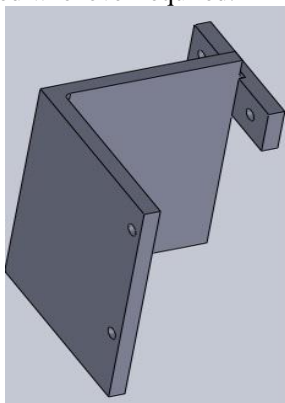

Figure no 3. Bracket

### E. Electric motor

As we are going to use car Battery the motor used should essentially be a 12V DC motor with sufficient torque to overcome the thread friction and to raise the load. We can use wiper or power window motor. For our working model we have used a wiper motor.

### F. A bidirectional DC motor circuit

We can build a DC motor circuit which is capable of spinning forward and in reverse with the flip of a switch, so that the motor can spin forwards or backwards when we want it to. To build a bidirectional DC motor circuit, we need to use a

switch, so that we can go back and forth when we want between forward motion and reverse motion. And the type of switch which is best for this is a Double Throw (DPDT) switch. This will allow us to make connections to the DC motor so that in one direction, the positive voltage is connected to the positive lead of the DC motor and the ground of voltage is connected to the negative lead of the DC motor, and in the other way, the positive voltage is connected to the negative lead of the DC motor and the ground voltage is connected to the positive lead of the motor. This will allow forward and reverse voltage with the flip of a switch.

## III. ASSEMBLY OF PARTS

### A. Motor assembly

The fig. 4 shows motor assembly. It consists of motor, pinion, pinion bush, bracket, Allen bolts and washers. The pinion is connected to motor shaft through bush and Allen bolt also the bracket is connected to motor with the help of two Allen bolts. When the motor is rotated the pinion rotates which in turn rotates the gear on the lead screw.

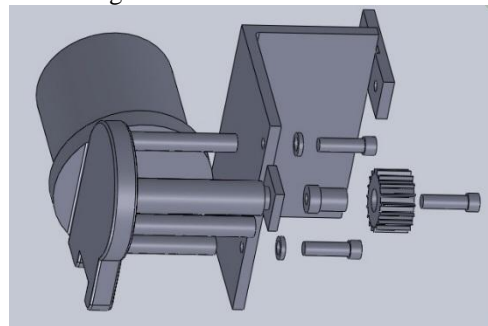

Figure no 4. Motor assembly

### B. Screw assembly

This assembly is shown on fig 5. It connects gear to lead screw through bush and Allen bolt. Also connects side block to motor through bracket. The side block is fitted over the screw. Thus when the gear is rotated the jack gives its up and down motion.

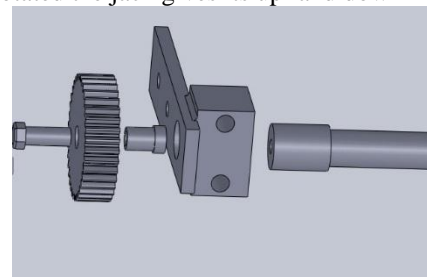

Figure no.5 screw assembly

### C. Overall assembly

It gives idea about all the parts that are required to be added to normal toggle jack to make it automatic. The fig 6. Shows relative positions of different parts and how they are connected to each other.

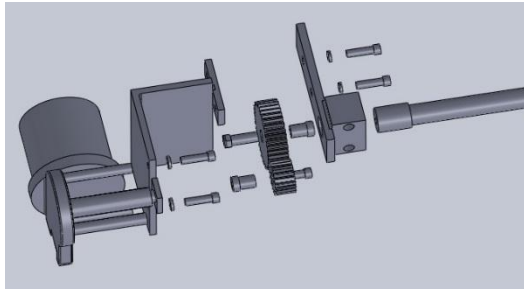

Figure no 6. Overall assembly

#### IV. WORKING OF JACK

With the above stated attachment to the jack the jack becomes automatic in operation. When the motor is connected to battery of car, current flows through motor. A switch is provided for changing the polarity of motor. Hence as the motor rotates the pinion connected to it rotates. The pinion is in mesh with the gear on the lead screw. Because of the gear ratio provided the torque gets multiplied and required torque is applied at the screw. As the screw of jack rotates the jack moves up. The whole assembly is required to be moved in horizontal as well as vertical direction simultaneously. This is achieved by bracket attachment provided between motor and jack. Now when the jack is lifted sufficiently to remove the tire the switch is made off. The tire then can be easily removed. After repairing the tire it is fixed to car. Now with the help of switch the current supply can be reversed so that the jack can be lowered. In this way the jack can be operated easily without much fatigue. The fig no. 7 shows the actual working model that we have manufactured.



Figure no 7. Prootype

#### V. CONCLUSION

The existing design was modified by introduction of an electric motor in the power screw, connecting gear with the pinion, the electric switch connected to the motor and plugged to the automobile 12V battery source to generate power for the prime mover (motor), in order to make load lifting easier. In this modified design, the power screw is rotated through its gear when electrical power flows through it. The main advantages of the modified design over the existing design are that the modified designed motorised jack will save time, be faster and easier to operate and requires less human energy and additional work to operate. There by effectively curb the problems associated with Ergonomics - which is a fundamental concept of design process.

Considering all available car jacks in the market, this prototype can be improved by a few modifications on the features and design. The objectives are to design a car jack that is safe, reliable and able to raise and lower the level, to develop a car jack that is powered by internal car power and automated with button system.

Based on the testing and results from the analysis, it is considered safe to use Jack car work under certain specifications. Furthermore the torque supplied on the system is more than enough to lift a car weight around 1200 kg. There are certain weak points that can be improved based design and balancing of the system.

#### REFERENCES

- [1] Edward Lonnon, "motorized jack", US5085407A, Feb 4, 1992.
- [2] Emil Mickael, "Motor Driven Scissor Jack with Limit Switches", US 6695289B1, Feb 24, 2004.
- [3] Leo F. Carder "Electric Scissor Jack Apparatus", US7988131B1, Aug 2, 2011.
- [4] Noor, M.M., Kadirgama, K., Rahman, M.M., Sani, M.S.M., Rejab, M.R.M., 2008. Development of auto car jack using internal car power. Malaysian Science and Technology Congress, pp. 593-598.
- [5] A. S. Akinwonmi and A. Mohammed "Modification of the Existing Design of a Car Jack"