

AUTOMATIC POTATO CHIPS MAKING MACHINE

YOGITA BHAJIPALE

PRAFUL PATLE

asatu.akshay10@gmail.com

AKSHAY SANGUNWEDHE

DEVENDRA DHAWALE

(Mob.9673820553)

GUIDED BY

Dr. S. K. CHOUDHARY

**Department of Mechanical Engineering, K.D.K college of Engineering,
RTMNU, Nagpur.**

ABSTRACT

Accessories incorporated in efficient performance of automatic chips making machine includes- bin chamber, slicing tool, conveyor belt, drying and frying slot, collecting chamber. Thus, we had been concluded with a machine by appropriate accommodation and arrangement of accessories mentioned above.

Automatic potato chips making machine, enables ample of production with minimum human efforts. Its excellence in production, economy, efficiency, and elegance food-product terms it a boon for **small scale industries**.

INTRODUCTION

India is one of the largest producers of potato. Potato is probably the most popular food item in the Indian diet. It is grown all over the country. Besides being used as a daily food item in various vegetables preparations, potato today increasingly finds use in the form of chips or wafers as snacks food. The potato chips and wafers are popular processed food items that give considerable value addition to potatoes. Rapid urbanisation and improving standards of living have seen manifold increase in the demand of potato chips.

There exists consumer as well as bulk markets. There are some international as well as national brands but majority of the market is penetrated by local manufacturers due to competitive pricing, easy availability at many outlets and very efficient and timely supply as well as replacement. With proper strategy and network, it is possible to penetrate the market.

CONSTRUCTION

Body and chambers allotted to the automatic potato chips making machine is corrosion resistant material. Automatic hopper and cutter block made in stainless steel.

ACCESSORIES

Included Accessories

- 1 of 5 mm chipping block for potato chipper.

Optional Accessories

- Stainless steel mobile stand. Height:975 mm.
- Hopper. Height: 200mm.
- 5 mm chipping block for potato chipper.
- Conveyor belt.
- Frying pan.
- Collection pan.

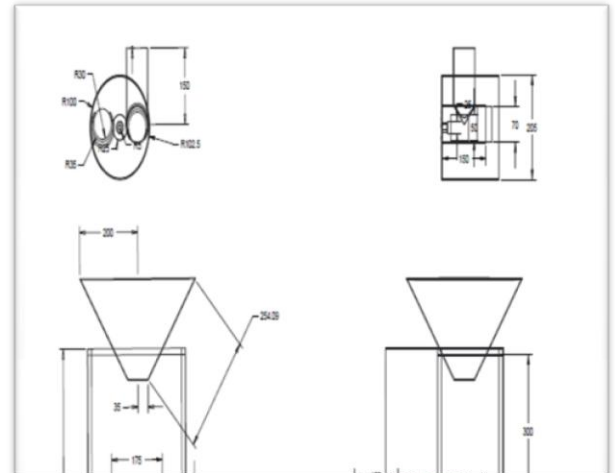

ELECTRIC

Supply voltage:
601091 (RC14CG): 230 V/ 1N ph/ 50 Hz.

CAPACITY

Performance (up to): 10-12 kg/hour.

CONCLUSION

Thus we conclude that the model report is to facilitate the entrepreneurs in understanding the importance of setting up unit of potato chips. This model will

KEY INFORMATION

External dimensions, Height 975 mm
External dimensions, Width 435 mm
External dimensions, Depth 600 mm
Shipping weight: 35 kg
Potatoes slicing capacity: 40 kg
Chip cutting capacity: 40 kg

serve as guidance to the entrepreneurs on starting up such a new project and basic technical knowledge for setting up such a facility. Efficiency of this model enhances

its utilization as industrial as well as

domestic household purpose.

REFERENCES

- [1] CEP November 2013, www.aiche.org/cep PP 25-32, Copyright ©2013 American Institute of Chemical Engineers (AIChE)
- [2] Continental J. Engineering Sciences 2: 49 - 57, 2007
©Wilolud Online Journals, 2007.
- [3] IOSR Journal Of Environmental Science, Toxicology And Food Technology (IOSR-JESTFT) e-ISSN: 2319-2402,p- ISSN: 2319-2399. Volume 7, Issu2 (Nov. - Dec. 2013), PP 12-16 www.iosrjournals.org
- [4] United States Patent Sprecher et al. Patent Number:5,392,698 Date of Patent: Feb. 28, 1995
- [5] Google patents-send feedback data provided by IFI Claims patent Services
- [6] 7th InternationalConferenceonAppliedElectrostatics(ICAES-2012) IOP Publishing Journal ofPhysics:ConferenceSeries 418 (2013) 012144
doi:10.1088/1742-6596/418/1/012144
- [7]International Journal of Advancements in Research & Technology, Volume3, Issue 7, July-2014 ISSN 2278-7763
- [8] www.fryer sogo.com
-

