

Solar Powered Smart Irrigation System with GPRS

Ms. Pranali Dhanole^{#1}, Ms. Pranali Wagh^{#2}, Ms. Priti Thakare^{#3}, Ms. Purna Tembhurnikar^{#4}, Ms. Priyanka Ukey^{#5}, Ms. Priyanka Ghaiwat^{#6}, Ms. Ravina Raut^{#7}

[#]Electrical Engineering, RTMNU

Smt. Rajshree Mulak College of Engineering for Women, Nandanvan, Great Nag Road, Nagpur, India

¹pranalidhanole@gmail.com

²pranaliwagh31@gmail.com

³preeti1823@gmail.com

⁴pikutembhurnikar@gmail.com

⁵priyankaukey80@gmail.com

⁶priyankaghaiwat95@gmail.com

⁷rwraut24@gmail.com

Abstract— Cost effective solar power can be the answer for all our energy needs. This system will consist of solar powered water pump along with an automatic water flow control using a moisture sensor, water level sensor and timer. The status of system will be notified to the farmers by using Global Packet Radio Service (GPRS). It is the proposed solution for the present energy. In today's world, both water and electricity are costly and scarce in supply. The proposed model of solar powered Irrigation System is an error free, environment friendly, environment synchronized, and cost effective. Solar water pumps can supply water to locations which are beyond the reach of power lines. Commonly, such places rely on human or animal power or on diesel engines for their water supply or where the frequent power cuts are observed and the power when available is not pure and enough (Indian Conditions in Rural). Solar power is also reliable alternative which is being used in a wide spread of the ever so developing technology in the world.

Keywords—Solar panel, soil moisture sensor, microcontroller, water level sensor, GPRS (Global Packet Radio Service).

I. INTRODUCTION

The process of supplying water for crops is known as irrigation. In India, agriculture plays a very important role to development of country as our economy mainly based on it. India ranks second worldwide in farm output. About 2/3rd cultivated land in India is dependent on Monsoon. Irrigation helps to improve food security, reduce dependence on monsoon, improve agricultural productivity and

create rural job opportunities. Almost 70% of India's population depends on agriculture either directly or indirectly. Irrigation, therefore, is essential for good crop yield. Most electrical consumption in this sector goes towards operating pump sets for irrigation. Traditionally, irrigation is done manually where farmers pulls out water from wells or canals by him or using cattle and carries to the farming field. Main advantage of this system is that it is cheap but efficiency is poor and is time consuming. Some examples of traditional system are pulley system, lever system, chain pump and Deli. Among this pump system is more common and widely used.

In current scenario, electrical energy and fossil fuel are used for pumping system. Since fossil fuels commence to annihilate besides its increasing of prices and hazards to environment alternative energy seeking efforts has become inevitable also in agricultural sector. In 2006–7, India's agricultural sector accounted for 22% of the total electricity consumption, up from 10% in the 1970s. There are about 21 million irrigation pump sets in India, of which about 9 million are run on diesel and the rest are grid-based [7].

Solar energy is the most abundant source of energy in the world. Solar power is not only an answer to today's energy crisis but also an environment friendly form of energy. Photovoltaic

generation is an efficient approach for using the solar energy. The cost of solar panels has been constantly decreasing which encourages its usage in various sectors. One of the applications of this technology is used in irrigation systems for farming. Solar powered irrigation system can be a suitable alternative for farmers in the present state of energy crisis in India. This is a green way for energy production which provides free energy once an initial investment is made.

II. OBJECTIVE

1. To develop sensor base irrigation system based on soil moisture and water level.
2. To avoid wastage of water by using timer based feature.
3. To monitor the pumping system from a place far away from irrigation field.

III. PROPOSED METHODOLOGY

Solar panel produces power in order to drive the whole system. The generated DC output from solar panel is fed to the MPPT. The constant voltage obtained from MPPT is stored in battery. The inverter produces required AC output. This AC supply is supplied to the motor if and only if it is healthy. This is done by protection present just before motor. The water level sensor senses the water level as low and high. If the water level is low then water level sensor turns OFF the motor by sending signal to the microcontroller. The timer is set with a particular time for which the motor is to be operated. If the timer reaches to zero it turns off the motor. Moisture sensor senses the water content of soil and compares it with a predefined value. If water content reaches up to predefined value it turns off the motor by using microcontroller.

The priority of water level sensor will be highest. If water level in well is low, the motor does not operate even if timer is on or there is less moisture in soil. Timer has second highest priority. On or off operation of timer takes place by considering predefined time and by ignoring the signal from moisture sensor. The proposed system has a unique

feature of sending notification about the status of pump to the farmers. This is done by GPRS system. This system is able to give brief information about the reason of ON or OFF condition of motor. This is done with the help of GPRS module. The status of motor is also available on the LCD display provided near motor. This will provide instant idea about the motor to the farmer.

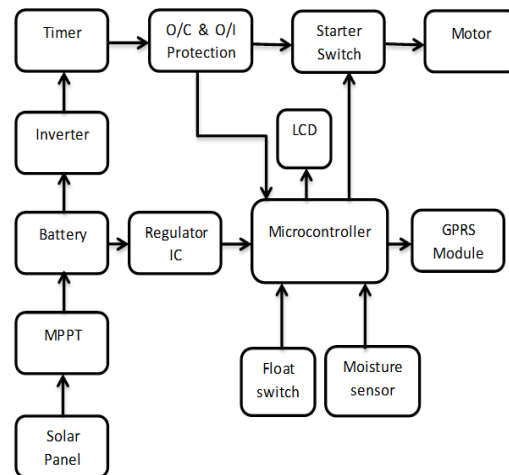

Fig. Block diagram of solar powered smart irrigation system with GPRS

Following are the major components from which the system is fabricated.

1. Solar Panel
2. MPPT
3. Battery
4. Inverter
5. Starter switch
6. Pump
7. Timer
8. Moisture Sensor
9. Water Level Sensor
10. Regulator IC
11. Microcontroller
12. LCD
13. GPRS Module.

A. Irrigation system

This is the part of the system which involves the main irrigation process, which is not having any controlling mechanism. The solar panel generates DC output by absorbing solar radiations. This Dc power is fed to the MPPT (Maximum power point tracking system). The main purpose of MPPT is to maintain the constant power at its output because supply to the battery should be constant. Thus MPPT bucks or boost the supply according to the requirements. The MPPT circuit consist of inductor, capacitor and MOSFET. Output from MPPT is given to Lead- acid battery. During day time, the motor will operate on power obtained from solar panel. In this duration battery will continue to charge. When sunlight is not available battery will supply the motor.

Battery supplies the DC power to the inverter. The inverter is of PWM type which gives AC power at its output terminal. In order to protect the circuit from over current and over voltage single phase protection is provided just before relay switch. Relay switch is the combination of transistor and relay. This switch will not operate until and unless it do not get signal from microcontroller. The motor use can be single phase or three phases according to requirement. The rating of all the components mentioned above can change according to the area to be irrigated, size of motor and solar radiations available in particular area.

B. Controlling system

Microcontroller performs all the controlling actions. It works on 5 volt DC supply. Regulator IC 7805 connected between battery and microcontroller provides 5 volt DC at its output. Microcontroller gets signal from moisture sensor, water level sensor and timer. This three act as an input to the microcontroller. The relay switch is also connected to the microcontroller so that whenever microcontroller gets signal from any of the three inputs it should turn OFF or ON the motor. LCD is interface with microcontroller. The status of motor is displayed on LCD. The system status is notified to the farmer with the help of GPRS module. This can be done with the help of SMS or android application.

The various conditions during operation are tabulated bellow.

Water Level	Moisture Level	Motor Status	Message Displayed
High	Dry	ON	Irrigation is ON
High	Wet	OFF	Irrigation is OFF
Low	Dry	OFF	Water level low MOTOR OFF
Low	Wet	OFF	Water level low MOTOR OFF

The sequence of priority is water level sensor, timer and moisture sensor. There are two modes in timer manual and automatic. Required time for irrigation can be set by using keypad of timer. As soon as the set time runs out, motor will turn OFF.

IV. ADVANTAGES

The main advantages of the system are as follows

- Water level sensor protects the motor from damaging when there is no water in well. This feature reduces maintenance cost of the system.
- By setting required time of irrigation the wastage of water can be reduce.
- Excess irrigation can be avoided by using soil moisture sensor. This system provides water according to crop water requirement.
- The system uses solar energy; therefore it can be used in the areas where electricity is not available
- As the system uses renewable energy, it does not produce waste product such as carbon dioxide. Hence it is environment friendly.
- This system avoids irrigation at wrong time and does improve crop performance and prevents salinity of agricultural land.
- Automatic irrigation system reduces human error in adjusting soil moisture level.

- This system reduces human efforts. The automated irrigation system detects the soil moisture condition and performs automatically according to predefined moisture condition.
- This system gives immediate idea about status of the motor. The status becomes available on farmers mobile. Thus monitoring the system from distant place becomes possible.

V. APPLICATION

The main application of this system is for irrigation purpose. This system has great importance in greenhouses where highly accurate soil moisture control is required. This system can be a good solution for the areas where v electricity is not available. This system is beneficial to both government and farmer because it is the solution for present water shortage and energy crisis.

VI. CONCLUSION

This system is design considering low cost, reliability, alternate source of electric power and automatic control. As the system is automatic it always insures sufficient level of water in the soil. The proposed model can be suitable to overcome the scarcity of electricity and ease the irrigation system. Further this model can be modified to have advance security arrangement so that any other person except the farmer should not able to operate it.

REFERENCES

- [1] Prof. Rupali S. Sawant, Shreejit Gubre, Swati Pillai, Monica Jain, "solar panel based automatic plant irrigation system", international journal of innovative science, engineering and technology, vol. 2, issue: 03 March 2016 .
- [2] <http://harmnest.com/forum/farmerquipment/5hp-4hp/solar-borewell-water-pumping-hosui/>
- [3] Naveed Alam, Adil Naseem, "solar powered auto irrigation system", issue: 2014.
- [4] Prof. D. Babu Rajendra Prasad, Sunil. N, Drupad. V. , Madhu.CN, Yashavantha. BK, "GSM Based Smart Agriculture System with Auto Solar Tracking", vol. 03, issue: june 2015
- [5] S. Harishankar, R. Sathish Kumar, Sudharsan K.P, U. Vignesh and T.Viveknath, "solar powered smart irrigation system", vol. 04, issue: 2015
- [6] Sanjukumar, R.V.Krishnaiah, " Advance Technique for Soil Moisture Content Based Automatic Motor Pumping for Agriculture Land Purpose", International Journal of VLSI and Embedded Systems-IJVES, Vol. 04, issue: September 2013
- [7] Amit Desai,"Application of solar PV based pumping for irrigation", 2012 december